

# **PROKIT EP 200** **Safety System**

Assembly Instructions for Standard Configuration

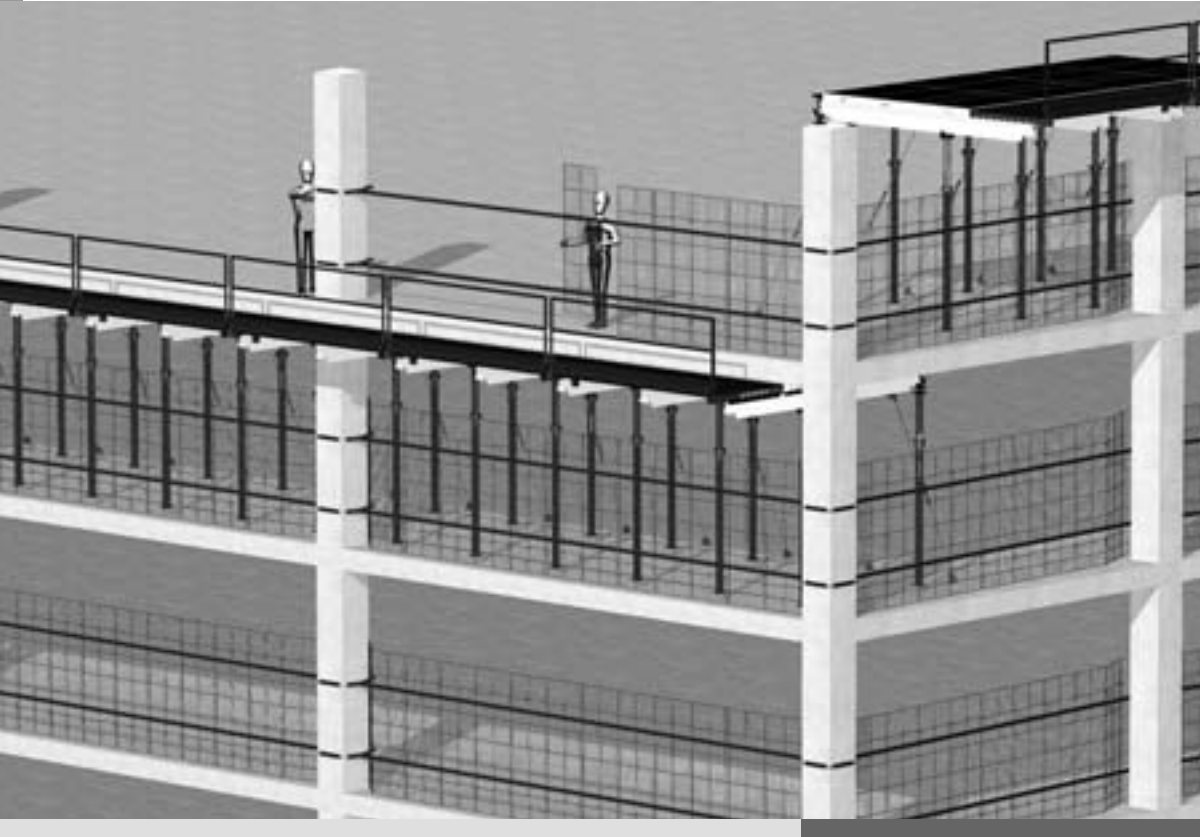



# Content

## Introduction

Overview of main components	1
Standard Configuration	2
Intended Use	2
Safety Instructions	3
General	3
Checks and Inspections	4
Classification	5

## Standard Configuration

A1	Logistics	
	Storage and Transportation	6
	Maintenance and Cleaning	7
A2	Assembly of Fold Mesh	
	Intermediate supports	8
	Intermediate walls	12
A3	Extensions	
	Third Tension Belt position	14

## Components

Components	16
------------	----

**Key**



Safety Instructions



Note



Visual Check



Tip

# Introduction

## Overview of main components

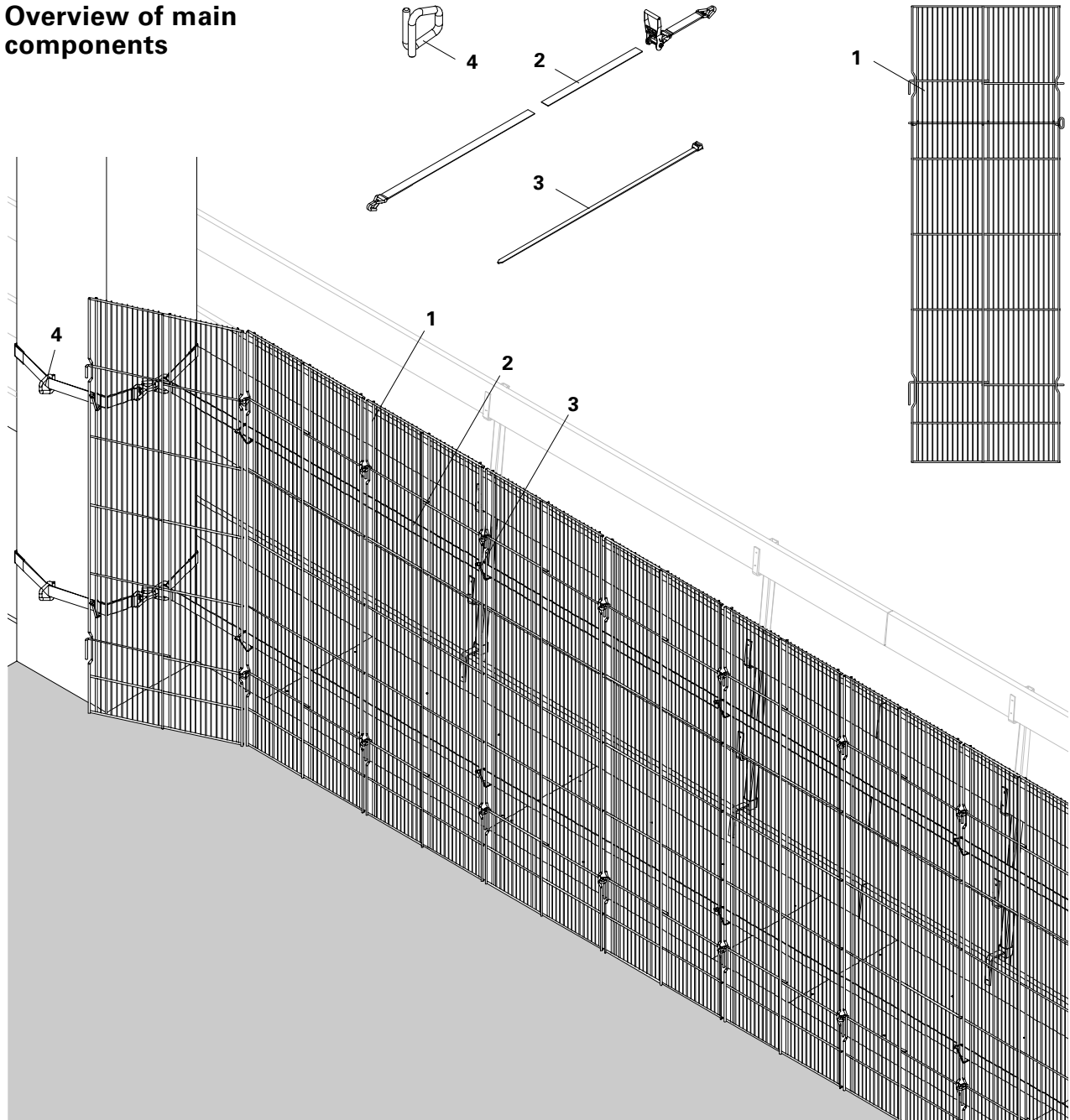

- 1 Fold Mesh PFR
- 2 Tension Belt PTB12, two-piece
- 3 Cable Tie PCT
- 4 Eyelet PE

# Introduction

## Standard Configuration

### General

Primarily, the PROKIT EP 200 provides protection against falling for personnel working in skeleton structures. PROKIT EP 200 also secures extensive areas of open building edges in order to prevent tools and materials from falling off. With only two main components and accessories, numerous situations can be secured. Columns and bulkhead walls serve as fixing points for the tension belts.

### System Dimensions

Fold Mesh PFR: Height: 200 cm  
 Width: 66 cm  
 3 Mesh = 2.00 m  
 Tension Belt PTB: 12 m

### Technical Data

- verification of load capacity according to EN 13374, Class A.

---

## Intended Use

1. PERI products have been designed as technical work equipment for exclusive use in the industrial and commercial sectors by suitably trained personnel.
2. These assembly instructions serve as a basis for the building-related risk assessment and instructions for the provision and use of the system by the contractor (user). However, they do not replace these.
3. Only PERI original components may be used. The use of other products and spare parts represents a misapplication with associated safety risks.
4. The components are to be inspected before each use to ensure that they are in perfect condition and function correctly.

5. Changes to PERI components are not permitted and represent a misapplication with associated safety risks.
6. Safety instructions and permissible loads must be observed at all times.
7. Components provided by the contractor must conform with the characteristics required in these assembly instructions as well as all valid construction guidelines and standards.

In particular, the following apply if nothing else is specified:

- timber components: Strength Class C24 for Solid Wood EN 338.
- scaffold tubes: galvanised steel tubing with minimum dimensions Ø 48.3 x 3.2 mm according to EN 12811-1:2003 4.2.1.2.

- scaffold tube couplings according to EN 74.
- 8. Deviations from the standard configuration may only be carried out after a separate risk assessment has been completed by the contractor (user). On this basis, appropriate measures for the working safety and stability are to be implemented.



# Introduction

## Safety Instructions

### General

1. Deviations from the standard configuration and/or intended use present a potential safety risk.
2. All country-specific laws, standards and other safety regulations are to be taken into account whenever our products are used.
3. During unfavourable weather conditions, suitable precautions and measures are to be taken in order to ensure both working safety and stability.
4. The contractor (user) must ensure the stability throughout all phases of construction. He must ensure and verify that all loads which occur are safely transferred.
5. The contractor (user) has to provide safe working areas for site personnel which are to be reached through the provision of safe access ways. Areas of risk must be cordoned off and clearly marked. Hatches and openings on accessible working areas must be kept closed during working operations.
6. For better comprehensibility, detailed drawings are partly incomplete. The safety installations which have possibly not been featured in these detailed drawings must nevertheless be available.

### Storage and Transportation

1. Do not drop the components.
2. Store and transport components ensuring that no unintentional change in their position is possible. Detach lifting gear from the lowered units only if these are in a stable position and no unintentional change is possible.
3. When moving the components, make sure they are lifted and set down so that any unintentional tilting over, falling apart, sliding or rolling away are avoided.
4. Use only suitable load-carrying equipment to move the components as well as the designated load-bearing points.
5. During the lifting and moving procedure, ensure all loose parts are removed or secured.
6. During the moving procedure, always use a guide rope.
7. Move components on clean, flat and sufficiently load-bearing surfaces only.

### System Specific

1. Install anchoring and safety barriers before dismantling the working scaffold positioned below.
2. Columns and walls must have a sufficiently high concrete strength. Tension Belts are to be tensioned with approx. 5 kN.
3. Safety barriers are to be dismantled only if the facade is closed.

### Tension Belt PTB 12

1. Tension Belt PTB 12 is to be checked during use and, if necessary, re-tensioned.
2. Do not place Tension Belt PTB 12 over sharp edges or cracked surfaces without providing suitable protection. Use edge protection.
3. Protect Tension Belt PTB 12 against heat and chemical influences.
4. Do not twist the Tension Belt PTB 12 and keep it free of knots.
5. Do not use the Tension Belt PTB 12 for pulling or lifting loads.
6. Do not set down any loads on the Tension Belt PTB 12.
7. Ensure that the ratchet is not positioned on an edge when belt is tensioned.
8. At least 1.5 winds of the belt on the ratchet, maximum 3 winds.
9. Do not load belt hooks on the tips.

---

## General

### Additional PERI product information

- EP 200 brochure
- Instructions for Use for pallets and stacking devices
- Anchor Bolt PERI 14x150 data sheet

The structures shown in these assembly instructions are examples and feature only one component size. They are accordingly valid for all component sizes contained in the standard configuration.

# Introduction

## Checks and Inspections

### 1. General

According to §3 Paragraph 3 of the Industrial Safety Regulations, the contractor is responsible for determining the type, range and deadlines regarding the required checks to be carried out on the work equipment. As a result of these checks, any safety-related defects are to be systematically identified and remedied.

### 2. Purpose

Due to the check carried out before the initial operations as well as regularly recurring inspections of the load-carrying equipment, it can be ensured that operational and functional reliability is guaranteed.

### 3. Responsibility

The contractor must ensure that work equipment can only be put into service if it has been inspected by a technical expert and all defects have been addressed and any non-functioning equipment has been replaced.

### 4. Inspection

#### 4.1 Instigating the safety inspection

The contractor arranges for an inspection to take place before initial operations of the work equipment begin, which is to be carried out by a suitably qualified person.

### 4.2 Implementing the inspection

The inspection includes a visual and functional check.

#### Visual Check

- deformation and wear of all parts
- mechanical damage
- availability of all components
- damage due to corrosion
- cracks on welding seams and individual components

#### Functional Check

- free and easy movement of moving parts
- locking system works correctly
- safety pawls and safety hooks engage
- eyes or shackles for fastening purposes are usable

Implementation of anything beyond the usual scope of inspection is subject to the discretion of the competent person and can extend to additional checks.

### 4.3 Measures

If any defects are found during the safety inspection, they must be rectified according to specifications provided by the technical expert. Subsequently, a new inspection is to be carried out.

**Only PERI original components may be used as spare parts.**

### Replacing the Tension Belt PTB 12

Tension belts are to be replaced if:

- the belt label is unreadable or missing.
- the belt has cuts, holes or abrasion marks.
- the belt shows signs of deformations.
- the hooks or ratchet are twisted or strongly corroded.
- the hook aperture is open by more than 10%.



# Introduction

## Identification of the Tension Belt PTB 12

### Belt label



**Anti-fall protection!**  
**If the belt label is missing or unreadable, do not use the Tension Belt PTB 12!**  
**Use a new tension belt!**

<b>UTX<sup>®</sup></b> 100% PES <small>Unitex Safety - Equipment(KunShan) Co., Ltd.</small>	
100% POLYESTER	
<b>Shf 50 daN</b>	
<b>Stf 400 daN</b>	
 <b>LC 2500 daN</b>	
 <b>LC 5000 daN</b>	
Niet hijsen-alleen sjoeren Ne pas lever- Seulement arrmimer No lifting-only lashing Nicht heben-Nur zurren	
<b>PU3 EN 12195-2</b> <small>Rek / Dehnung/Elongation/Allongement&lt;7%</small> <b>Model: UTX50AER/2</b> Serie Nr.: Code. <b>Jaar/Jahr/Year/Ans/ 20</b>	
<b>(LGF) 0.4 mtr.</b>	

<b>UTX<sup>®</sup></b> 100% PES <small>Unitex Safety - Equipment(KunShan) Co., Ltd.</small>	
100% POLYESTER	
<b>Shf 50 daN</b>	
<b>Stf 400 daN</b>	
 <b>LC 2500 daN</b>	
 <b>LC 5000 daN</b>	
Niet hijsen-alleen sjoeren Ne pas lever- Seulement arrmimer No lifting-only lashing Nicht heben-Nur zurren	
<b>PU3 EN 12195-2</b> <small>Rek / Dehnung/Elongation/Allongement&lt;7%</small> <b>Model: UTX50AER/2</b> Serie Nr.: Code. <b>Jaar/Jahr/Year/Ans/ 20</b>	
<b>(LGL) 11.6 mtr.</b>	

# A1 Logistics

## Storage



Please adhere to the PERI Instructions for Use for Pallets and Stacking Devices as well as Pallet Lifting Trolley!

Manually-created transport units must be correctly stacked and secured! Pallets and stacked items are to be protected against the effects of the weather, e.g. secured against lifting by means of tension belts!

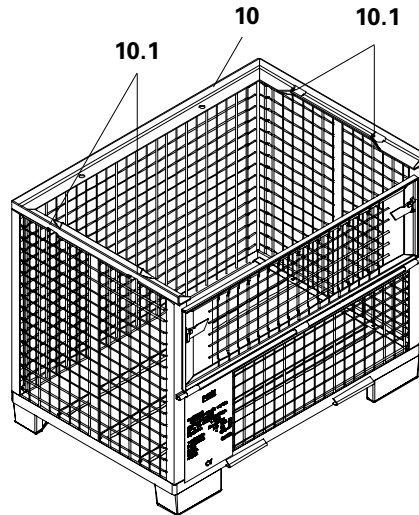

Fig. A1.01

**Crate Pallet 80 x 120**

**Permissible lifting capacity: 1.5 t**

**Length of 4-sling lifting gear:**

**min. 3.0 m**

### Stacking height

3 crate pallets (10) on top of each other.

(Fig. A1.01)

## Stacking

e.g. Pallet RP 80 x 120

Fold Mesh PFR: max. 45

(Fig. A1.02)

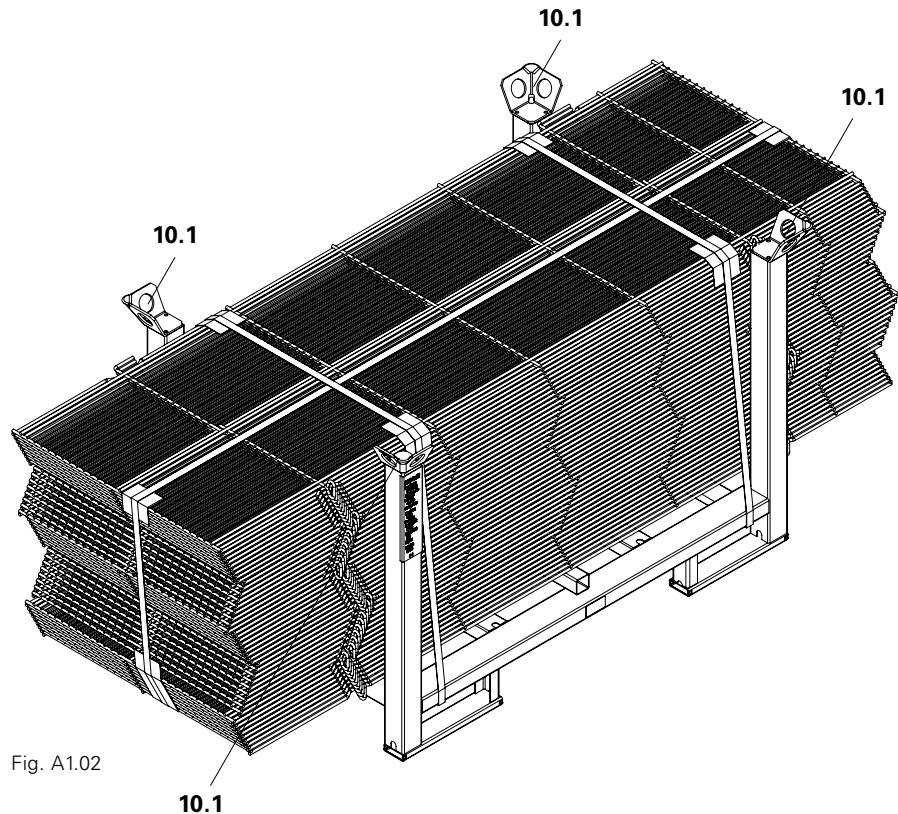

Fig. A1.02

## Transportation



**Always attach the 4-sling lifting gear to the four designated lifting points (10.1)!**

(Fig. A1.01 + A1.02)



When loading onto trucks, current regulations are to be observed. Be careful not to damage the Fold Mesh when securing.

# A1 Logistics

## Maintenance and Cleaning

**In order to maintain the value and operational readiness of the safety system over a long period of time, ensure that individual components are carefully handled at all times.**

### Maintenance tips

1. For damage-free transportation, suitable PERI pallets are available.
2. For temporary storage, support timbers are to be used.
3. Due to the powder coating, cleaning requirements are kept to a minimum.

## Tension Belt PTB 12

- Ensure that Tension Belts PTB 12 are stored tidily and in dry conditions.
- Tension Belts PTB 12 can be cleaned with cold water without any cleaning agent and leave to dry in the air.
- Moving parts of the ratchet are to be regularly oiled.

# A2 Assembly of Fold Mesh

## Intermediate supports

Clear width < 8.0 m.

For extensive securing of the building edges. The covering may also be used as material protection. As a dust shield, an additional dust protection cover must be attached.

### Required components:

<b>1</b> Fold Mesh PFR	1x
<b>2.1</b> Tension Belt PTB 12	1x
<b>2.2</b> Lashing strap with fixed end	1x
<b>3</b> Cable Tie PCT	
<b>4</b> Eyelet PE	4x
<b>5</b> Edge protection hose	*x

\* depending on the support cross-sections: up to 4x.

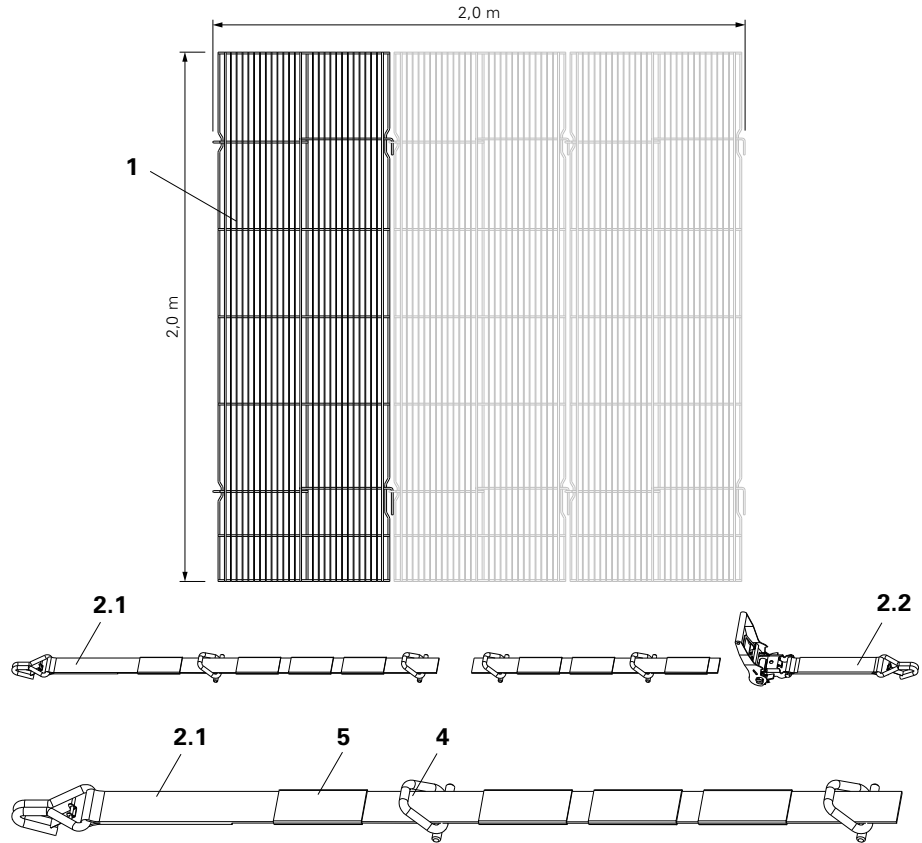

Fig. A2.01



### Risk of falling!

Assembly is to take place with site personnel positioned on a secure working and safety scaffold or with the use of personal protective equipment!

### Sub-construction -

#### First tension belt position - starter: prepare Tension Belt PTB

Alternating on Tension Belt PTB (2.1): 1 x edge protection (5), 1 x Eyelet PE (4), 3 x edge protection and 1 x Eyelet PE as direction change.

(Fig. A2.01)

#### First support: mount Tension Belt PTB

1. Place Tension Belt PTB with edge protection around the support at knee high, and attach hook to Eyelet PE.
2. Align and tension on next support. (Fig. A2.02 + A2.02a + A2.02b)

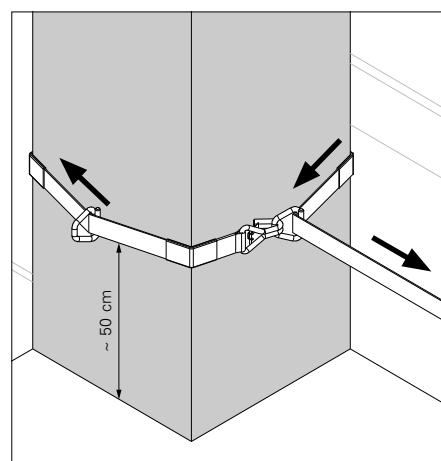

Fig. A2.02

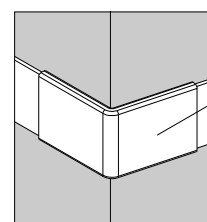

Fig. A2.02a

#### Top view

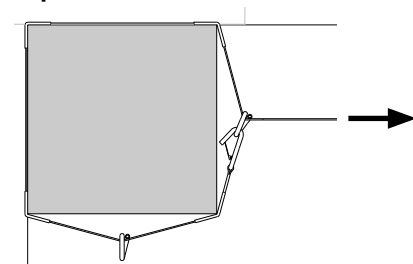

Fig. A2.02b

# A2 Assembly of Fold Mesh

## Second support: mount Tension Belt PTB

1. Alternating on end of belt: 1 x Eyelet PE (4) as direction change, 2 x edge protection (5), 1 x Eyelet PE and 1 x edge protection. (Fig. A2.03)
2. Attach lashing strap (2.2) to first Eyelet PE.
3. Insert end of belt into the ratchet and tension. (Fig. A2.04 + A2.04a, A2.04b)
4. Attach next Tension Belt PTB to Eyelet PE and tension on next support. (Fig. A2.05)

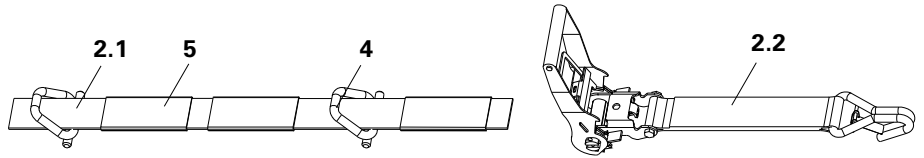
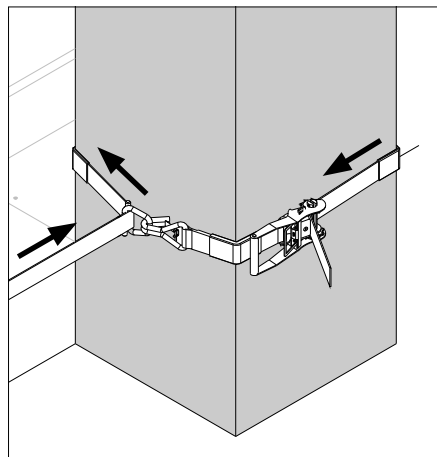

Fig. A2.03



Top view

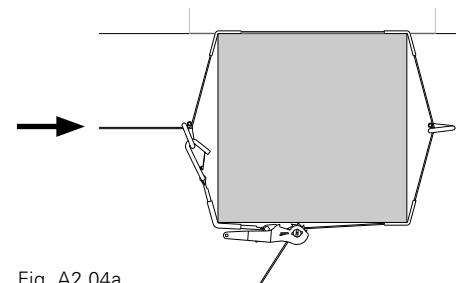

Fig. A2.04a

Fig. A2.04



**Functionality is limited!**  
**Ensure that tension belt remains free of knots and do not connect mechanically!**

## Third and additional supports: mount Tension Belt PTB

1. Alternating on end of belt: 1 x Eyelet PE, 2 x edge protection, 1 x eyelet PE, 1 x edge protection.
2. Attach lashing strap to first Eyelet PE.
3. Insert end of belt into the ratchet and tension. (Fig. A2.03 + A2.04)

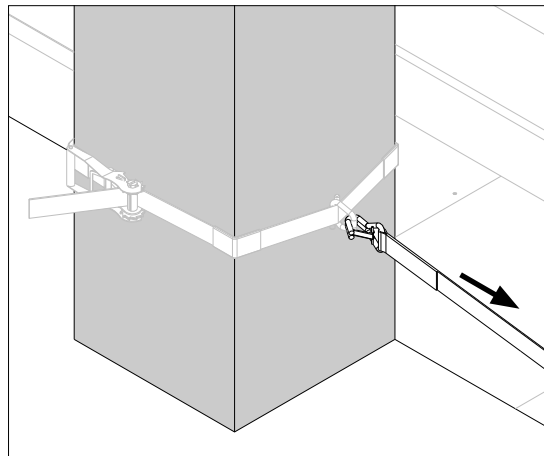

Fig. A2.05

## Anti-fall protection

- work and safety scaffolding (Fig. A2.06a)
- with personal protection equipment (PPE). (Fig. A2.06b)

Fig. A2.06a

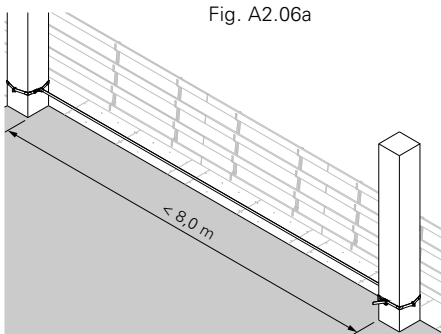
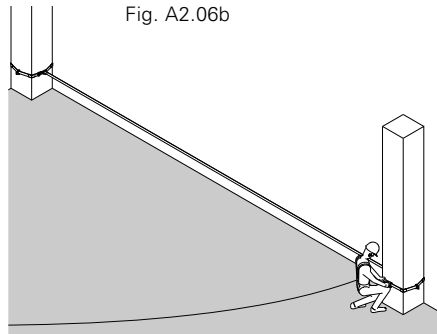

Fig. A2.06b



# A2 Assembly of Fold Mesh



**Risk of falling!**  
**Assembly is to take place with site personnel positioned on a secure working and safety scaffold or with the use of personal protective equipment (PSA)!**

**Sub-construction**  
**Second Tension Belt position**  
 Spacing approx. 1.0 m.  
 (Fig. A2.07 + A2.07a)

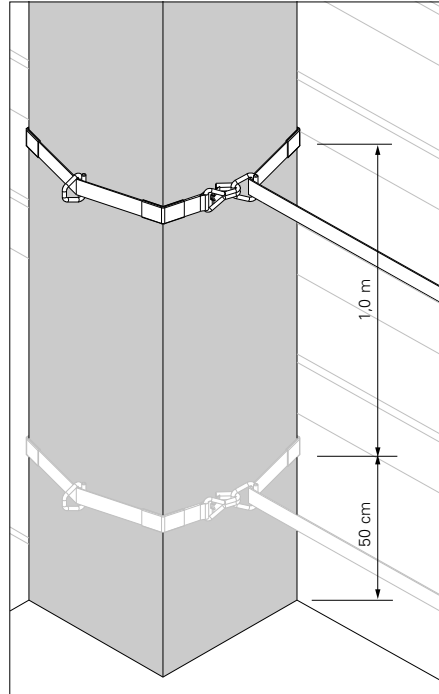

Fig. A2.07

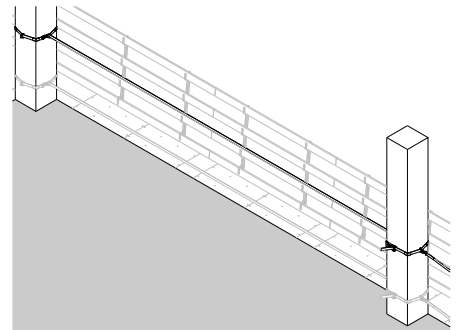

Fig. A2.07a

## Mount Fold Mesh PFR

1. Lean Fold Mesh PFR (1) against the tension belt and fix by means of Cable Ties PCT (3).  
 (Fig. A2.08 + A2.08a)

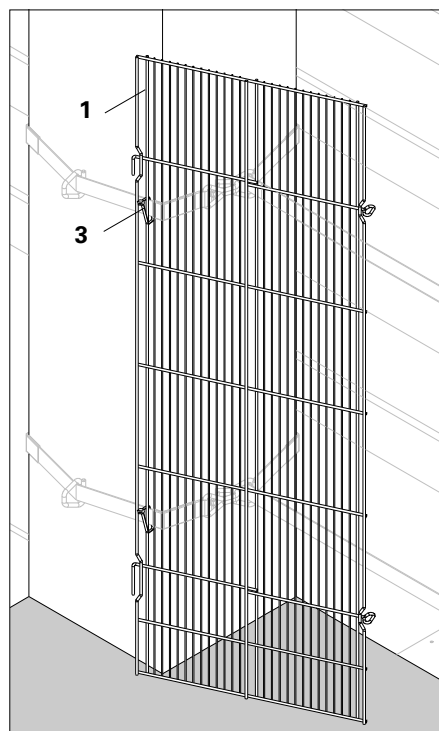

Fig. A2.08

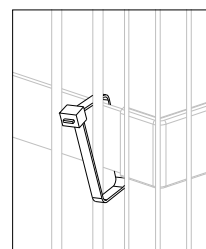

Fig. A2.08a

# A2 Assembly of Fold Mesh

### Mount Fold Mesh

2. Attach second Fold Mesh PFR to first Fold Mesh PFR and fix by means of Cable Ties PCT.

3. Attach additional Fold Mesh PFR and fix every second joint with Cable Ties PCT.

(Fig. A2.09 + A2.09a – 09c)

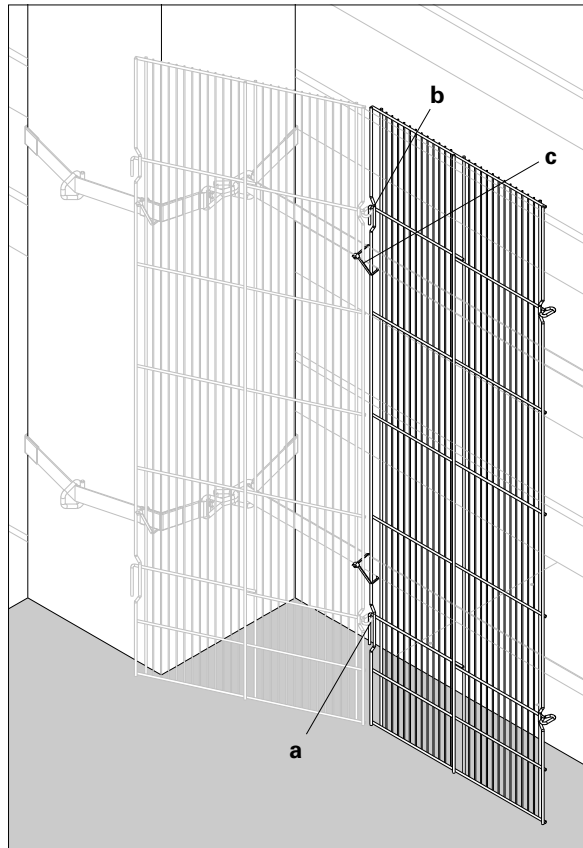

Fig. A2.09

### Top view

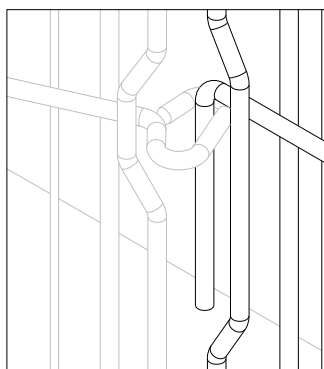
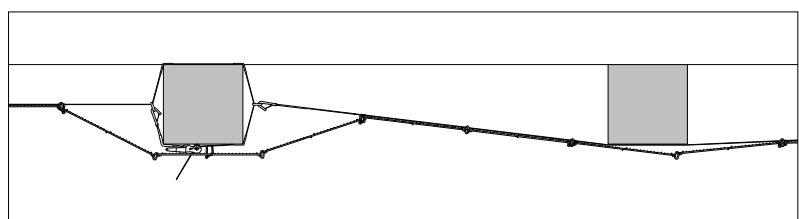

Fig. A2.09a

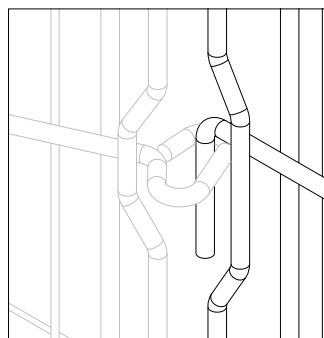

Fig. A2.09b

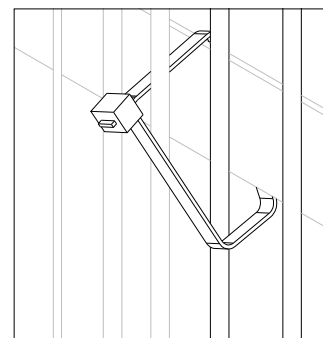

Fig. A2.09c

# A2 Assembly of Fold Mesh

## Intermediate walls

Clear width < 8.0 m.

For tensioning the tension belts between walls, wall fixings are used.

### Required components:

<b>1</b>	Fold Mesh PFR	1x
<b>2.1</b>	Tension Belt PTB 12	1x
<b>2.2</b>	Lashing strap with fixed end	1x
<b>3</b>	Cable Tie PCT	
<b>6</b>	Wall Fixing PWF	2x
<b>7</b>	Anchor Bolt PERI 14x150	2x



### Risk of falling!

**Assembly is to take place with site personnel positioned on a secure working and safety scaffold or with the use of personal protective equipment (PPE)!**

### Assembly

1. Fix Wall Fixing PWF (6) with anchor bolts (7).
2. Attach Tension Belt PTB (2.1) to Wall Fixing PWF. (Fig. A2.10a)
3. Attach lashing strap (2.2) to Wall Fixing PWF. (Fig. A2.10b)
4. Insert end of belt into the ratchet and tension according to length.
5. Lean Fold Mesh PFR (1) against the tension belt and fix by means of Cable Ties PCT (3). (Fig. A2.10)

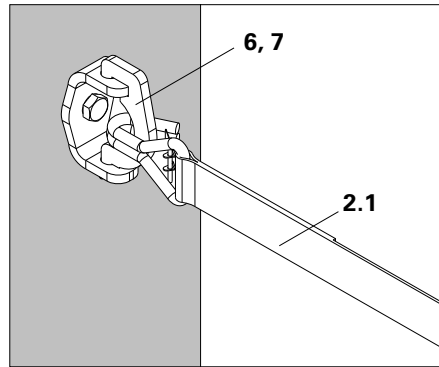

Fig. A2.10a

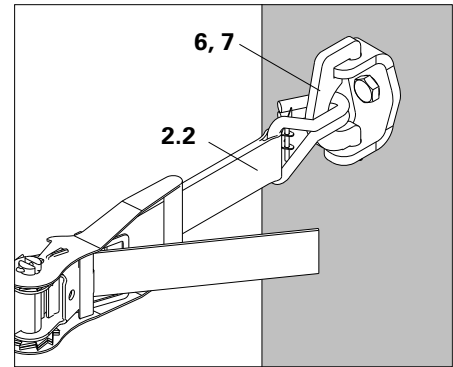

Fig. A2.10b

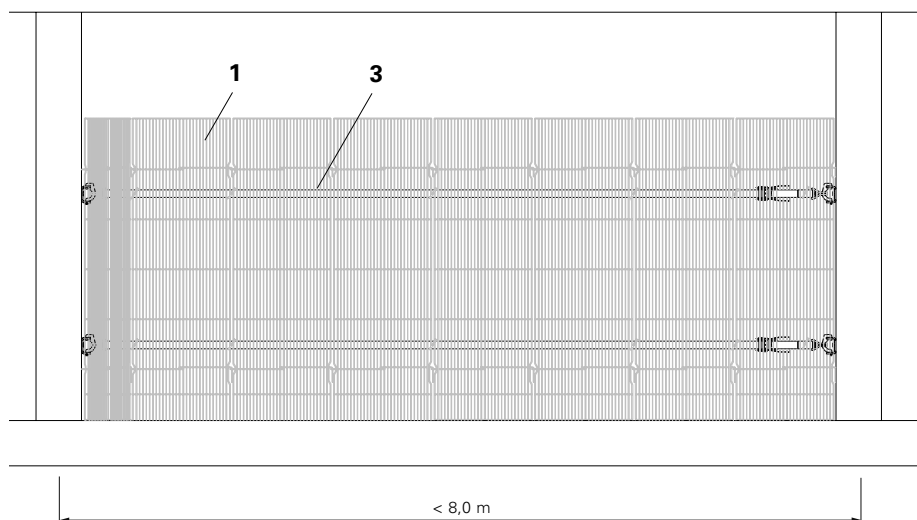

Fig. A2.10



# A2 Assembly of Fold Mesh

## Edge areas

1. On a wall side, lean Fold Mesh PFR against the wall and mount additional Fold Mesh PFR. (Fig. A2.11a)
2. Lean last Fold Mesh PFR against the other wall side and fix overlapping by means of Cable Ties PCT. (Fig. A2.11b + A2.11c)

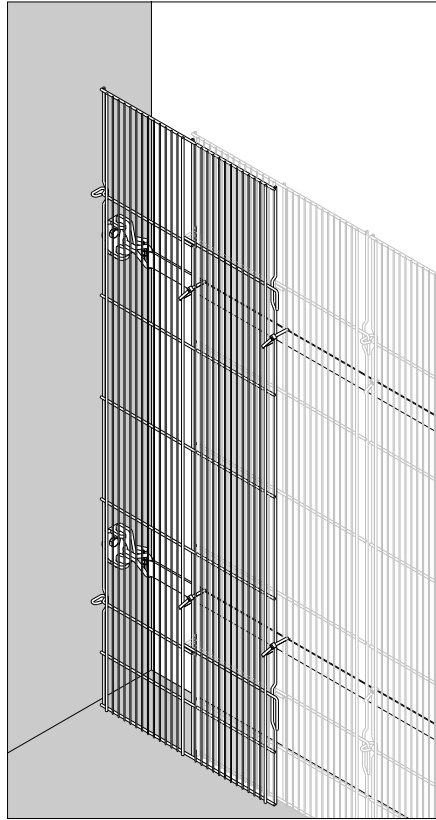

Fig. A2.11b

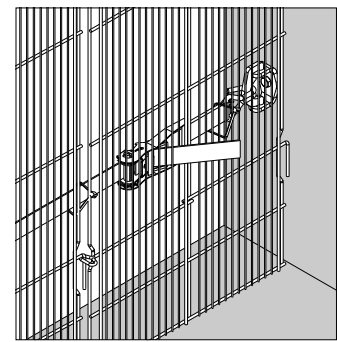

Fig. A2.11a

## Top view

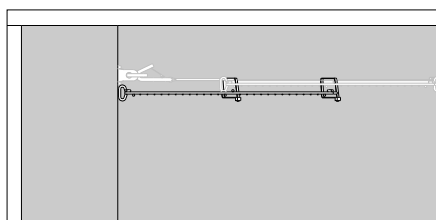

Fig. A2.11c

# A3 Extensions

## Third Tension Belt position

It is required for room-high enclosures.

### Required components:

1	Fold Mesh PFR	
2.1	Tension Belt PTB 12	1x
2.2	Lashing strap with	1x
3	Cable Tie PCT	
4	Eyelet PE	4x
5	Edge protection hose	*x

\* up to 4 pieces depending on the support cross-section.



**Risk of falling! Assembly is to take place with site personnel positioned on a secure working and safety scaffold or with the use of personal protective equipment (PPE)!**



For assembling and dismantling the Fold Mesh PFR, 10 cm free space is required.

### Assembly

1. Mount third tension belt position PTB (2.1 + 2.2). (Fig. A3.01)
2. Place Fold Mesh PFR (1) in a leaning position and determine height below with two Cable Ties PCT (3). Fix laterally at top with one Cable Tie PCT (3). (Fig. A3.02 + A3.02a + 02b)
3. Attach second Fold Mesh PFR (1) to first Fold Mesh PFR and fix below and laterally by means of one Cable Tie PCT (3). (Fig. A3.03 + A3.03a + 03b)

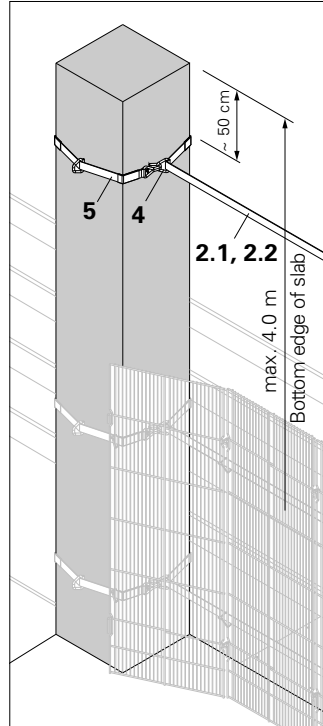

Fig. A3.01

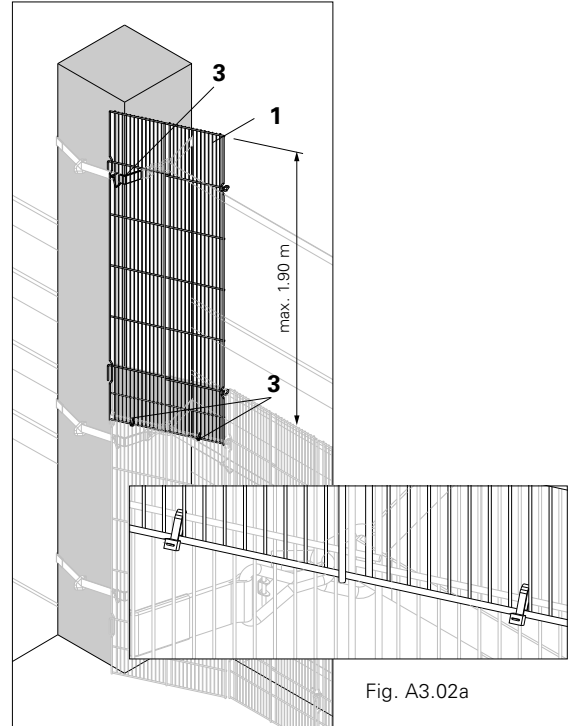

Fig. A3.02

Fig. A3.02a

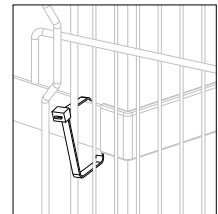

Fig. A3.02a

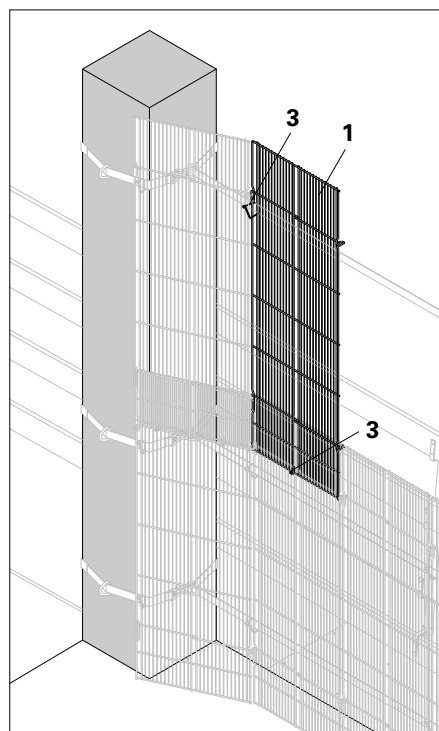

Fig. A3.03

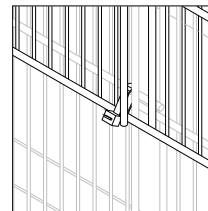

Fig. A3.03a

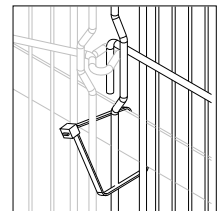

Fig. A3.03b

# A3 Extensions

**Continuous assembly**

- 4. Attach Fold Mesh PFR and determine the height below with Cable Ties PCT.
  - 5. Fix every second Fold Mesh PFR laterally with Cable Ties PCT.
- (Fig. A3.04)

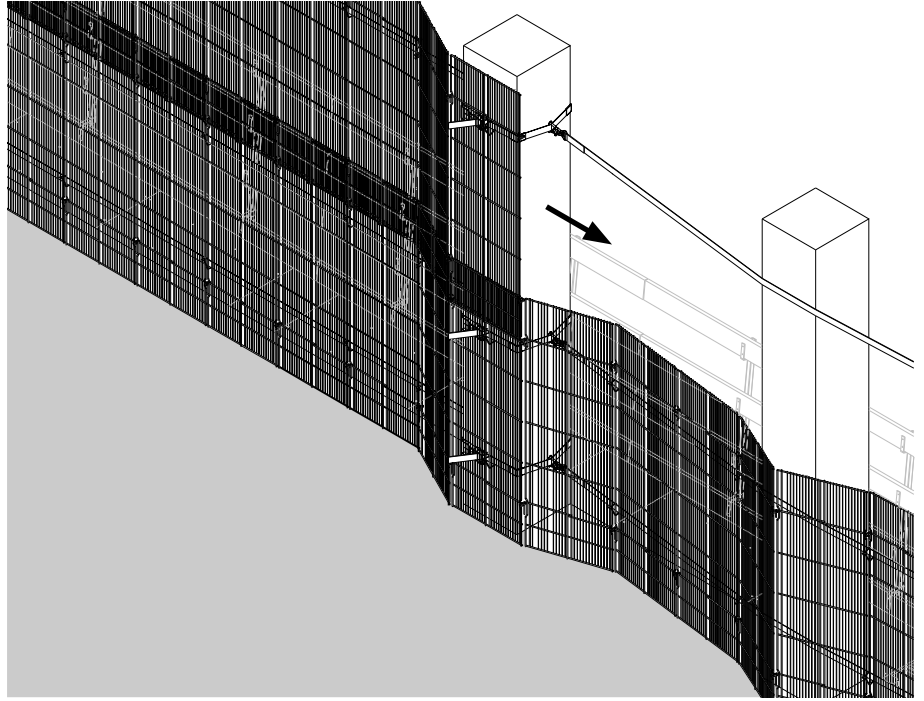

Fig. A3.04

**Always mount the Fold Mesh from a safe working position.**

- From a position on the inside of the building, e.g. with a stripping cart with continuous side protection.
- (Fig. A3.05)

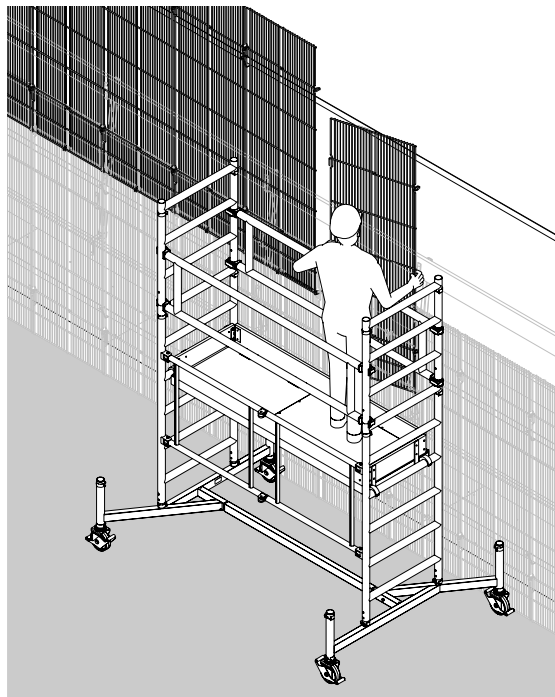
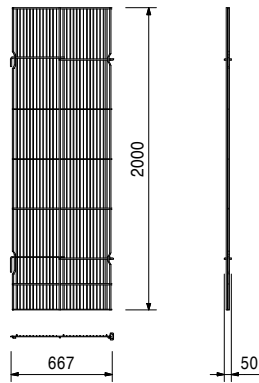
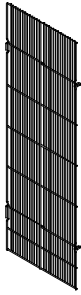

Fig. A3.05

Item no.	Weight kg
118350	7,690

**Fold Mesh room height PFR**  
Requires a horizontal sub-construction.



118349	3,530
--------	-------

**Tension Belt PTB 12**  
Two-piece.

**Technical Data**

Total length 12 m. Max. span 8 m.

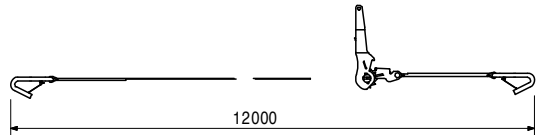
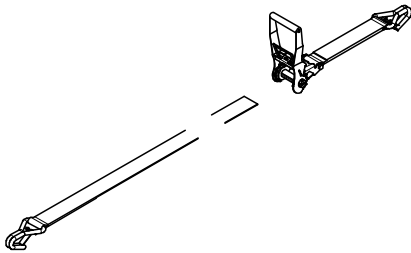

118408	0,006
--------	-------

**Cable Tie PCT**  
For fixing the meshes to the tension belts.

**Technical Data**

Black, UV-resistant.  
Loading capacity: 0.8 kN.

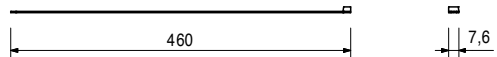
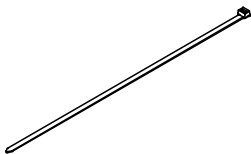

117200	0,244
--------	-------

**Eyelet-2 PE**  
For fixing the hooks of the tension belts.

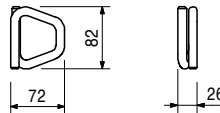

Item no.	Weight kg
118405	0,918

### Wall Fixing PWF

For fixing tension belts to the walls.

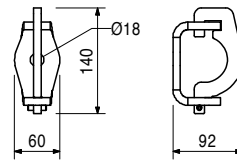

117020	0,213
--------	-------

Accessories

### Anchor Bolt PERI 14 x 150

118494	0,224
--------	-------

### Edge Protector - Hose PEH 1 m

For protecting tension belts and edges.

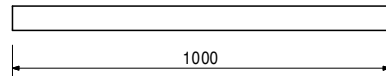
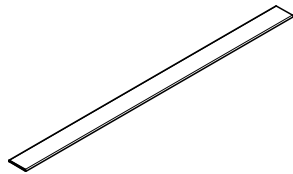

118493	0,137
--------	-------

### Edge Protector - Plate PEP

For protecting edges.

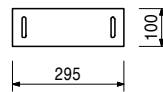
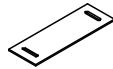

117020	0,213
--------	-------

### Anchor Bolt PERI 14 x 150

Re-usable.

Construction Approval is available on request.

#### Note

For permissible load, see data sheet.

Wrench size SW 22.

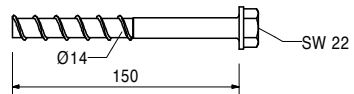
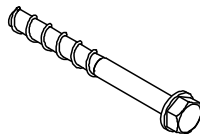

Item no.	Weight kg
035500	72,800

## Stripping Cart Alu

Mobile working scaffold. Height adjustable in 25 cm increments. Platform height: max. 2.0 m.

## Technical Data

Permissible load: 100 kg/m<sup>2</sup>.

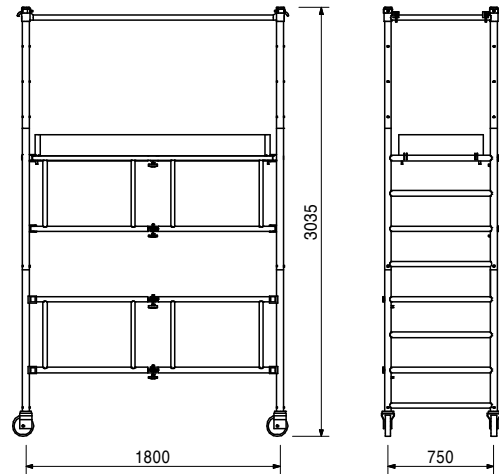
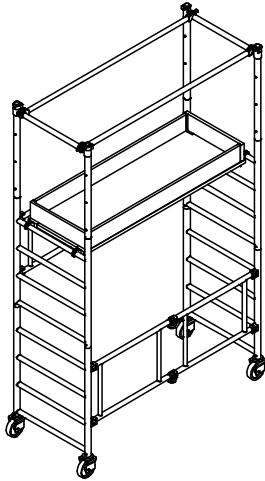











**01 PERI GmbH**  
 Rudolf-Diesel-Strasse  
 89264 Weissenhorn  
 info@peri.com  
 www.peri.com



**02 France**  
 PERI S.A.S.  
 77109 Meaux Cedex  
 peri.sas@peri.fr  
 www.peri.fr

**03 Switzerland**  
 PERI AG  
 8472 Ohringen  
 info@peri.ch  
 www.peri.ch

**04 Spain**  
 PERI S.A.  
 28110 Algete - Madrid  
 info@peri.es  
 www.peri.es

**05 Belgium/Luxembourg**  
 N.V. PERI S.A.  
 1840 Londerzeel  
 info@peri.be  
 www.peri.be

**06 Netherlands**  
 PERI B.V.  
 5480 AH-Schijndel  
 info@peri.nl  
 www.peri.nl

**07 USA**  
 PERI Formwork Systems, Inc.  
 Elkridge, MD 21075  
 info@peri-usa.com  
 www.peri-usa.com

**08 Indonesia**  
 PT Beton Perkasa Wijaksana  
 Jakarta 10210  
 bpw@betonperkasa.com  
 www.peri.com

**09 Italy**  
 PERI S.p.A.  
 20060 Basiano  
 info@peri.it  
 www.peri.it

**10 Japan**  
 PERI Japan K.K.  
 Tokyo 103-0015  
 info@perijapan.jp  
 www.perijapan.jp

**11 United Kingdom/Ireland**  
 PERI Ltd.  
 Rugby, CV23 0AN  
 info@peri.ltd.uk  
 www.peri.ltd.uk

**12 Turkey**  
 PERI Kalıp ve İskeleleri  
 Esenyurt / İstanbul 34510  
 info@peri.com.tr  
 www.peri.com.tr

**13 Hungary**  
 PERI Kft.  
 1181 Budapest  
 info@peri.hu  
 www.peri.hu

**14 Malaysia**  
 PERI Formwork Malaysia  
 Sdn. Bhd.  
 43300 Seri Kembangan,  
 Selangor Darul Ehsan  
 info@perimalaysia.com  
 www.perimalaysia.com

**15 Singapore**  
 PERI ASIA Pte. Ltd  
 Singapore 387355  
 pha@periasia.com  
 www.periasia.com

**16 Austria**  
 PERI Ges.mbh  
 3134 Nußdorf ob der Traisen  
 office@peri.at  
 www.peri.at

**17 Czech Republic**  
 PERI spol. s r.o.  
 252 42 Jesenice u Prahy  
 info@peri.cz  
 www.peri.cz

**18 Denmark**  
 PERI Danmark A/S  
 2670 Greve  
 peri@peri.dk  
 www.peri.dk

**19 Finland**  
 PERI Suomi Ltd. Oy  
 05460 Hyvinkää  
 info@perisuomi.fi  
 www.perisuomi.fi

**20 Norway**  
 PERI Norge AS  
 3036 Drammen  
 info@peri.no  
 www.peri.no

**21 Poland**  
 PERI Polska Sp. z o.o.  
 05-860 Płochocin  
 info@peri.pl.pl  
 www.peri.pl.pl

**22 Sweden**  
 PERIform Sverige AB  
 30013 Halmstad  
 peri@periform.se  
 www.periform.se

**23 Korea**  
 PERI (Korea) Ltd.  
 Seoul 135-080  
 info@perikorea.com  
 www.perikorea.com

**24 Portugal**  
 PERIcofragens Lda  
 2790-326 Queijas  
 info@peri.pt  
 www.peri.pt

**25 Argentina**  
 PERI S.A.  
 B1625GPA Escobar – Bs. As.  
 info@peri.com.ar  
 www.peri.com.ar

**26 Brazil**  
 PERI Formas e  
 Escoramentos Ltda.  
 Vargem Grande Paulista  
 São Paulo  
 info@peribrasil.com.br  
 www.peribrasil.com.br

**27 Chile**  
 PERI Chile Ltda.  
 Colina, Santiago de Chile  
 peri.chile@peri.cl  
 www.peri.cl

**28 Romania**  
 PERI România SRL  
 077015 Balotești  
 info@peri.ro  
 www.peri.ro

**29 Slovenia**  
 PERI Slovenien  
 2000 Maribor  
 peri.slo@triera.net  
 www.peri.com

**30 Slovakia**  
 PERI spol. s r.o.  
 903 01 Senec  
 info@peri.sk  
 www.peri.sk

**31 Australia**  
 PERI Australia Pty. Ltd.  
 Glendenning NSW 2761  
 info@periaus.com.au  
 www.periaus.com.au

**32 Estonia**  
 PERI AS  
 76406 Saku vald  
 Harjumaa  
 peri@peri.ee  
 www.peri.ee

**33 Greece**  
 PERI Hellas Ltd.  
 194 00 Koropi  
 info@perihellas.gr  
 www.perihellas.gr

**34 Latvia**  
 PERI SIA  
 2118 Salaspils novads,  
 Rigas rajons  
 info@peri-latvija.lv  
 www.peri-latvija.lv

**35 United Arab Emirates**  
 PERI (L.L.C.)  
 Dubai  
 perillc@perime.com  
 www.perime.com



- 36 Canada**  
PERI Formwork Systems, Inc.  
Bolton, ON – L7E 1K1  
info@peri.ca  
www.peri.ca
- 37 Lebanon**  
Lebanon Representative Office  
Jdeideh  
lebanon@peri.de  
www.peri.de
- 38 Lithuania**  
PERI UAB  
02300 Vilnius  
info@peri.lt  
www.peri.lt
- 39 Morocco**  
PERI S.A.  
Tanger  
peri25@menara.ma  
www.peri.com
- 40 Israel**  
PERI Formwork  
Engineering Ltd  
Petach Tikva, 49002  
info@peri.co.il  
www.peri.co.il
- 41 Bulgaria**  
PERI Bulgaria EOOD  
1839 Sofia  
peri.bulgaria@peri.bg  
www.peri.bg
- 42 Iceland**  
Armar ehf.  
220 Hafnarfjörður  
www.armor.is
- 43 Kazakhstan**  
TOO PERI Kazakhstan  
050014 Almaty  
peri@peri.kz  
www.peri.kz
- 44 Russian Federation**  
OOO PERI  
142407, Noginsk District  
moscow@peri.ru  
www.peri.ru
- 45 South Africa**  
Wiehahn Formwork and  
Scaffolding (Pty) Ltd.  
7600 Stellenbosch  
info@wiehahn.co.za  
www.wiehahn.co.za
- 46 Ukraine**  
TOW PERI Ukraina  
07400 Brovary  
peri@peri.ua  
www.peri.ua
- 47 Egypt**  
Egypt Branch Office  
11361 Heliopolis / Cairo  
info@peri.com.eg  
www.peri.com.eg
- 48 Serbia**  
PERI Oplate d.o.o.  
11272 Dobanovci  
office@peri.rs  
www.peri.rs
- 49 Mexico**  
PERI Cimbras y Andamios,  
S.A. de C.V.  
Estado de México,  
info@peri.com.mx  
www.peri.com.mx
- 50 Azerbaijan**  
PERI Kalıp ve İskeleleri  
Baku  
peribaku@peri.com.tr  
www.peri.com.tr
- 51 Turkmenistan**  
PERI Kalıp ve İskeleleri  
Aşgabat  
ahmet.kadioglu@peri.com.tr  
www.peri.com.tr
- 52 Belorussia**  
PERI Belarus  
220030 Minsk  
info@peri.by  
www.peri.com
- 53 Croatia**  
PERI oplate i skele d.o.o.  
10 250 Donji Stupnik/  
Zagreb  
info@peri.com.hr  
www.peri.com.hr
- 54 Iran**  
PERI GmbH  
Iran Branch Office  
Tehran  
info@peri.ir  
www.peri.ir
- 55 India**  
PERI (India) Pvt Ltd  
Mumbai – 400064  
info@peri.in  
www.peri.in
- 56 Jordan**  
PERI GmbH - Jordan  
11947 Amman  
jordan@peri.com  
www.peri.com
- 57 Kuwait**  
PERI Kuwait  
13011 Kuwait  
kuwait@peri.com  
www.peri.com
- 58 Saudi Arabia**  
PERI Engineering  
Division of Jamjoom  
Consult Saudi Arabia  
21463 Jeddah  
info@peri.com.sa  
www.peri.com.sa
- 59 Qatar**  
PERI Qatar LLC  
P.O.Box: 31295 - Doha  
info@periqatar.com  
www.periqatar.com
- 60 Algeria**  
Société PERI S.A.S.  
Kouba - Alger  
peri.alger@peri.fr  
www.peri.fr
- 61 Albania**  
PERI Sh.p.k.  
Tirane  
erti.hasanaj@peri.com.tr  
www.peri.com.tr
- 62 Peru**  
PERI Peruana SAC  
Villa El Salvador, Lima  
contacto@peri.com.pe  
www.peri.com.pe
- 63 Panama**  
PERI Panama Inc.  
0832-00155 Panama City  
info@peri.com.pa  
www.peri.com.pa
- 64 Angola**  
PERIcofragens, Lda.  
Luanda  
renato.portugal@peri.pt  
www.peri.pt
- 65 Nigeria**  
Heights Access Nigeria Ltd.  
Victoria Island, Lagos  
info@heightsaccessng.com  
www.heightsaccessng.com
- 66 Oman**  
PERI (L.L.C.)  
Muscat  
perimct@perime.com  
www.perime.com

# The optimal System for every Project and every Requirements



Wall Formwork



Column Formwork



Slab Formwork



Climbing Systems



Tunnel Formwork



Bridge Formwork



Shoring Systems



Construction Scaffold



Facade Scaffold



Industrial Scaffold



Access



Protection Scaffold

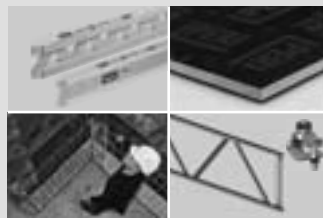

System-Independent Accessories



Services



**PERI GmbH**  
**Formwork Scaffolding Engineering**  
 P.O. Box 1264  
 89259 Weissenhorn  
 Germany  
 Tel. +49 (0)7309.950-0  
 Fax +49 (0)7309.951-0  
 info@peri.com  
 www.peri.com