

# **VGW** Cantilevered Parapet Carriage

Instructions for Assembly and Use – Standard Configuration – Version 2.0

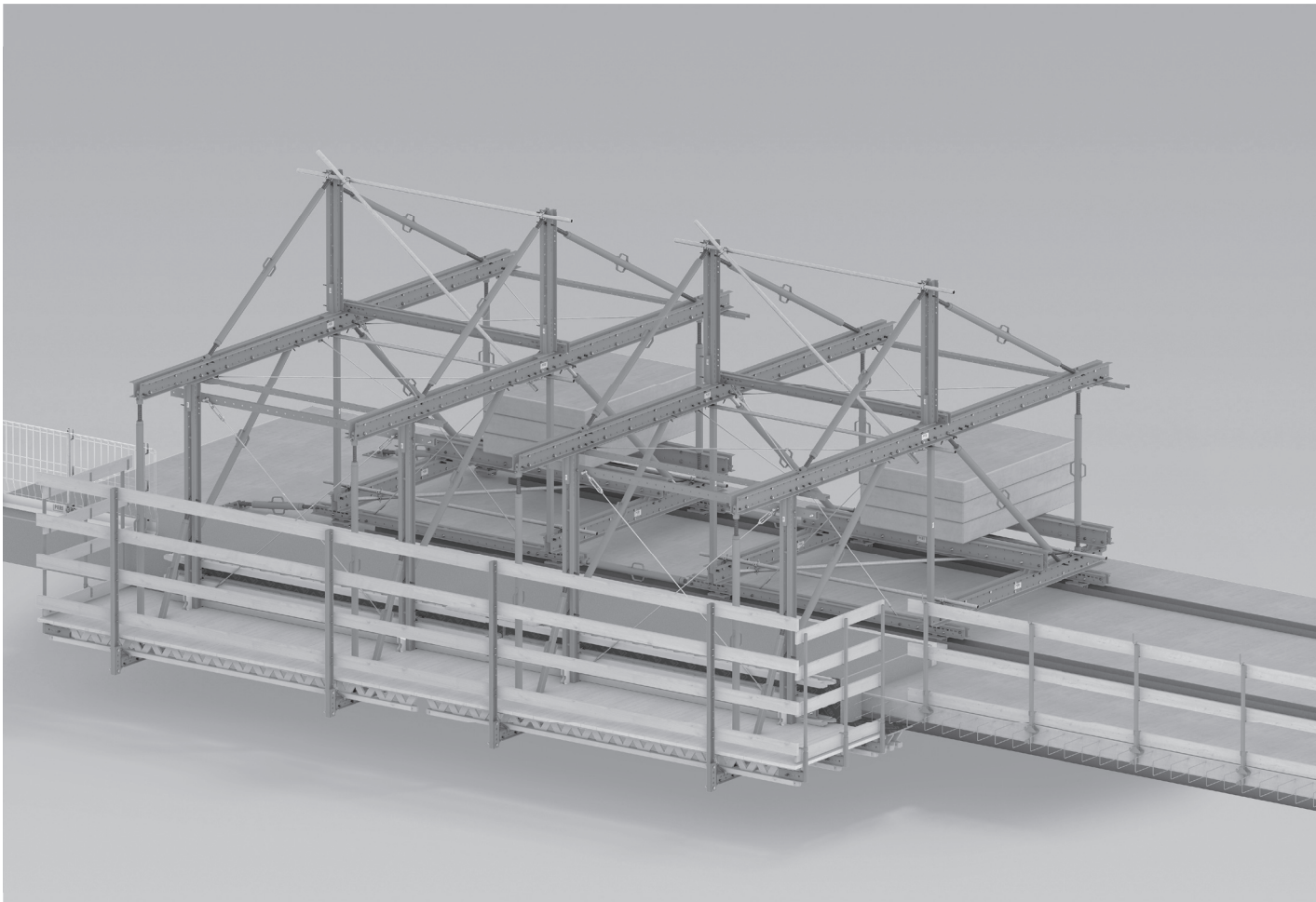



<b>Overview</b>			
Main components	4		
Key	5		
<b>Introduction</b>			
Target groups	6		
Intended use	7		
Instructions for Use	7		
Cleaning and maintenance instructions	8		
Storage and transportation	9		
Additional technical documentation	9		
<b>Safety instructions</b>			
Cross-system	10		
System-specific	12		
<b>Component overview and tool list</b>			
Parts list	14		
Tool list	15		
Tightening torques	15		
<b>System overview</b>			
A1 Load conditions	16		
Working/concreting	16		
Moving the carriage	16		
A2 Planking and guardrails	17		
Platform decking	17		
Guardrails	18		
Variant 1: Guardrail Post GKB	19		
Variant 2: Post PP	21		
A3 Pre-assembly of Climbing Rail RCS	23		
Spacers	23		
<b>Pre-assembly</b>			
B1 Assembly instructions	24		
Preparing for assembly	24		
Load-bearing capacity	24		
Safety instructions	24		
Assembly using three assembly units	25		
B2 Travelling unit	26		
Fitting the heavy-duty roller gear	26		
Fitting the carrier bar	27		
Fitting the ballast support	28		
Fitting the bracing	29		
B3 Kicker braces	30		
Fitting the kicker braces	30		
Fitting the bracing	33		
B4 Concreting platform	35		
Slab formwork	35		
Front-mounted guardrails	37		
Side formwork on standard platforms	38		
Side formwork on leading platform and finishing platform	40		
Completing the concreting platform	41		
Arrangement of leading platform, standard platform and finishing platform	43		
<b>Assembly</b>			
C1 Positioning the travelling unit	44		
C2 Fitting the kicker braces	45		
Preparation	45		
Connecting the kicker braces and travelling unit	47		
C3 Attaching the concreting platform	48		
General information	48		
C4 Anchoring the formwork carriage units	50		
Anchoring in the longitudinal direction	50		
C5 Linking the formwork carriage units	51		
Linking the formwork carriage units	51		
<b>Application</b>			
D1 Shuttering the cantilevered parapet	52		
Sequence of operation	52		
Adjusting the slab formwork	54		
Adjusting the side formwork	54		
Adjusting the height	54		
Connecting the concreting platforms	55		
D2 Concreting the cantilevered parapet	56		
Concreting position	56		
D3 Striking the cantilevered parapet	57		
D4 Relocating the cantilevered parapet carriage	58		
<b>Disassembly and removal</b>			
E1 Disassembly	60		
Striking the cantilevered parapet	60		
Removing the kicker braces	60		
Dismantling the concreting platform	61		
Disassembling the kicker braces	62		
Removing the ballast	63		
Disassembling the travelling unit	63		
<b>Program overview</b>			
VGW Cantilevered Parapet Carriage	64		

## Main components

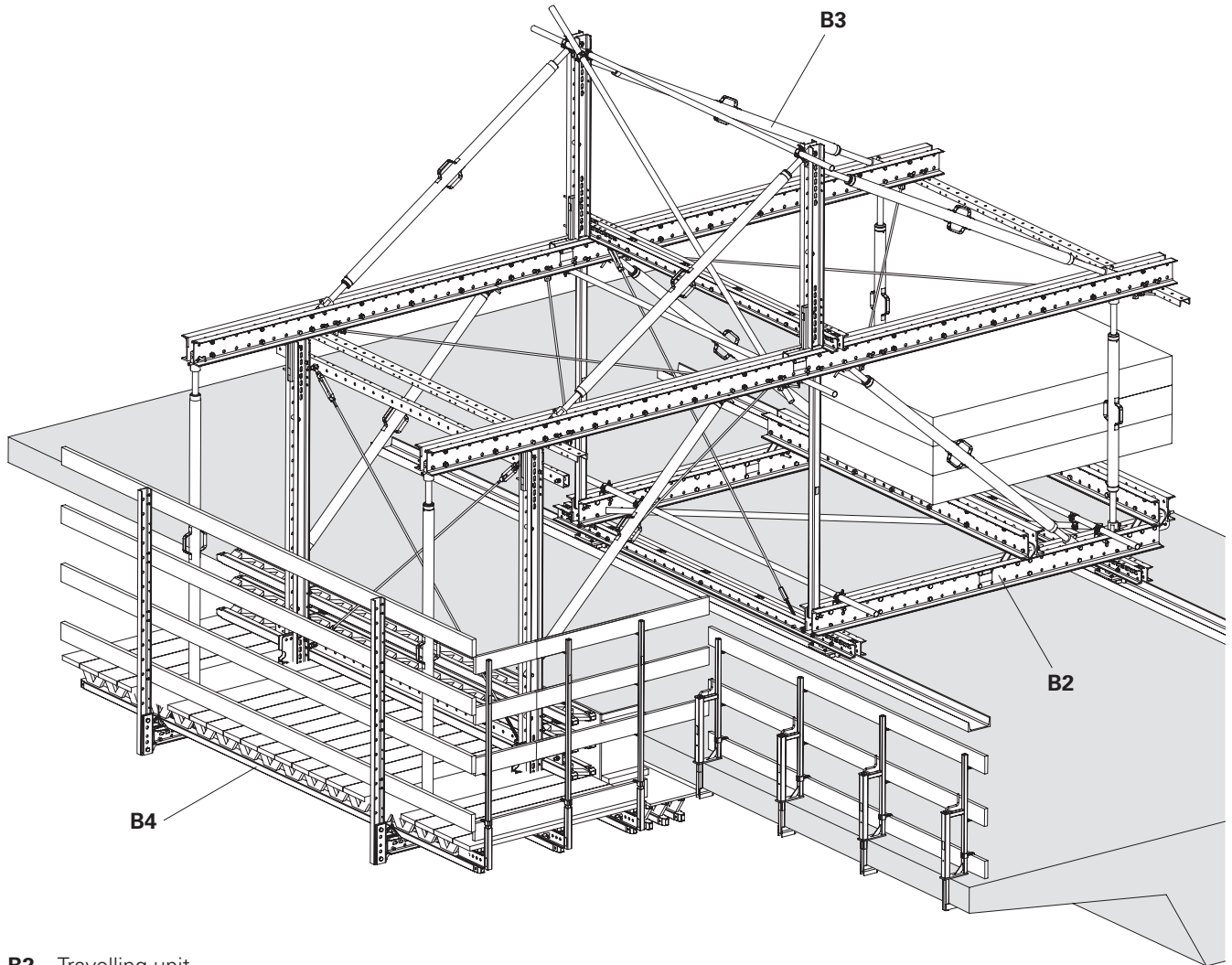

- B2** Travelling unit
- B3** Kicker braces
- B4** Concreting platform

## Key

### Pictogram | Definition



Danger/Warning/Caution



Note



To be complied with



Load-bearing point



Visual inspection



Tip



Incorrect use



Safety helmet



Safety shoes



Safety gloves



Safety goggles



Personal protective equipment to prevent falling from a height (PPE)

### Arrows



Arrow representing an action



Arrow representing a reaction of an action\*



Arrow representing forces

\* If not identical to the action arrow.

### Safety instruction categories

The safety instructions alert site personnel to the risks involved and provide information on how to avoid these risks. Safety instructions can be found at the beginning of the section or before instructions for action and are highlighted as follows:



#### Danger

This sign indicates an extremely hazardous situation which could result in death or serious, irreversible injury if the safety instructions are not followed.



#### Warning

This sign indicates a hazardous situation which could result in death or serious, irreversible injury if the safety instructions are not followed.



#### Caution

This sign indicates a hazardous situation which could result in minor or moderate injury if the safety instructions are not followed.



#### Note

This sign indicates situations in which failure to observe the information can result in material damage.

### Format of the safety instructions



#### Signal word

Type and source of hazard!  
Consequences of non-compliance.  
⇒ Preventative measures.

### Dimensions

Dimensions are usually given in cm. Other measurement units, e.g. m, are shown in the illustrations.

### Conventions

- Instructions are numbered with: 1. ...., 2. ...., 3. ....
- The result of an instruction is shown by: →
- Position numbers are clearly provided for the individual components and are given in the drawing, e.g. **1**, in the text in brackets, for example **(1)**.
- Multiple position numbers, i.e. alternative components, are represented with a slash: e.g. **1/2**.

### Notes on illustrations

The illustration on the front cover of these instructions is understood to be a system representation only. The assembly steps presented in these Instructions for Assembly and Use are shown in the form of examples with only one component size. They are valid for all component sizes contained in the standard configuration.

To facilitate understanding, detailed illustrations are sometimes incomplete. The safety equipment that might not be shown in these detailed illustrations must nevertheless be available.

## Target groups

### Contractor

These Instructions for Assembly and Use are designed for contractors who either

- assemble, modify and dismantle PERI products, or
- use them, e.g. for concreting, or
- allow them to be used, e.g. for forming operations.

### The Safety and Health Protection Coordinator\*

- is appointed by the client,
- must identify potential hazards during the planning phase,
- determines measures that provide protection against risks,
- creates a safety and health protection plan,
- coordinates the protective measures for the contractor and site personnel so that they do not endanger each other,
- monitors compliance with the protective measures.

### Competent person

(Construction Site Coordinator)

- is appointed by the contractor,
- must be on site for all work,
- prepares and updates the plan for assembly, modification and dismantling,
- prepares and updates the plan for use of the formwork by the user,
- supervises the assembly, modification and dismantling work (supervisor).

### Competent persons qualified to carry out inspections

Due to the specialist knowledge gained from professional training, work experience and recent professional activity, the competent person qualified to carry out inspections has a reliable understanding of safety-related issues and can carry out inspections correctly. Depending on the complexity of the inspection to be undertaken, e.g. scope of testing, type of testing or the use of certain measuring devices, a range of specialist knowledge is necessary.

### Qualified personnel

PERI products may only be assembled, modified or dismantled by personnel who are suitably qualified to do so.

Qualified personnel must have completed a course of training\*\* in the work to be performed, covering the following points at least:

- Explanation of the plan for the assembly, modification or dismantling of the system in an understandable form and language.
- Description of the measures necessary to safely assemble, modify or dismantle the PERI product.

- Designation of the preventive measures to be taken to avoid the risk of persons and objects falling.
- Designation of the safety precautions in the event of changing weather conditions that could adversely affect the safety of the PERI products, as well as the personnel concerned.
- Details regarding permissible loads.
- Description of all other risks and dangers associated with assembly, modification or dismantling operations.



- **In other countries, ensure that the relevant national guidelines and regulations in the respective current version are complied with!**
- **If no country-specific regulations are available, it is recommended to proceed according to German guidelines and regulations.**
- **A competent person must be on site when any work is carried out on the PERI product.**

\* Valid in Germany: Regulations for Occupational Health and Safety on Construction Sites 30 (RAB 30).

\*\* Instructions are given by the contractor themselves or a competent person selected by them.

## Intended use

### Product description

PERI products have been designed for exclusive use in the industrial and commercial sectors only by suitably trained personnel.

VGW Cantilevered Parapet Carriages are used for concreting and refurbishing cantilevered parapets on bridges cast in-situ or constructed using prefabricated elements.

They are used as assembly carts for the installation of supply lines beneath the bridge.

Main components are standardised PERI components taken from the VARI OKIT Engineering Construction Kit.

A kicker brace with upper lashing forms the basis for a formwork carriage unit. The kicker brace is fastened to the travelling unit with standardised fitting pin connections.

The load is introduced into the bridge using mobile rolling-contact bearings that are positioned in U-sections.

Wind bracing and other reinforcement on the kicker brace stiffen the structure and provide the required level of stability.

### Features

- Mobile solution for quick relocation of cantilevered parapet formwork.
- Anchoring to the building structure is not normally required.
- Shuttering and striking in two steps.
- Suitable for working at great heights.
- Up to four formwork carriage units can be linked to one another.
- The cantilevered parapet carriage can be adapted to suit different parapet geometries and carriageway radii.
- There is the option of combining the cantilevered parapet carriage with a hydraulic winch system in order to pull it to the next concreting section.
- Project-specific planning is required.

### Technical data

- Recommended bridge length: at least 50 – 60 m or 15 m to 20 m per concreting section and 5 to 6 relocation operations.
- A cantilevered parapet carriage consists of 3 to 4 formwork carriage units.
- Longitudinal inclination up to 4 %.
- Lateral inclination up to 6 %.
- Project-specific planning will determine the total weight.
- Temperature range: -20 °C to +60 °C

### Foreseeable misuse

- Transportation of loads and persons.

---

## Instructions for Use

Use in a way not intended, deviating from the standard configuration or the intended use according to the Instructions for Assembly and Use, represents a misapplication with a potential safety risk, e.g. risk of falling.

Only PERI original components may be used. The use of other products and spare parts is not allowed and represents a misapplication with associated safety risks.

Changes to PERI components are not permitted.

Only ever use approved and calculated components.

Operation with damaged or incomplete load-carrying equipment is not permissible.

The system described in these Instructions for Assembly and Use may contain patent-protected components.



- The description of the assembly and operation of the assemblies and components in these Instructions for Assembly and Use is intended as an example.
- For use on the construction site, a project-specific assembly plan is required.
- The project-related assembly plan from PERI is binding for assembly operations.

## Cleaning and maintenance instructions

In order to maintain the value and operational readiness of the materials over the long term, clean the panels after each use.

Some repair work will be inevitable due to the working conditions.

The following instructions should help to keep cleaning and maintenance costs as low as possible.

Spray the formwork on both sides with concrete release agent before each use. This will make the formwork quicker and easier to clean. Spray the concrete release agent very thinly and evenly.

Do not spray work platforms and access routes with concrete release agent.

Slip hazard.

Spray the rear side of the formwork with water immediately after concreting; this avoids any time-consuming and costly cleaning operations.

When used continuously, spray the formlining elements with concrete release agent immediately after striking; then clean by means of a scraper, brush or rubber lip scraper.

Important: do not clean formlining made of plywood with high-pressure equipment. This could result in the formlining being damaged.

Fix recesses and built-in parts with double-headed nails; as a result, the nails can easily be removed later, and damage to the formlining is largely avoided.

Close all unused tie holes with plugs; this eliminates any subsequent cleaning or repair work.

Tie holes accidentally blocked with concrete are cleared by means of a steel pin from the formlining side.

When placing bundles of reinforcement bars or other heavy objects on horizontally stored formwork elements, suitable support, e.g. square timbers, is to be used: this prevents impressions and damage to the formlining to a large extent.

Internal concrete vibrators should be fitted with rubber caps if possible; as a result, any damage to the formlining is reduced if the vibrator is accidentally inserted between the reinforcement and formlining.

Never clean powder-coated components, e.g. elements and accessories, with a steel brush or hard metal scraper; this ensures that the powder coating remains intact.

Use spacers for reinforcement with large-sized supports or extensive areas of support; this largely avoids impressions being formed in the formlining when under load.

Mechanical components, e.g. spindles or gear mechanisms, must be cleaned of dirt or concrete residue before and after use, and then greased with a suitable lubricant.

Provide suitable support for the components during cleaning so that no unintentional change in their position is possible.

Do not clean components suspended on crane lifting gear.



## Storage and transportation

Store and transport components in such a way that no unintentional change in their position is possible. Detach lifting accessories and lifting gear from the lowered components only if they are in a stable position and no unintentional change is possible.

Do not drop the components.

Pre-assembled assemblies should always be guided with ropes when moving them by crane.

Use PERI lifting accessories and lifting gear and only those load-bearing points provided on the component.

During the relocation procedure

- ensure that components are picked up and set down in such a way that unintentional falling over, falling apart, sliding, falling down or rolling is avoided.
- no one is allowed to remain under the suspended load.

The access areas on the construction site must be free of obstacles and tripping hazards, and must also be slip-resistant.

For transportation, the substrate must have sufficient load-bearing capacity.

Use original PERI storage and transport systems, e.g. crate pallets, pallets or stacking devices.

---

## Additional technical documentation

- Instructions for Assembly and Use:
  - PROKIT EP 110 Safety System
  - VARIO GT 24 Girder Wall Formwork
- Instructions for Use:
  - Pallets and stacking devices
- Data sheet:
  - PERI Screw-On Sleeve M16/164
- PERI Design Tables:
  - Design Tables 2015 – Formwork and Shoring
- Product brochure:
  - VARIOKIT Cantilevered Parapet Systems
  - VARIO GT 24

## Cross-system



### Safety instructions apply to all service life phases of the system.

#### General

The contractor must guarantee that the Instructions for Assembly and Use supplied by PERI are available at all times and understood by the site personnel.

These Instructions for Assembly and Use and project-specific documents can be used as the basis for creating the risk assessment. The risk assessment is compiled by the contractor. The Instructions for Assembly and Use are not a substitute for a risk assessment!

Observe and comply with the safety instructions and permissible loads.

For the application and inspection of PERI products, the current safety regulations and guidelines valid in the respective countries must be observed.

Materials and working areas are to be inspected before each use and assembly for:

- damage,
- stability and
- functional correctness.

Damaged components must be exchanged immediately on site and may no longer be used.

Safety components are to be removed only when they are no longer required.

When on slab formwork, scaffolds and working platforms:

- do not jump,
- do not run,
- do not throw anything off them.

Components provided by the contractor must comply with the requirements stipulated in these Instructions for Assembly and Use, the project-specific documents, and all applicable laws and standards. Unless otherwise indicated, the following applies in particular: Unless otherwise indicated, the following applies in particular:

- Timber components:  
Strength class C24 for solid wood according to DIN EN 338:2016-07.
- Scaffolding tubes:  
Galvanised steel tubes with minimum dimension  $\varnothing 48.3 \times 3.2$  mm according to  
DIN EN 12811-1:2004-03 4.2.1.2.
- Scaffolding tube couplings:  
according to DIN EN 74-1:2005-12 and DIN EN 74-2:2009-01.

Deviations from the standard configuration are only permitted after a further risk assessment has been carried out by the contractor.

Appropriate measures for working and operational safety, as well as stability, are defined on the basis of this risk assessment.

Corresponding proof of stability can be provided by PERI if required, if the risk assessment and resulting measures to be implemented are made available.

Nails and wood screws must not protrude.

Only allow other connecting components to protrude as far as necessary. If necessary, mark protruding components or fit them with protective material.

Secure all bolts with cotter pins and all screws with nuts.

Before and after extraordinary events that may have damaging effects on the safety of the system, the contractor must immediately

- produce another risk assessment and make use of its results to take suitable steps to guarantee the stability of the scaffold,
- arrange for an extraordinary inspection to be carried out by a competent person qualified to do so. The aim of this inspection is to identify and rectify any damage in good time in order to guarantee safe use of the heavy-duty truss girder.

Exceptional events could be:

- accidents,
- long periods of non-use,
- natural events, e.g. heavy rainfall, icing, heavy snowfall, storms or earthquakes.

## Assembly, modification and dismantling work

Assembly, modification or dismantling of heavy-duty truss girders may only be carried out by qualified persons under the supervision of a competent person. The qualified personnel must have received appropriate training for the work to be carried out with regard to specific risks and dangers.

On the basis of the risk assessment, the Instructions for Assembly and Use, and the project-specific documents, the contractor must create installation instructions to guarantee safe assembly, modification and dismantling of the heavy-duty truss girder.



The contractor must ensure that the personal protective equipment required for the assembly, modification or dismantling of the shoring system, e.g.

- safety helmet,
- safety shoes,
- safety gloves,
- safety goggles,

is available and used as intended.

For work at a higher level, use an approved ladder or platform system, or an assembly scaffold.



If personal protective equipment against falling from a height (PPE) is required or specified in local regulations, the contractor must determine appropriate attachment points on the basis of the risk assessment.

The PPE to be used to prevent falling is determined by the contractor.

The contractor must

- provide safe working areas for site personnel, which are to be reached through the provision of safe access ways. cordon off and clearly mark danger zones.
- guarantee stability during all stages of construction, in particular during assembly, modification and dismantling operations.
- ensure and demonstrate that all loads that occur are safely transferred.

## Use

Before initial use, the safe functioning of the heavy-duty truss girder must be checked by a person qualified to carry out the inspection. The results of the inspection must be documented in an inspection log.

Every contractor who uses or allows the scaffolding systems or sections of the scaffolding system to be used, is responsible for ensuring that the equipment is in good condition.

If the scaffold is used successively or at the same time by several contractors, the health and safety coordinator must point out any possible mutual hazards and all work must be then coordinated.

## Notes for use

- Working areas must remain free of any tripping hazards.
- Do not walk on components and assembly units, always ensure that they are in a secure position.
- Always keep components and assembly units free of dirt, ice and snow. In wet weather conditions in particular, there is an increased risk of slipping.
- Always keep work platforms clean.
- Do not remain in the danger zone created by the moving parts.
- Avoid installing working areas and access routes in danger zones.
- Cordon off danger zones.
- Ensure that the guardrails and edge covers are fully installed.

## System-specific



### **Safety instructions apply to all service life phases of the system.**

Make sure that the guardrails and/or edge covers at building openings and projections are fully installed before accessing the climbing/formwork system.

Strike components only when the concrete has sufficiently hardened and the person in charge has given the go-ahead for striking to take place.

Anchoring is to take place only if the anchorage has sufficient concrete strength.

Inspection of the anchoring and associated components must be carried out by the party responsible.

As a result of the relocation procedure, falling edges are formed between the platforms. Such affected areas are to be cordoned off.

Site personnel, construction materials or tools must not be transported with the crane during relocation operations. Exceptions to this can be determined through the operational working and assembly instructions.

Operational working areas at great heights are to be secured by means of appropriate measures to prevent objects from falling down.

The enclosure of the platform or mounting of additional surfaces exposed to the wind changes the degree of stability and must be rechecked. If necessary, additional measures must be implemented.

Use a guide rope to ensure that assembly units suspended from the crane are fully under control when being moved.

Welding and/or abrasive cutting work must not be carried out on the platforms.

Reliable lightning conduction must be ensured by the contractor.

### **Assembly work**

The contractor must ensure that the user has an appropriate and sufficient number of tools, lifting equipment and slings, suitable and sufficient space for assembly and storage as well as adequate crane capacity at his disposal.

During the transportation procedure, only use the specified attachment points for components.

Avoid standing under suspended loads. If work under suspended loads cannot be avoided, come up with suitable safety measures and apply them. Avoid standing between a fixed object and an object that is drawing near.

Secure interim assembly states by means of temporary supports in order to prevent any items from toppling over.

The contractor must make a level assembly area with sufficient load-bearing capacity available.

Unexpected hazards can always arise when assembly work is carried out. Assess the degree of risk in each individual case and, if necessary, take measures to prevent or minimise the risk.

If anti-fall protection cannot be used or has to be removed due to operational reasons, safety equipment must be installed in its place in order to prevent falls from any height.

If the use of anti-fall equipment is deemed to be inappropriate, personal protection equipment (PPE) can be used if suitable fixing points are available.

Site personnel are forbidden to remain in areas below where assembly work is being carried out, unless the danger zone has been provided with sufficient protection against falling, overturned, sliding or rolling objects and masses. Cordon off and clearly mark any danger zones and check that these are in place and complete every time work is commenced.

Do not walk on components and assembly units.

Find a secure standing position next to the components or assembly units. Use assembly scaffolds.

## Means of access

Safe access to all working areas must be guaranteed at all times.

Hatches and openings to accessible working areas must be kept closed during working operations.

Use walkways, stairs, stair towers or site lifts. Ladders are suitable for use as passageways in exceptional cases only.

Ladders must not be connected to each other for more than two levels and should be offset against one another.

Ladders must be secured on the outer side by means of appropriate anti-fall equipment such as ladder cages or safety nets.

Building edges at passages and openings in accessible areas must be secured.

In case of danger, it must be ensured that working areas can be vacated via emergency escape routes or rescue equipment.

It must also be ensured that at least one emergency escape route or piece of rescue equipment can still be used if the power supply fails. Determine and apply all appropriate measures.

Throughout the entire relocation procedure, ensure that site personnel can still use the emergency escape route.

## Protection against falling components

Work activities may not be carried out simultaneously on areas positioned on top of each other if the lower working areas are not protected against falling objects.

Avoid installing working areas and access routes in danger zones. If this is not possible due to work procedures, suitable protective measures must be available to provide protection against falling objects. This also applies to work that only takes a short period of time.

Safety nets (mesh size  $\leq 2$  cm) and platform planking are considered to be suitable means and are to be installed very close to the structure (distance  $\leq 5$  cm).

Secure all bolts with cotter pins and all screws with nuts.

Secure tools and material to prevent them from falling down. Remove concrete residue and other forms of dirt as quickly as possible. The platforms are to be kept clean at all times.

Operational working areas at great heights are to be secured by means of appropriate structural measures to prevent objects from falling down.

## DGUV 201-011 [German Statutory Accident Insurance] (formerly BGI 663)

"Handling instructions for the use of work and safety scaffolding"

Extract taken from Section 7:

- For their own safety, it is important that site personnel use the designated access means for ascents and descents, and do not climb or jump off the scaffold.
- Do not jump on the scaffold decks nor throw any objects off the side.

## Components at risk of structural collapse

Secure components that are likely to become unstable with suitable means, e.g. using push-pull props, or leave them attached to the crane until the tipping hazard has been eliminated.

Loitering in the tipping range is prohibited. Draw attention to and clearly mark any danger zones.

If necessary, cordon off the danger zones with suitable means. Check that safety signs and barriers are in place before commencing work.

## Supporting structure

A visual inspection is to be carried out by authorised personnel before initial use.

Only PERI original components are to be used for repairs or replacement.

In the case of overloading or recurrent damage, stop work operations on and under the platforms, determine the cause and rectify.

Pos. no.	Component name	Article no.	Pos. no.	Component name	Article no.
	<b>Travelling unit</b>		33	Guardrail Post SGP	061260
1	Climbing Rail RCS 348	109470	34	Guardrail Post RCS 226	109720
2	Heavy-Duty Roller Gear 150 kN, series B-II	022040	35	Squared timber 14/14 cm	
3	Heavy-Duty Roller Gear Connection VARIOKIT	111274	36	Planking 24 x 4 cm	
4	Cross Connector RCS	123509	37	Planking 20 x 4.5 cm	
5	Base Plate-2 for RS 1000/1400	102018	38	Handrail board 15/3 cm	
6	Steel Waler Universal SRU U120, L = 3.97 m	103915	39	Handrail board 12/4 cm	
7	Bracing Shoe RCS DW 15	114997	40	Formlining	
8	Diagonal Strut RCS 212	110012	41	Binding wire	
	<b>Spindles</b>		42	U-section	
9	Heavy-Duty Spindle SLS 80/140	101773	43	Scaffold stand 1.5 t	
10	Heavy-Duty Spindle SLS 140/240	101776	44	Guardrail Post GKB	114299
11	Heavy-Duty Spindle SLS 200/300	101778	45	Timber strap	
12	Heavy-Duty Spindle SLS 260/360	101779	46	Rear formwork	
13	Spindle Adapter SLS/RCS	110477	47	Relocation device	
	<b>Kicker brace</b>		48	Post PP	117325
14	Climbing Rail RCS 748	109472	49	Slab Foot PDF	117323
15	Elbow Connection RCS/SRU	111283		<b>Fastener</b>	
16	Steel Waler Universal SRU U120, L = 1.72 m	103886	50	Bolt 20 x 140	105395
	<b>Wind bracing and other reinforcement</b>		51	Fitting pin Ø 21 x 120	104031
17	Scaffold Tube Holder RCS Ø 48	110084	52	Cotter pin 4/1	018060
18	Swivel Coupling DK 48/48	017010	53	Fitting pin Ø 26 x 120	111567
19	Guardrail Post RCS 384	109721	54	Cotter pin 5/1	022230
20	Diagonal Bracing DW 15 ACS	057083	55	Bolt ISO 4017 M16 x 50-8.8	710252
21	Bracing Connector RCS DW 15/M20	123534	56	Washer DIN 434 18	710880
22	Cam Nut DW 15	030130	57	Nut ISO 7042 M16-8	070890
23	Cross Connector VARIOKIT	111279	58	Bolt ISO 4014 M20 x 120-8.8	104477
24	Tie Rod DW 15, special length	030030	59	Nut ISO 7040 M20-8	781053
25	Steel scaffolding tube Ø 48.3 x 3.2 Special length	026415	60	FI-Rd Bolt M8 x 70-8.8	126228
26	Ballast		61	Nut ISO 7040 M8-8	711071
	<b>Concreting platform</b>		62	Wood screw	
27	Steel Waler Universal SRU U120, L = 2.97 m	103903	63	Wire nail	
28	Steel Waler Universal SRU U120, L = 2.22 m	103898	64	Heavy-duty dowel	
29	Universal Coupling UK 70	103737	65	PERI Screw-On Sleeve M16/164	123970
30	Hook Strap Uni HBU 24-28	103845	66	Bolt ISO 4014 M16 x 120-8.8	105402
31	Formwork Girder GT 24 L = 5.40 m	075540	67	Washer ISO 7094 16-100 HV	113349
31a	Formwork Girder GT 24 L = 4.80 m	075480	68	Spacer M20-82	110022
32	Guardrail Holder GT 24/VT 20	101290	69	Spacer M24-82	110023
			72	Steel Waler Universal SRU U120, L = 3.47 m	103906

Tool name	Article no.
Hammer 500 g	
Open-End Wrench AF 27	
Tool Set ACS	051761

## Tightening torques

Unless otherwise indicated, PERI recommends the following guide values for screw connections as "hand-tightened" tightening torques  $M_{A,hand-tightened}$ . These guide values are based on EN 15048 with minimum Safety Factor 3 against breakage.

Quality class	Quality 4.6		Quality 8.8 and 10.9
	Lightly oiled	MoS2	undefined
Screw M8	8 Nm	6.6 Nm	8 Nm
Screw M10	16 Nm	13.0 Nm	16 Nm
Screw M12	30 Nm	23.0 Nm	30 Nm
Screw M16	65 Nm	54.0 Nm	65 Nm
Screw M20	100 Nm		100 Nm
Screw M24	150 Nm		150 Nm
Screw M30	260 Nm		260 Nm
Screw M36	350 Nm		350 Nm

Tightening torques have been determined for the following components:

Scaffolding tube coupling	50 Nm
Clamping plate for the slab tie gauge	120 Nm

Tie loads have been determined for Tie Plate DW 20 and DW 26.

Lubrication: grease the thread and contact area of the nuts.

Tie Plate DW 20 with Wing Nut DW 20	Fig. 1	150 kN
Tie Plate DW 26 with Hex. Nut DW 26 AF 46/80	Fig. 2	250 kN
Tie Plate DW 26 with Hex. Nut DW 26 AF 46/150		

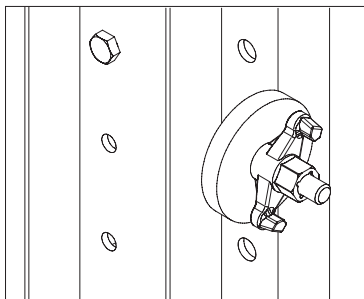

Fig. 1

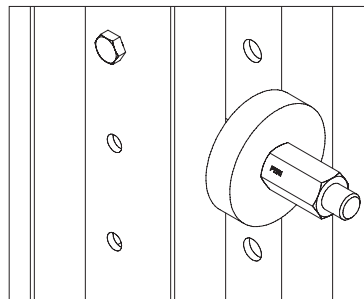

Fig. 2

## Danger

Load specifications must not be exceeded!

There is the risk that the VGW Cantilevered Parapet Carriage will fall down.

- ⇒ Do not place any materials or other objects anywhere on the VGW Cantilevered Parapet Carriage.
- ⇒ For "Load Case: Concreting", only access the work platform to carry out inspection work.

## Working/concreting

The supporting structure of the VGW C antilevered Parapet Carriage is to be provided with project-specific verification by means of a static calculation on the basis of PERI product information as well as valid standards.

Work procedures in "Load Case: Working":

- Cleaning the formwork.
- Installing reinforcement in the cantilevered parapet.
- Closing the formwork.
- Concreting.
- Striking.
- Inspection and maintenance.

## Moving the carriage

### Danger

Unsecured concrete edge!

A fall can result in serious injuries or even death.

⇒ Use PPE.



- Do not exceed load limits.
- Do not place any materials or other objects on the concreting platform of the VGW Cantilevered Parapet Carriage.

### Preparation

Before moving the carriage, the formwork must be released from the building by turning the Heavy-Duty Spindles SLS (10) and (11) or (12a). (Fig. A1.01)

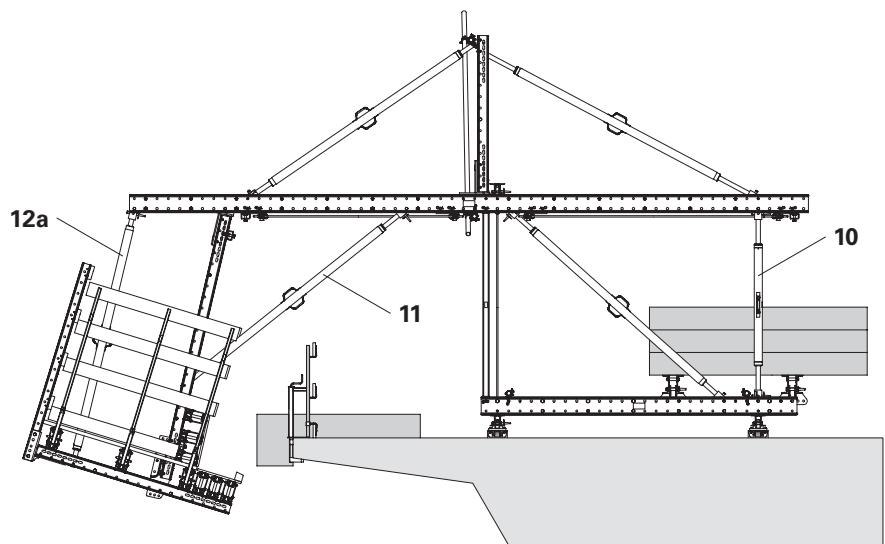

Fig. A1.01





- Only access the VGW Cantilevered Parapet Carriage once it has been checked and approved by the construction site management or another competent person.
- Separate static proof is required for the installation of cantilevered planking.

### Platform decking

Dimensioning of the platform planking is carried out according to the country-specific, applicable standards. (For Germany, DIN 4420-1 can be used.)

Minimum dimensions of the planking:  
 $b \times d = 24 \times 4 \text{ cm}$  or  $20 \times 4.5 \text{ cm}$ .

### Assembly

1. The planking is to be fixed to the beams at each intersection point using nails or screws.

(Fig. A2.01)

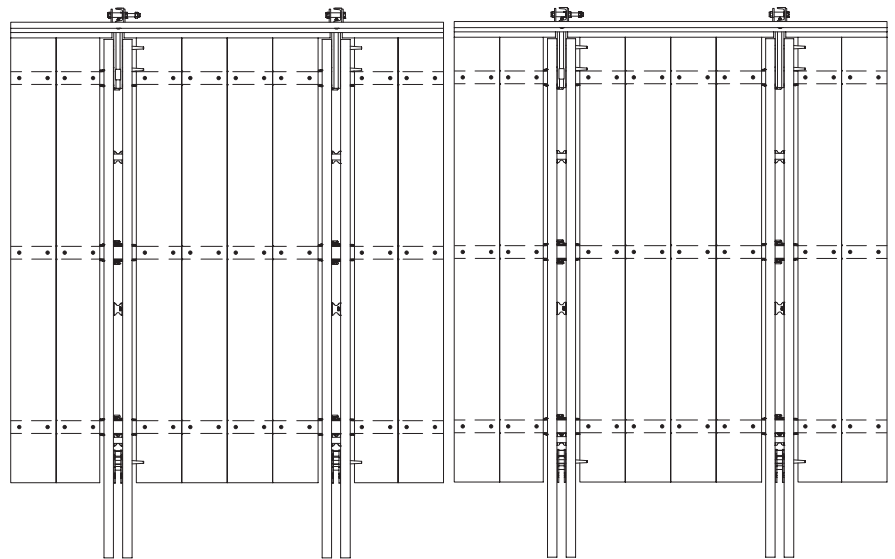

Fig. A2.01

## Guardrails



- For guardrails, use the dimensions specified in EN 12811.
- Fit guardrails onto all building edges.
- Fasten guardrails and toe boards to guardrail posts at every intersection point using nails or screws.
- The Guardrail Post GKB or Post PP can be used for the guardrails on the bridge structure.

## Variant for full enclosure



The full enclosure variant results in increased areas exposed to the wind and must be taken into consideration in the project-related static. (Fig. A2.02)

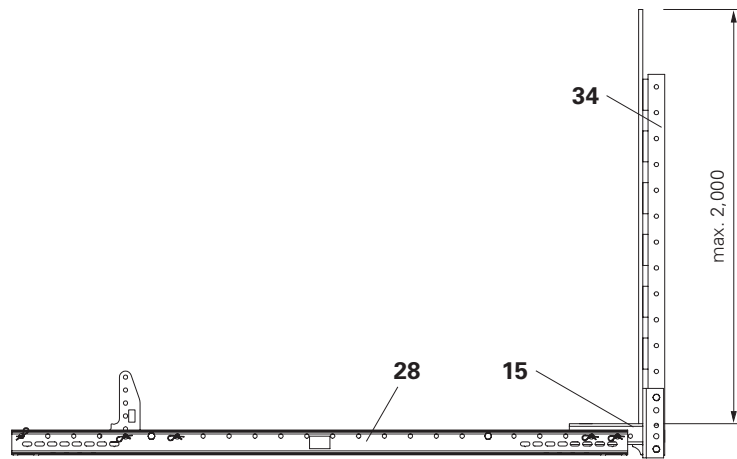

Fig. A2.02

## Variant 1: Guardrail Post GKB



### Danger

Unsecured concrete edge!

A fall can result in serious injuries or even death.

- ⇒ Assembly and dismantling should take place from a safe and secure working area, e.g. lifting platform, or
- ⇒ Use PPE.



- All loads that arise must be safely transferred.
- Reinforcement stirrups must have sufficient load-bearing capacity.

The Guardrail Post GKB is to be used in accordance with EN 13374 for temporary fall protection on bridge edges. (Fig. A2.03)

Install side guardrails in accordance with Tab. A2.01 or Tab. A2.02.

Two fastening variants are available:

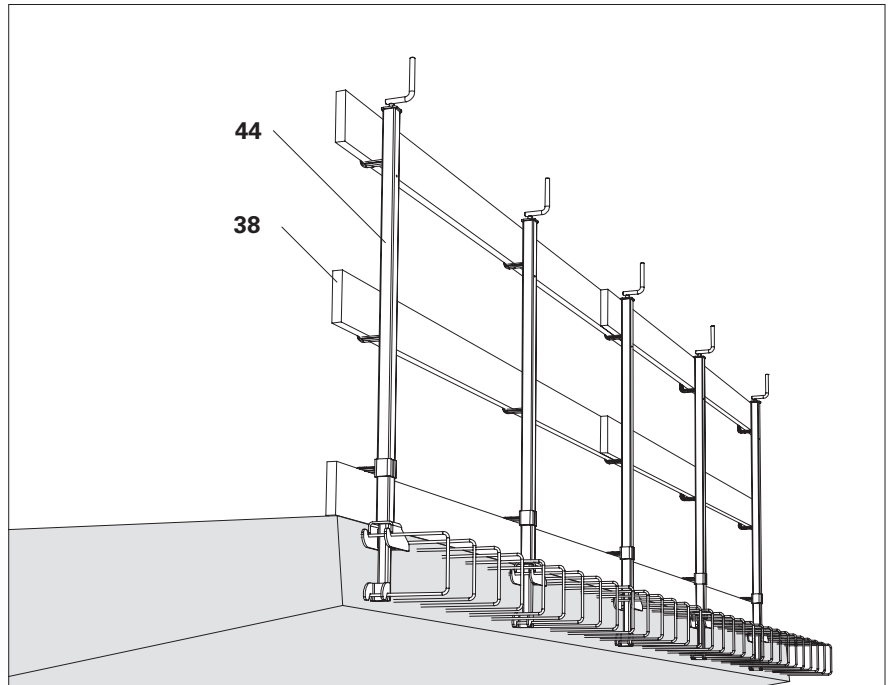

Fig. A2.03

### Permissible width of influence for the guardrail posts

Handrail board h/b [cm]	perm. width of influence e* [m]
12/4	1.60
15/3	1.55

\* Values are valid only in compliance with the boundary conditions in Tab. A2.02 and Fig. A2.04

Tab. A2.01

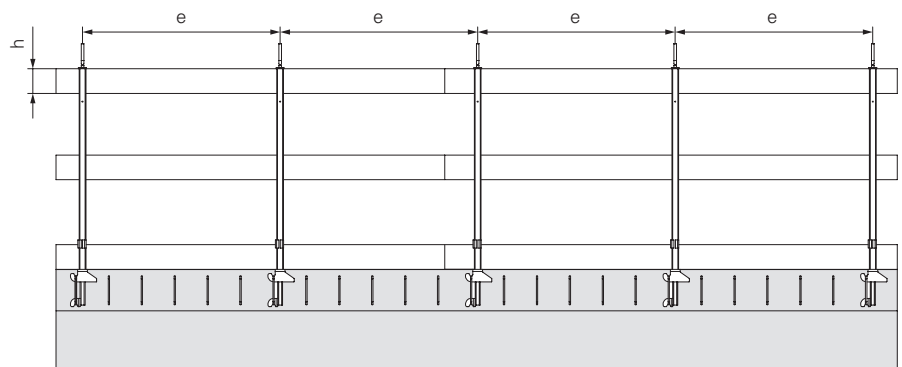

Fig. A2.04

The Guardrail Post GKB (**44**) is clamped in the reinforcement stirrup. (Fig. A2.05 + A2.06)

### Required components

<b>38</b> Guardrail boards	3x
<b>44</b> Guardrail Post GKB	2x

### Assembly

1. Pre-adjust Guardrail Post GKB (**44**) with the crank.
2. Place the Guardrail Post GKB (**44**) in the reinforcement stirrup and tension with the crank.
3. Position guardrail boards (**38**) and secure, e.g. by means of wire pins or wood screws. (Fig. A2.05 + A2.06)

### Dismantling

1. Turn crank until the lower holder is free and the guardrail post can be removed from the top reinforcement.

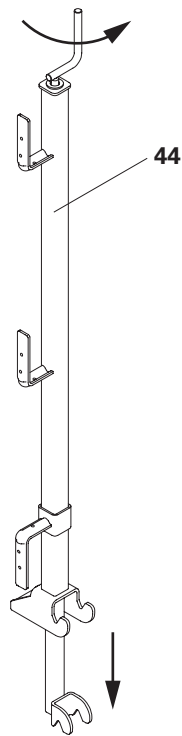

Fig. A2.05

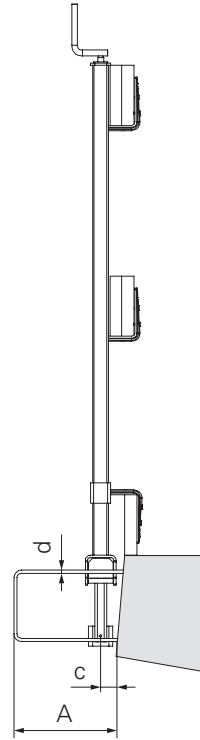

Fig. A2.06

Boundary conditions	
Tightening torque with the crank	$\geq 60 \text{ Nm}$
Reinforcement stirrup spacing A	$\geq 15 \text{ cm}$
Reinforcement stirrup diameter d	$\geq 12 \text{ mm}$
Distance between axis/guardrail post and front side of concrete c	$\leq 6 \text{ cm}$

Tab. A2.02

## Variant 2: Post PP

The Post PP (48) is fastened to the cantilevered parapet/bridge. (Fig. A2.07 + A2.08 + A2.10)

### Required components

<b>48</b> Post PP	1x
<b>49</b> Slab Foot PDF	1x
<b>70</b> PERI Tie Bolt 14 x 150	1x

### Assembly

1. Screw the Slab Foot PDF (49) into the installation position with a PERI Tie Bolt 14 x 150 (70).
2. Slide the Post PP (48) all the way into the Slab Foot PDF (49) until the latch engages.
3. Position guardrail boards (38) and secure, e.g. by means of wire pins or wood screws. (Fig. A2.08 + A2.09)



- For information on fitting the PERI Tie Bolt 14 x 150, see the data sheet. (Fig. A2.11)
- Alternatively, it is also possible to use a PERI Screw-On Sleeve M16/164, ISO 4017 M16 x 130-8.8 bolt and ISO 7094 100 HV, A16 washer for installation. For installation of the Screw-On Sleeve PERI M16/164, see data sheet. (Fig. A2.12)

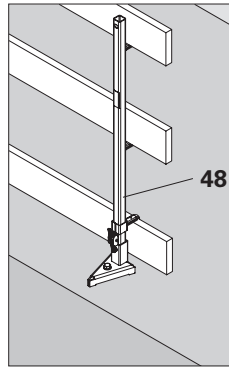

Fig. A2.07

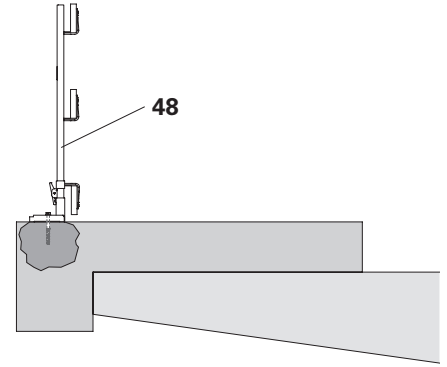

Fig. A2.08

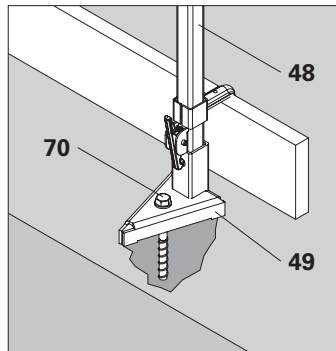

Fig. A2.09

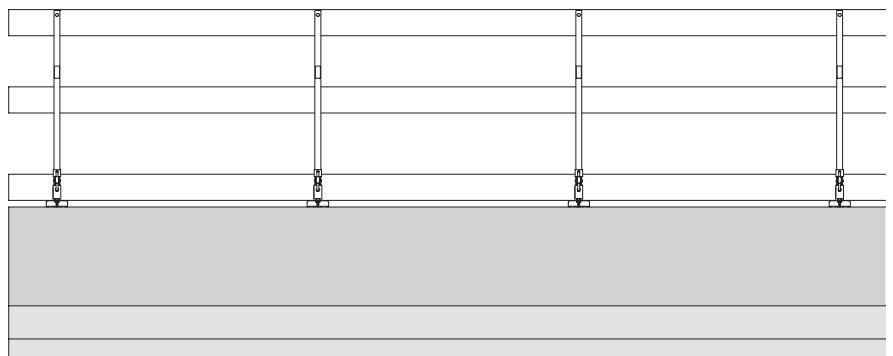

Fig. A2.10

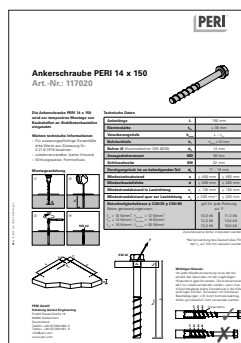

Fig. A2.11

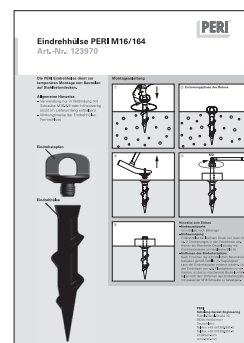

Fig. A2.12

## Permissible width of influence for the guardrail posts when using the PERI Screw-On Sleeve



- The forces shown in Tab. A2.03 can be linearly reduced or increased when using other anchoring methods with smaller or larger widths of influence.
- The permissible influence width in variant 2 is limited:
  - Handrail board h/b = 12 cm/4 cm: perm. influence width = 1.50 m
  - Handrail board h/b = 15 cm/3 cm: perm. influence width = 1.20 m
- For handrail boards that extend across only two bays, the permissible width of influence of the guardrail post is to be divided by 1.25.
- Safe transfer of forces into the structure must be guaranteed.
- Take into account the manufacturer's information on the selected anchoring.

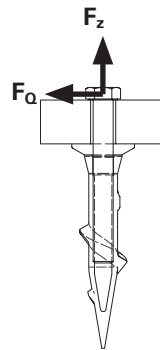

Fig. A2.13

Guardrail boards h/b [cm]	perm. width of influence* [m]	tensile force $F_Z$ on anchoring [kN]	shear force $F_Q$ on anchoring [kN]
12/4	1.20	9.89	0.53
15/3	0.95	9.74	0.53

\* Values are valid only in compliance with the boundary conditions in Tab. A2.04

Tab. A2.03

Boundary conditions	
Tightening torque with the crank	$\geq 60$ Nm
Reinforcement stirrup spacing A	$\geq 15$ cm
Reinforcement stirrup diameter d	$\geq 12$ mm
Distance between axis/guardrail post and front side of concrete c	$\leq 6$ cm

Tab. A2.04

## Spacers



- It may be necessary to fit additional M20-82 spacers (68) or M24-82 spacers (69) into the Climbing Rails RCS (1) or (14).
- It may be necessary to move or remove M20-82 spacers (68) or M24-82 spacers (68) in the Climbing Rails RCS (1) or (14).
- The fitting/movement procedure is only shown with one size for the purpose of providing an example.

### Fitting spacers

1. Position the tube sleeve of the spacer M20-82 (68.3) in the Climbing Rail RCS (1) with the help of a hammer.
2. Insert bolt ISO 4014 M20 x 120-8.8 (68.1) through the Climbing Rail RCS (1) and tube sleeve of the spacer M20-82 (68.3).
3. Fit nut ISO 7040 M20-8 (68.2) onto the bolt ISO 4014 M20 x 120-8.8 (68.1) and tighten.

(Fig. A3.01)

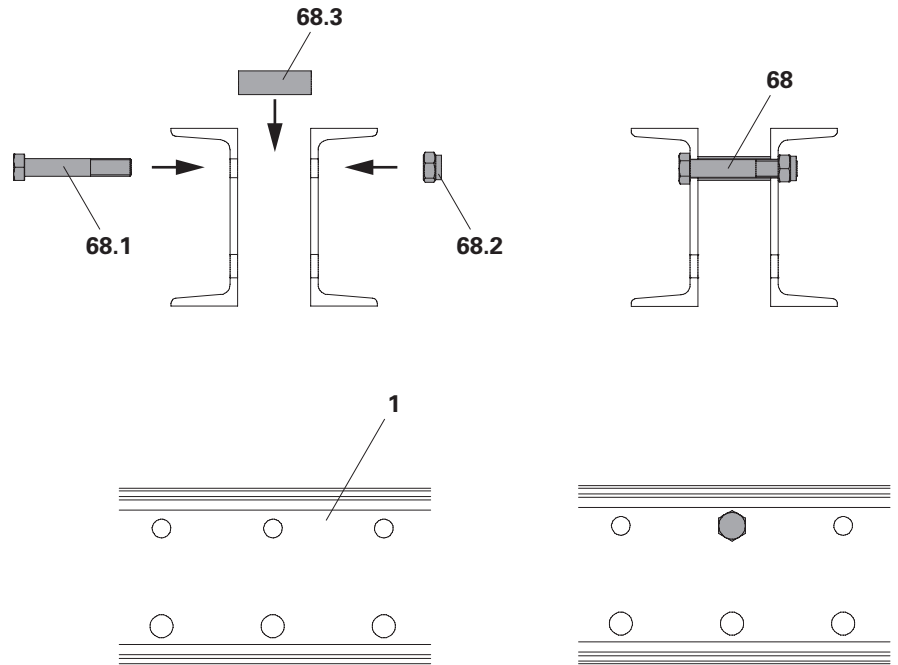

Fig. A3.01

### Moving spacers

1. Undo nut ISO 7040 M24-8 (69.2).
2. Remove the bolt ISO 4014 M24 x 130-8.8 (69.1).
3. Remove the tube sleeve of the spacer M24-82 (69.3).
4. Re-position the tube sleeve of the spacer M24-82 (69.3) at a hole with  $\varnothing 26$  with the help of a hammer.
5. Insert bolt ISO 4014 M20 x 130-8.8 (69.1) through the tube sleeve of the spacer M24-82 (69.3).
6. Fit nut ISO 7040 M24-8 (69.2) onto the bolt ISO 4014 M20 x 130-8.8 (69.1) and tighten.

(Fig. A3.02)

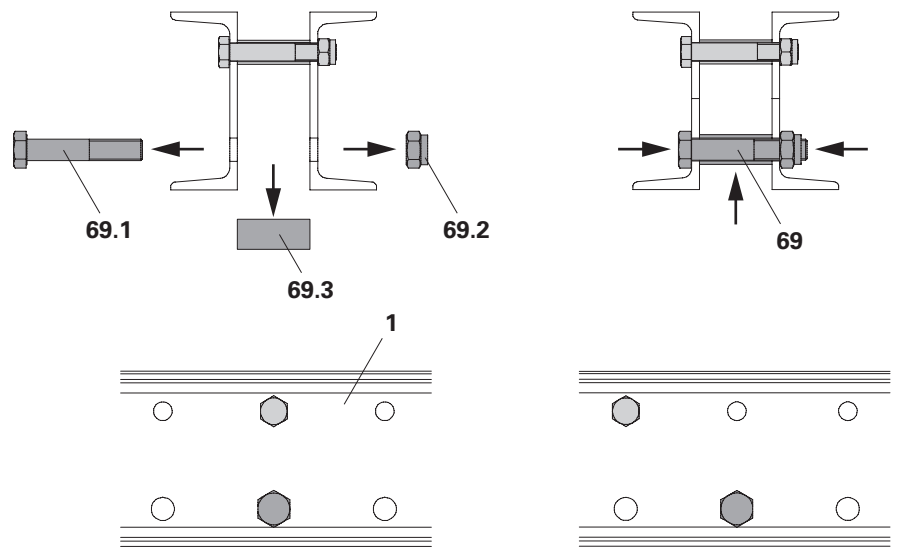

Fig. A3.02

## Preparing for assembly



- The project-related assembly plan from PERI is binding for assembly operations.
- Refer to the project-related assembly plan for the installation positions of the components.
- Prepare a level assembly surface with sufficient load-bearing capacity.
- A crane or other lifting device with a lifting capacity of at least 3.0 t is required for the assembly process.
- Lifting platforms or mobile scaffolds are recommended for the assembly process.
- Secure interim assembly states correctly by means of temporary supports in order to prevent any items from toppling over.
- Bolts that are fitted vertically should be screwed in from top to bottom.
- For bolts that are fitted horizontally, no fitting direction is prescribed. PERI recommends that you always fit the bolts in the same direction.
- All bolts must be secured using the appropriate cotter pins.



Reserve an adequate space for temporary storage of components and assemblies.

## Load-bearing capacity



Attach the climbing rails or assemblies to fitting pins or with lifting straps to the crane (Fig. B1.01).

### Load-bearing capacity of the load-bearing points:

- Fitting pin Ø 21 (**51**): 2,000 kg
- Fitting pin Ø 26 (**53**): 3,650 kg

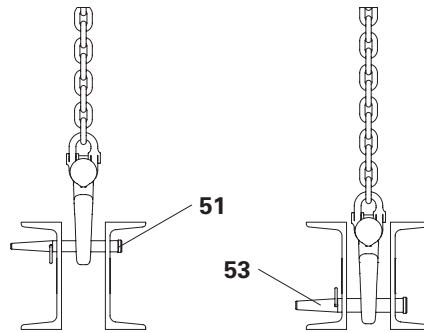

Fig. B1.01



- Observe the project-specific dead weight of the assemblies.
- Alternatively, load-bearing straps with the appropriate load capacity can be used.
- The attachment points are determined through a series of tests so that assemblies are in the correct position when they are transported with the crane.

## Safety instructions



### Danger

Heavy moving components can fall down or overturn!

During assembly, there is a risk of hands and other body parts being crushed.

- ⇒ Do not stand under suspended loads.
- ⇒ Use guide ropes when moving components.
- ⇒ Maintain an appropriate safety distance.
- ⇒ Do not stand between moving elements.



## Assembly using three assembly units

During pre-assembly, the three assemblies

- Travelling unit
- Kicker brace
- Concreting platform

are mounted individually and then assembled into a formwork carriage unit. (Fig. B1.02)

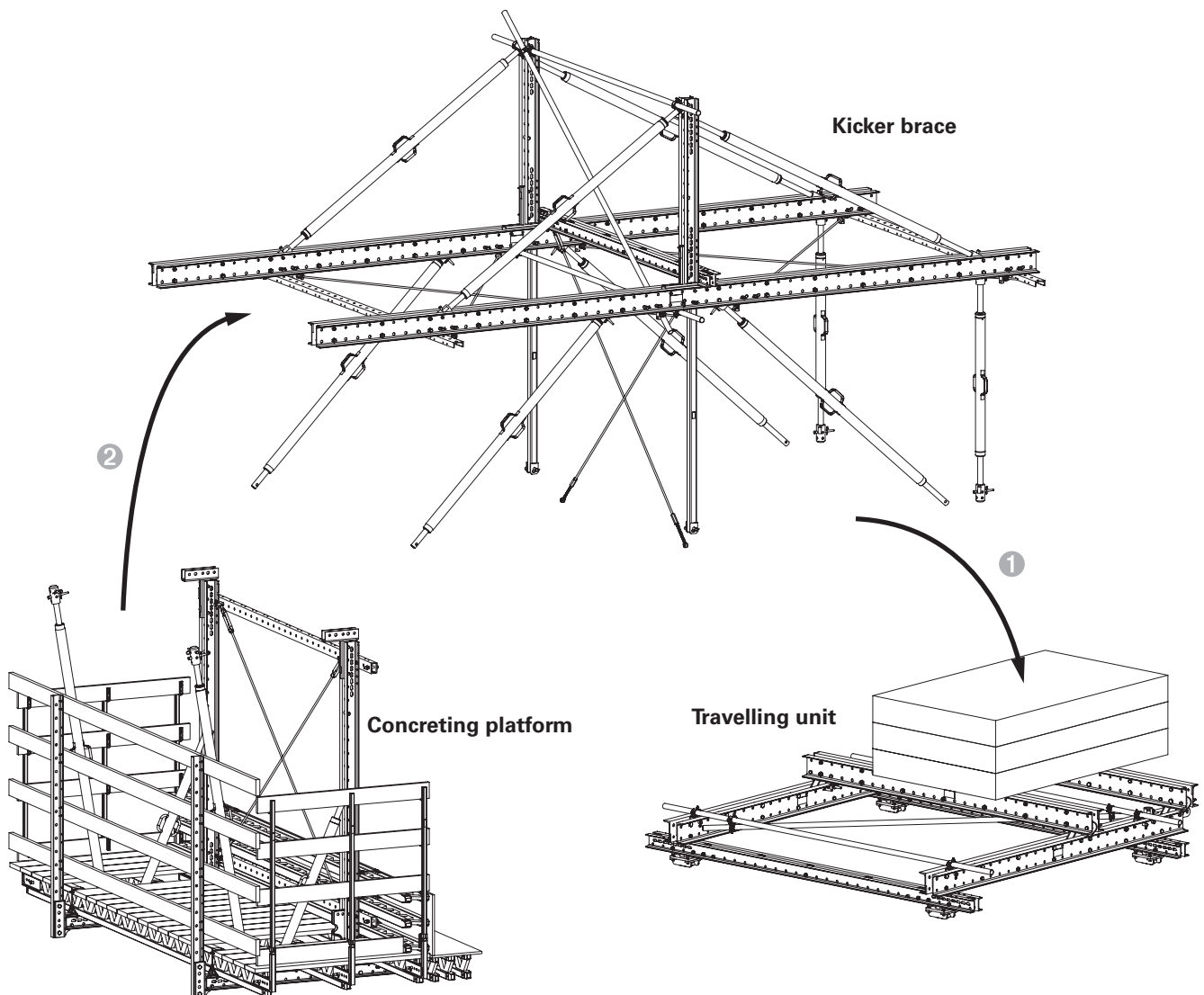

Fig. B1.02

The travelling unit consists of standardised PERI components. The project-specific assembly plan is binding for assembly operations.

## Fitting the heavy-duty roller gear

### Components

<b>2</b>	Heavy-Duty Roller Gear 150 kN, 4x series B-II	4x
<b>3</b>	Heavy-duty roller gear connection 4x VARIOKIT	4x
<b>6</b>	Steel Waler Universal SRU U120, L = 3.97 m	2x
<b>35</b>	Squared timber 14/14 cm	4x

### Assembly

1. Position two squared timbers (**35**) on the assembly area.
2. Place two Steel Waler Universal SRU (**6**) on the squared timbers.
3. Screw the Heavy-Duty Roller Gear 150 kN (**2**) onto the heavy-duty roller gear connection (**3**).
4. Screw the assembly onto Steel Waler SRU (**6**) with bolts M20 x 90 (**3.4**).
5. Position the Steel Waler SRU (**6**) on the squared timbers in parallel at the mounting distance. The rolling-contact bearings should be pointing downwards.

(Fig. B2.01 + B2.02)

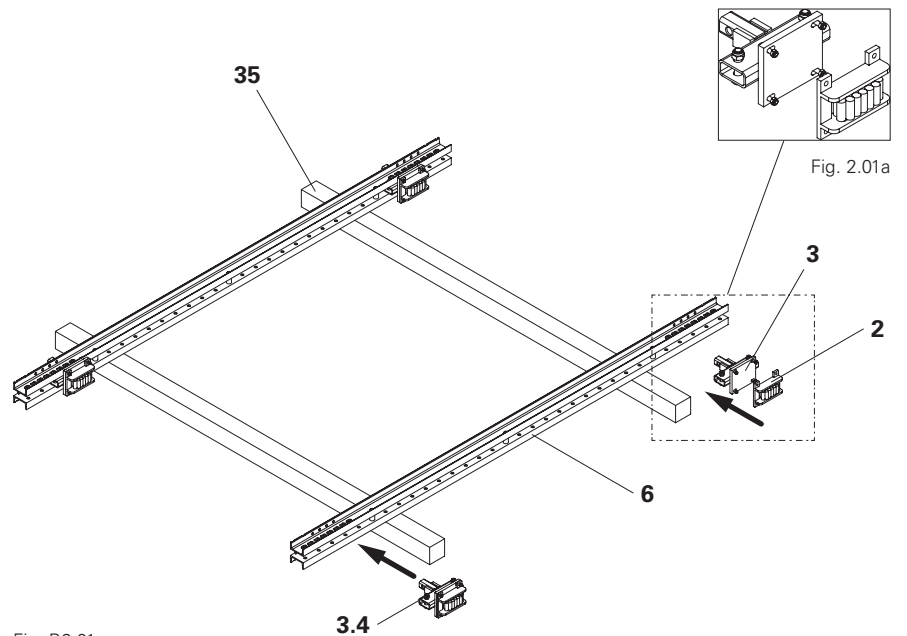

Fig. B2.01

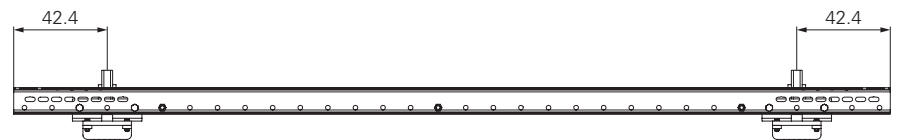

Fig. B2.02

## Fitting the carrier bar

### Components

<b>1</b> Climbing Rail RCS 348	2x
<b>51</b> Fitting pin $\varnothing$ 21 x 120	4x
<b>52</b> Cotter pin 4/1	4x

### Assembly

1. Attach the Climbing Rail RCS (**1a**) to the crane.
2. Position the Climbing Rail RCS (**1a**) above the Steel Waler SRU (**6**) and fit it into the square tube of the heavy-duty roller gear connection (**3**).
3. Fasten the Climbing Rail RCS (**1a**) with fitting pin  $\varnothing$  21 x 120 (**51**) and secure with cotter pin 4/1 (**52**).

(Fig. B2.03 + B2.04)



- Ensure that the installation position is correct. On the Climbing Rail RCS 348 (**1a**), the hole is  $\varnothing$  26 mm at the top.
- Remove the spacers before mounting the carrier bars.

(Fig. B2.05)



The fitting pin  $\varnothing$  21 x 120 (**51**) can be replaced with the bolt ISO 4014 M20 x 90-8.8. (Fig. B2.03)

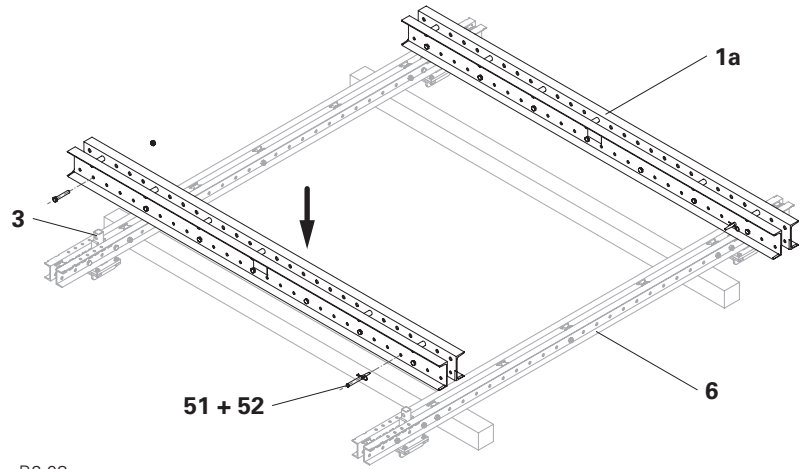

Fig. B2.03

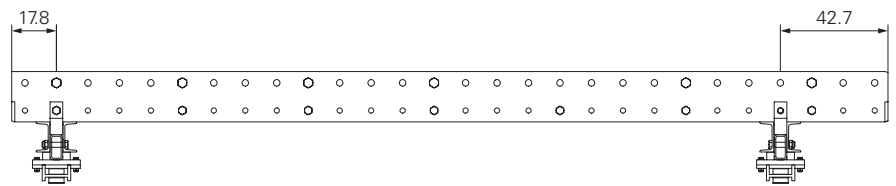

Fig. B2.04

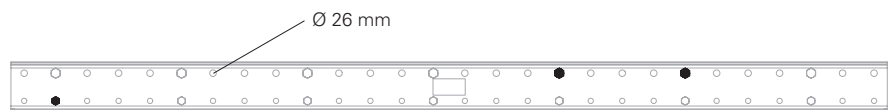

Fig. B2.05

## Fitting the ballast support

### Components

<b>1</b> Climbing Rail RCS 348	2x
<b>4</b> Cross Connector RCS	4x
<b>53</b> Fitting pin $\varnothing$ 26 x 120	16x
<b>54</b> Cotter pin 5/1	16x

### Assembly

1. Fasten the Cross Connector RCS (**4**) to the assembly position of Climbing Rail RCS (**1a**) with fitting pin  $\varnothing$  26 x 120 (**53**) and secure with cotter pin (**54**). (Fig. B2.06)
2. Attach the Climbing Rail RCS (**1b**) to the crane.
3. Position and fit the Climbing Rail RCS (**1b**) above the Cross Connector RCS (**4**).
4. Fasten the Climbing Rail RCS (**1b**) with fitting pin  $\varnothing$  26 x 120 (**53**) and secure with cotter pin 5/1 (**54**). (Fig. B2.07 + B2.08)



- Ensure that the installation position is correct. On the Climbing Rail RCS 348 (**1b**), the hole  $\varnothing$  21 mm is at the top.
  - Remove the spacers before mounting the ballast bars.
- (Fig. B2.09)

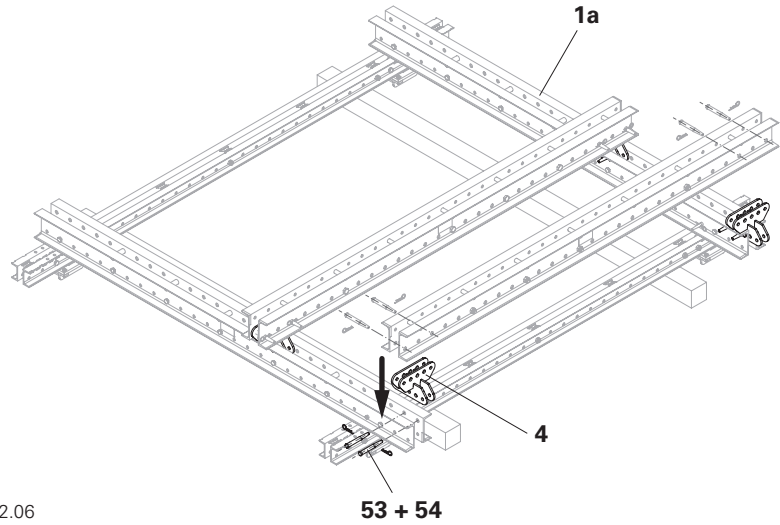

Fig. B2.06

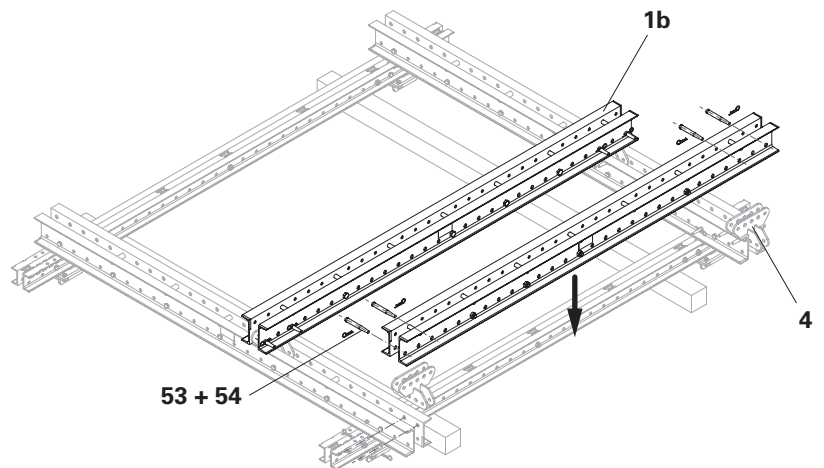

Fig. B2.07

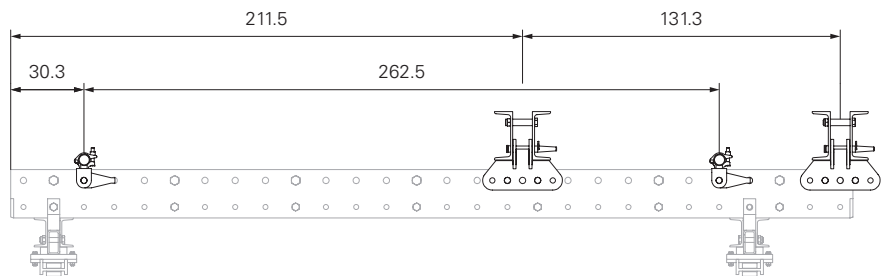

Fig. B2.08

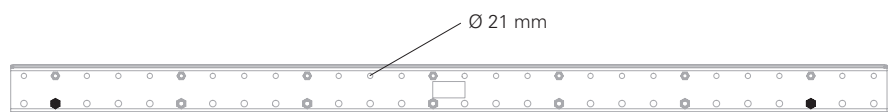

Fig. B2.09

## Fitting the bracing

### Components

<b>17</b> Scaffold Tube Holder RCS Ø 48	4x
<b>18</b> Swivel Coupling DK 48/48	2x
<b>25</b> Steel scaffolding tube Ø 48.3 x 3.2 Special length	3x

### Assembly

1. Fit the Scaffold Tube Holder RCS (**17**) into the assembly position in the Climbing Rail RCS (**1a**). Fasten it with bolt Ø 25 x 180 (**17.3**) and secure with cotter pin (**17.4**). The anti-rotation device (**17.2**) of the Scaffold Tube Holder RCS (**17**) points towards the centre of the Climbing Rail RCS (**1a**).
2. Insert the scaffolding tube (**25a**) through the screw-on couplings (**17.1**) and lock it in place. The projection is the same on both sides.
3. Lock one Swivel Coupling DK (**18**) into place on each scaffolding tube (**25a**) in a diagonally offset manner. The Swivel Coupling DK (**18**) points downwards.
4. Insert the scaffolding tube (**25b**) through the Swivel Coupling DK (**18**) and lock it in place. The projection is the same on both sides.

(Fig. B2.10)



Have the anti-rotation devices of the Scaffold Tube Holder RCS (**17**) engaged in the hole on the Climbing Rail RCS? (Fig. B2.10a)

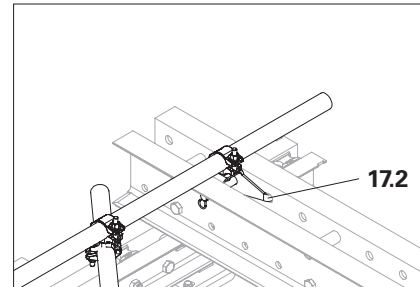

Fig. B2.10a

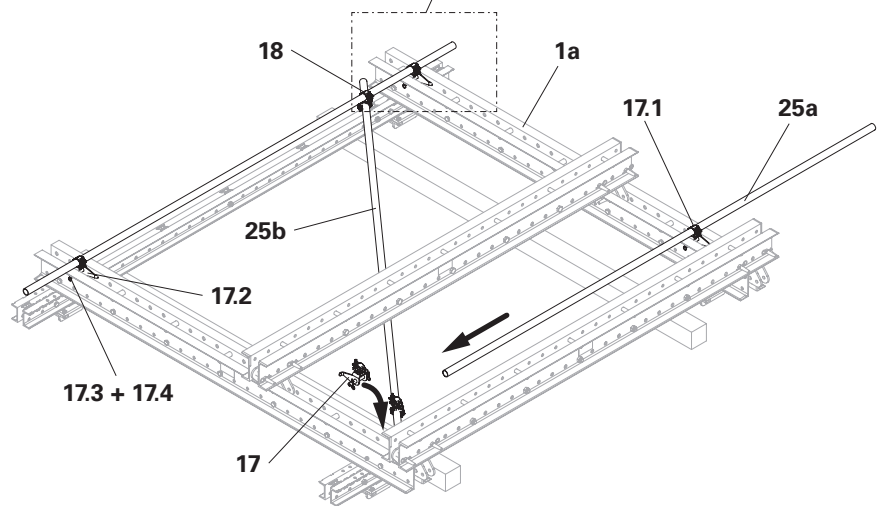

Fig. B2.10

## Fitting the kicker braces

### Components

<b>14</b> Climbing Rail RCS 748	2x
<b>23</b> Cross Connector VARIOKIT	2x
<b>35</b> Squared timber 14/14 cm	2x
<b>39</b> Handrail board 12/4 cm	4x
<b>51</b> Fitting pin $\varnothing$ 21 x 120	4x
<b>52</b> Cotter pin 4/1	4x
<b>72</b> Steel Waler Universal SRU U120, L = 3.47 m	1x

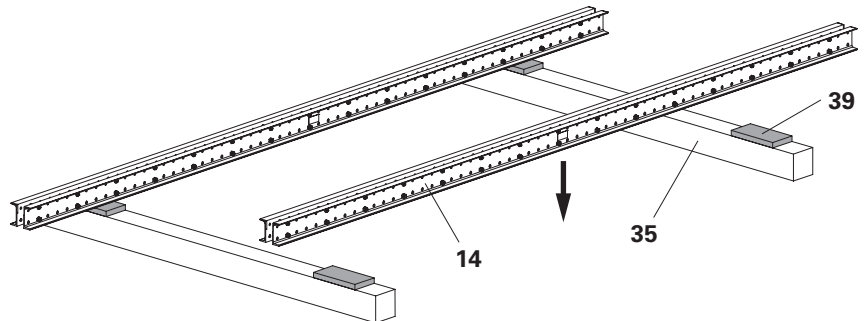

Fig. B3.01

### Installation position

On the Climbing Rail RCS 748 (**14**), the hole  $\varnothing$  21 mm is at the top. (Fig. B3.05)

### Assembly

1. Position two squared timbers 14/14 (**35**) on the assembly area.
2. Place Climbing Rail RCS 748 (**14**) on the squared timbers (**35**) and position to reflect the distance between the two kicker brace arms.

(Fig. B3.01)

3. Bolt the Cross Connector VARIOKIT (**23**) to the assembly position of the Steel Waler Universal SRU U120 (**72**) with fitting pin  $\varnothing$  21 x 120 (**51**) and secure with cotter pin 5/1 (**52**). The two extensions sit perpendicular to the Steel Waler SRU.

4. Fasten the Steel Waler Universal SRU U120 (**72**) to the assembly position of Climbing Rail RCS (**14**) with fitting pin  $\varnothing$  21 x 120 (**51**) and secure with cotter pin 4/1 (**52**).

(Fig. B3.02)

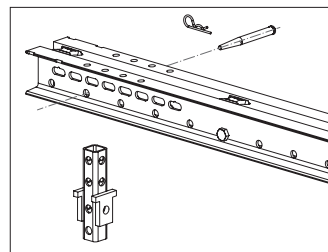

Fig. B3.02a

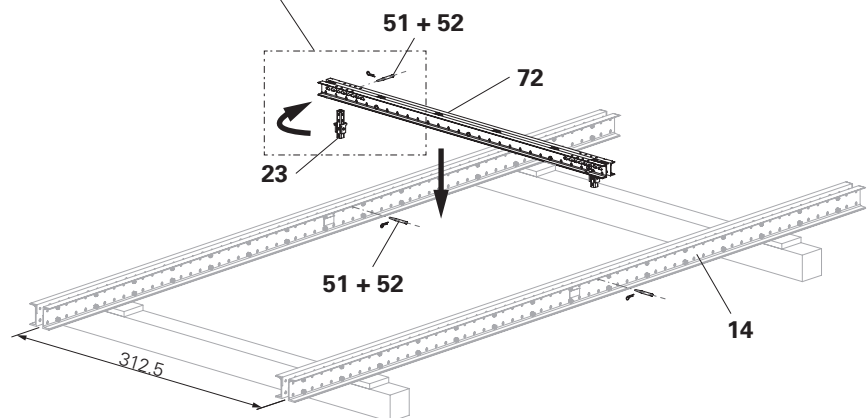

Fig. B3.02



Fasten short pieces of handrail board (**39**) to the squared timbers in the gap between the kicker brace arms. This facilitates the subsequent assembly of the bracing.

## Components

<b>19</b> Guardrail Post RCS 384	2x
<b>21</b> Bracing Connector RCS DW 15/M20	8x
<b>58</b> Bolt ISO 4014 M20 x 120-8.8	4x
<b>59</b> Nut ISO 7040 M20-8	4x

## Assembly

1. Fasten the Bracing Connector RCS DW 15/M20 (**21**) at the assembly position in the lower row of holes with the bolt (**21.1**) and secure with the cotter pin (**21.2**). The connection for the bracing points towards the centre of the beam.
  2. Screw the Guardrail Post RCS 384 (**19**) onto Bracing Connector RCS DW 15/M20 (**21**) with bolt M20 x 120 (**58**) and nut M20 (**59**). The projection is the same on both sides.
- (Fig. B3.03 + B3.04)



Remove the spacers before mounting the components. (Fig. B3.05)

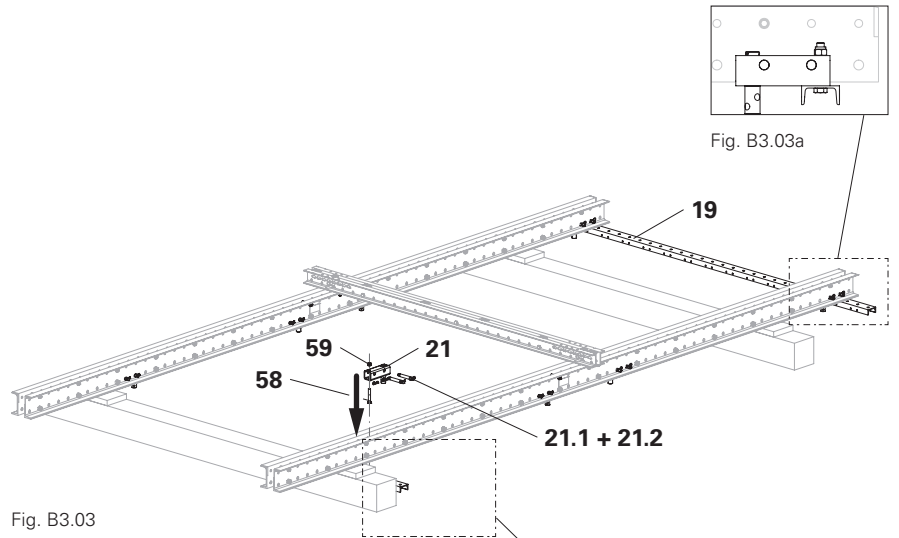

Fig. B3.03

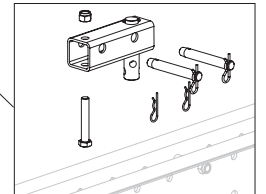

Fig. B3.03b

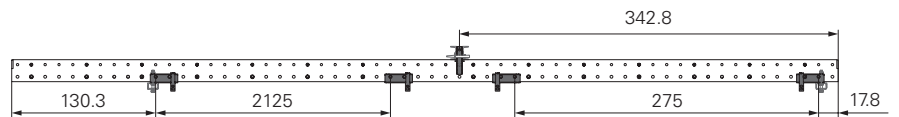

Fig. B3.04



Fig. B3.05

## Components

<b>12</b> Heavy-Duty Spindle SLS 260/360	4x
<b>13</b> Spindle Adapter SLS/RCS	4x
<b>15</b> Elbow Connection RCS/SRU	2x
<b>16</b> Steel Waler Universal SRU U120, L = 1.72 m	2x
<b>51</b> Fitting pin $\varnothing$ 21 x 120	16x
<b>52</b> Cotter pin 4/1	16x

## Assembly

1. Fasten the Elbow Connection RCS/SRU (**15**) to the mounting position with fitting pin  $\varnothing$  21 x 120 (**51**) and secure with cotter pin (**52**).

2. Fasten the Steel Waler Universal SRU U120 (**16**) to the Elbow Connection RCS/SRU (**15**) with fitting pin  $\varnothing$  21 x 120 (**51**) and secure with cotter pin (**52**).

(Fig. B3.06 + B3.08)

3. Fasten the Heavy-Duty Spindle SLS 260/360 (**12**) to the top of Steel Waler Universal SRU U120 (**16**) with fitting pin  $\varnothing$  21 x 120 (**51**) and secure with cotter pin (**52**).

4. Slip Spindle Adapter SLS/RCS (**13**) onto the other end of the Heavy-Duty Spindle SLS (**12**). Fasten it with fitting pin  $\varnothing$  21 x 120 (**51**) and secure with cotter pin (**52**).

5. Fasten the Spindle Adapter SLS/RCS (**13**) to the Climbing Rail RCS (**14**) with fitting pin  $\varnothing$  21 x 120 (**51**) and secure with cotter pin (**52**).

(Fig. B3.07 + B3.08)

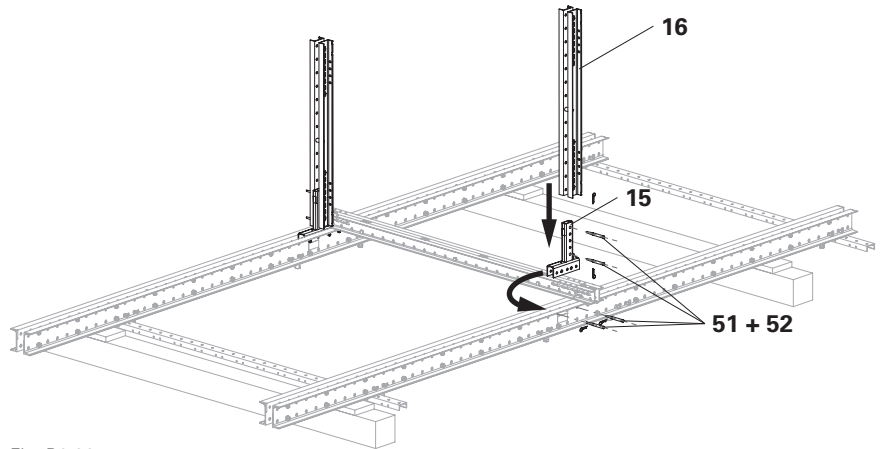

Fig. B3.06

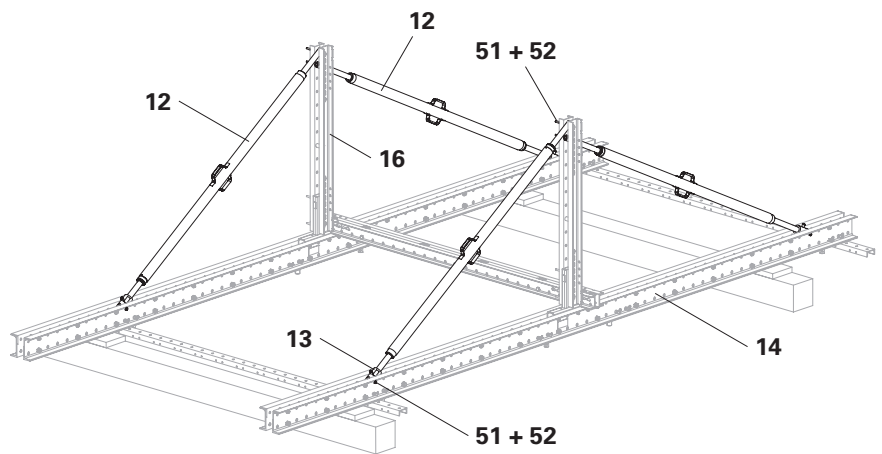

Fig. B3.07

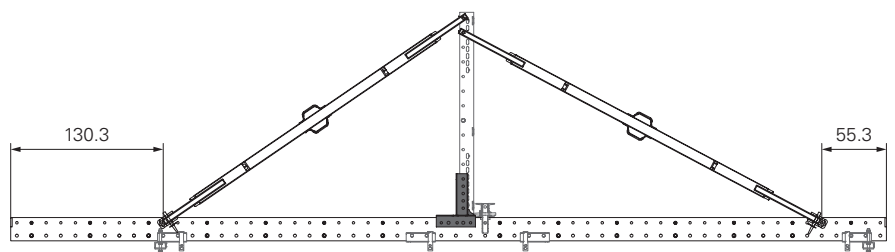

Fig. B3.08



## Fitting the bracing

### Components

<b>17</b>	Scaffold Tube Holder RCS Ø 48	2x
<b>18</b>	Swivel Coupling DK 48/48	4x
<b>25</b>	Steel scaffolding tube Ø 48.3 x 3.2	3x Special length

### Fitting scaffolding tubes

1. Fasten Swivel Coupling DK (**18a**) to the top end of the Heavy-Duty Spindle SLS (**12**).
  2. Insert the scaffolding tube (**25a**) through the swivel coupling (**18a**) and lock it in place. The projection is the same on both sides.
  3. Fasten a Swivel Coupling DK (**18b**) to the scaffolding tube (**25a**).
  4. Fit the Scaffold Tube Holder RCS (**17**) into the assembly position in the Climbing Rail RCS (**14**). Fasten it with bolt Ø 25 x 180 and secure with cotter pin.
  5. Insert the scaffolding tube (**25b**) through the Scaffold Tube Holder RCS (**17**) and lock it in place. The projection is the same on both sides.
  6. Fasten a Swivel Coupling DK (**18c**) to the scaffolding tube (**25b**).
  7. Insert the scaffolding tube (**25c**) through the Swivel Coupling DK (**18b + c**) and lock it in place. The projection is the same on both sides.
- (Fig. B3.09)

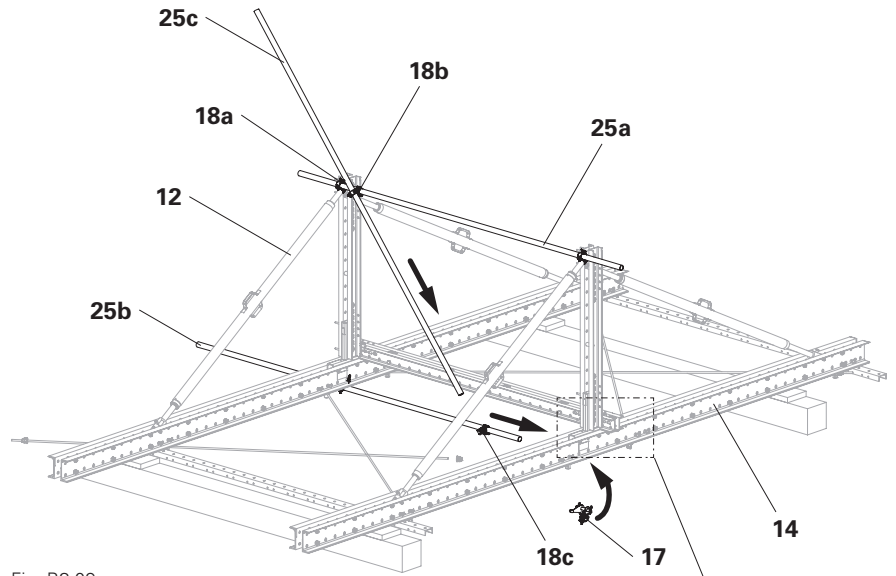

Fig. B3.09

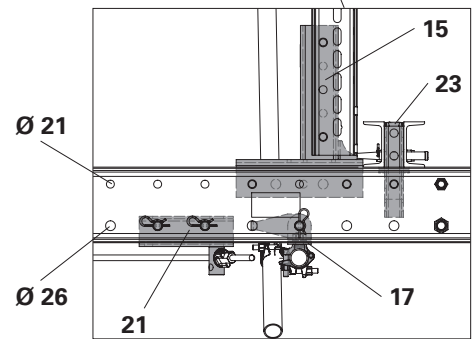

Fig. B3.09a



Have the flanges of the Scaffold Tube Holder RCS (**17**) engaged in the hole on the Climbing Rail RCS?

## Components

<b>22</b> Cam Nut DW 15	8x
<b>24</b> DW 15 tie rod Special length	4x

## Fitting tie rods

1. Slip the Tie Rods DW 15 (**24**) into Bracing Connectors RCS DW 15/M20 (**21**) in a diagonally opposite sequence.
  2. Attach the Cam Nuts DW 15 (**22**), but do not tension them yet.
- (Fig. B3.10)

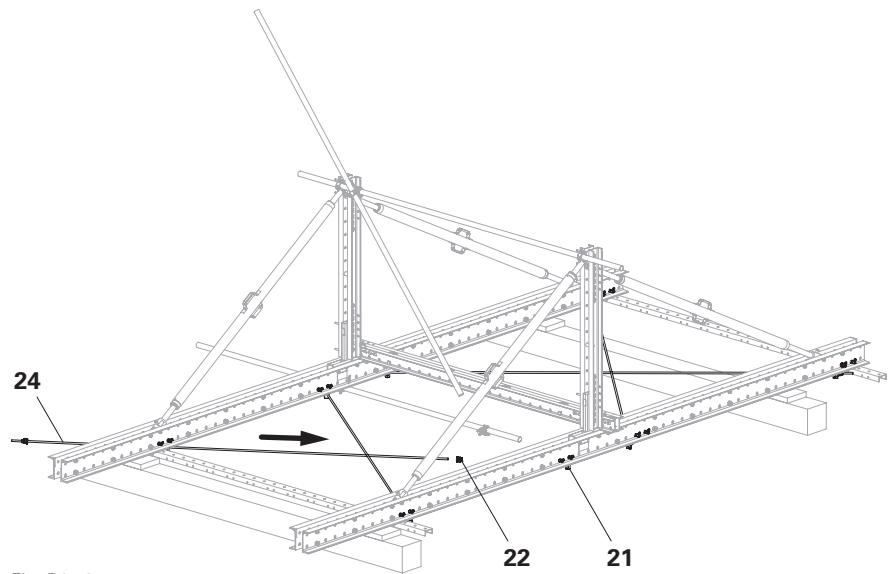

Fig. B3.10

The Cantilevered Parapet Carriage consists of a leading platform and a finishing platform. There are several standard platforms in between.

The assembly instructions describe how to erect the standard platforms and additionally and/or in deviation thereof how to erect the leading and finishing platforms.

## Slab formwork

The procedure for assembling the slab formwork for the standard, leading and finishing platforms is the same.

### Components

<b>15</b> Elbow Connection RCS/SRU	2x
<b>28</b> Steel Waler Universal SRU U120, L = 2.22 m	2x
<b>30</b> Hook Strap Uni HBU 24-28	12x
<b>31</b> Formwork Girder GT 24 L = 5.40 m	6x
<b>34</b> Guardrail Post RCS 226	2x
<b>35</b> Squared timber 14/14 cm	2x
<b>38</b> Handrail board 15/3 cm	4x
<b>51</b> Fitting pin Ø 21 x 120	4x
<b>52</b> Cotter pin 4/1	4x
<b>60</b> FI-Rd bolt M8 x 70-8.8	
<b>61</b> Nut ISO 7040 M8-8	

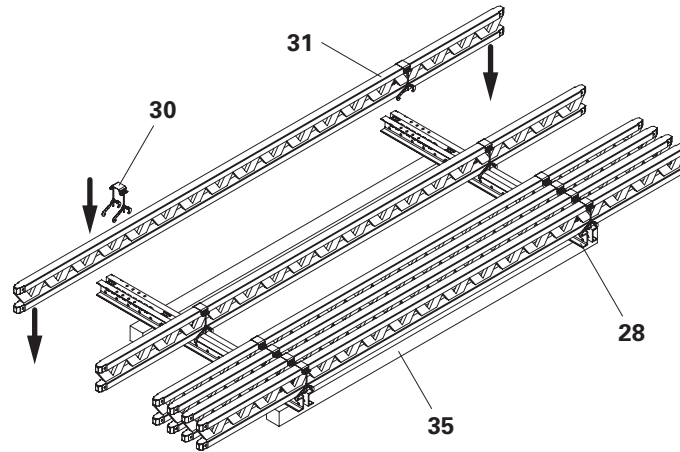

Fig. B4.01

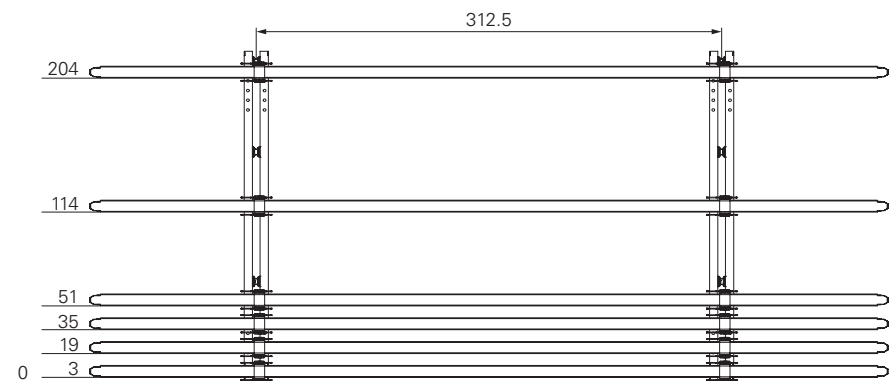

Fig. B4.02

### Assembling formwork girders and guardrails

1. Lay squared timbers (**35**) on the assembly area and put two Steel Walers Universal SRU (**28**) in position.
  2. Fasten Formwork Girders GT 24 (**31**) to the Steel Walers Universal SRU (**28**) with Hook Straps Uni HBU (**30**).
- (Fig. B4.01 + B4.02)

3. Fasten Elbow Connections RCS/SRU (15) to the Steel Walers Universal SRU (28) with two fitting pins  $\varnothing 21 \times 120$  (51) and secure with cotter pins (52).
  4. Screw Guardrail Posts RCS 226 (34) tightly onto the Elbow Connections RCS/SRU (15).
  5. Screw handrail boards (38) onto the Guardrail Posts RCS (34) with round head bolts M8 x 70 (60) and nuts M8 (61).
- (Fig. B4.03)

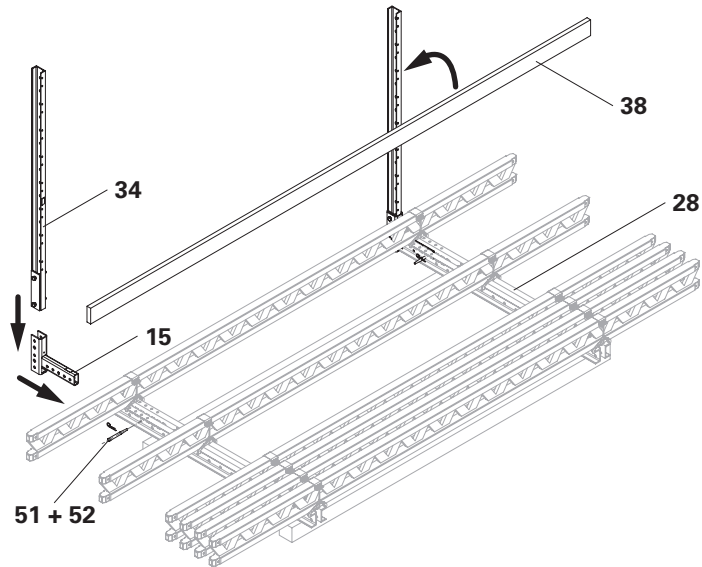

Fig. B4.03

## Components

- 36 Planking 24 x 4
- 40 Formlining

### Fitting the platform planking

1. Fasten the formlining (40) to the Formwork Girders GT 24 (31) with wood screws or wire nails.
2. Saw planking (36) to length and attach it to the Formwork Girders GT 24 (31) with wood screws or wire nails.

(Fig. B4.04)



- Only complete the planking above the Steel Walers SRU once the concreting platform has been attached.
- Alternatively, use 20 x 4.5 cm planking for the platform planking.

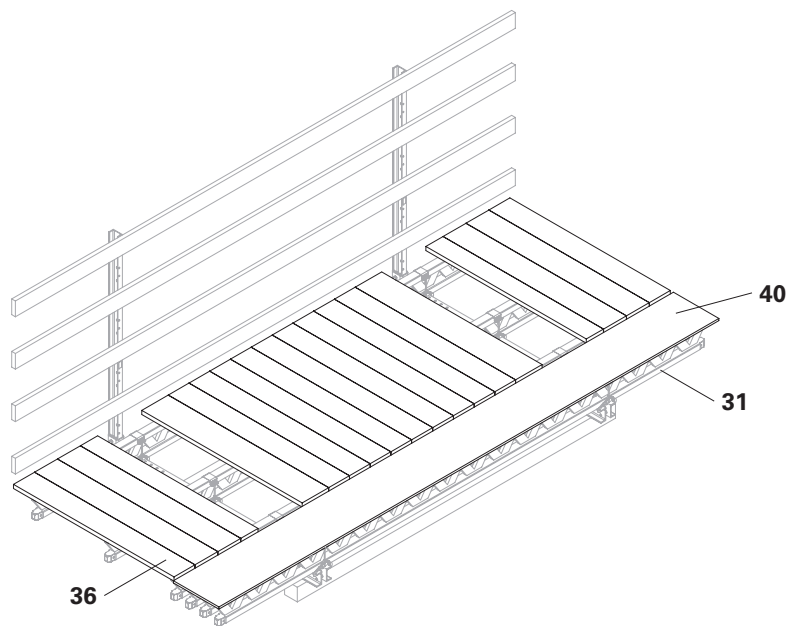

Fig. B4.04

## Front-mounted guardrails

Guardrails are fitted on the front side of the leading platform and finishing platform. The process for assembling the finishing platform is described below.

### Components

<b>32</b> Guardrail Holder GT 24/VT 20	3x
<b>33</b> Guardrail Post SGP	3x
<b>38</b> Handrail board 15/3 cm	4x
<b>51</b> Fitting pin Ø 21 x 120	3x
<b>52</b> Cotter pin 4/1	3x

### Fitting side guardrails

- Slide the Guardrail Holders GT 24/VT 20 (**32**) into the longitudinal girders of the Formwork Girders GT 24 (**31**). Fasten them with fitting pins Ø 21 x 120 (**51**) and secure with cotter pins 4/1 (**52**).

(Fig. B4.05)

- Insert the Guardrail Posts SGP (**33**) into the Guardrail Post Holders (**32**).
- Fasten the handrail boards (**38**) to the Guardrail Posts SGP (**33**) with wood screws or wire nails.

(Fig. B4.06)



Fit the Guardrail Post Holders GT 24/VT 20 (**32**) before fitting the platform planking.

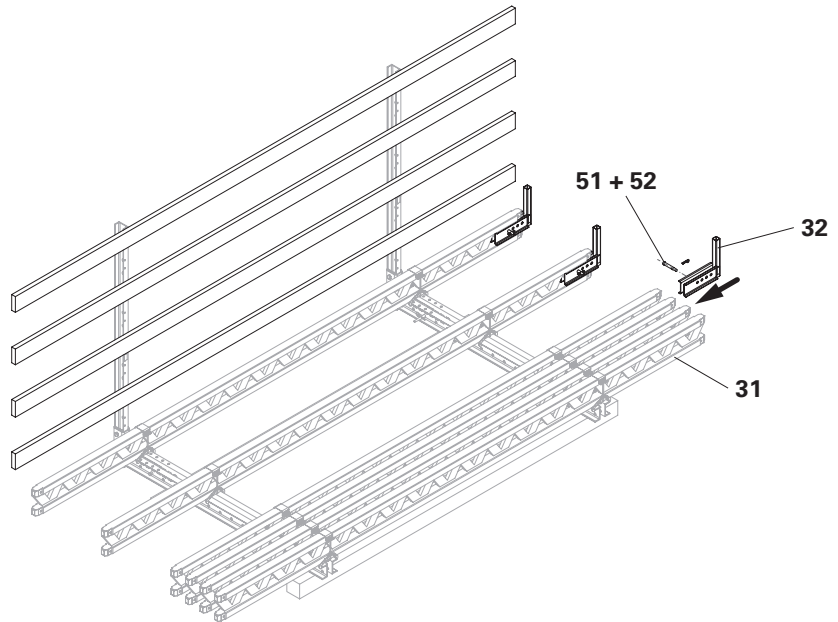

Fig. B4.05

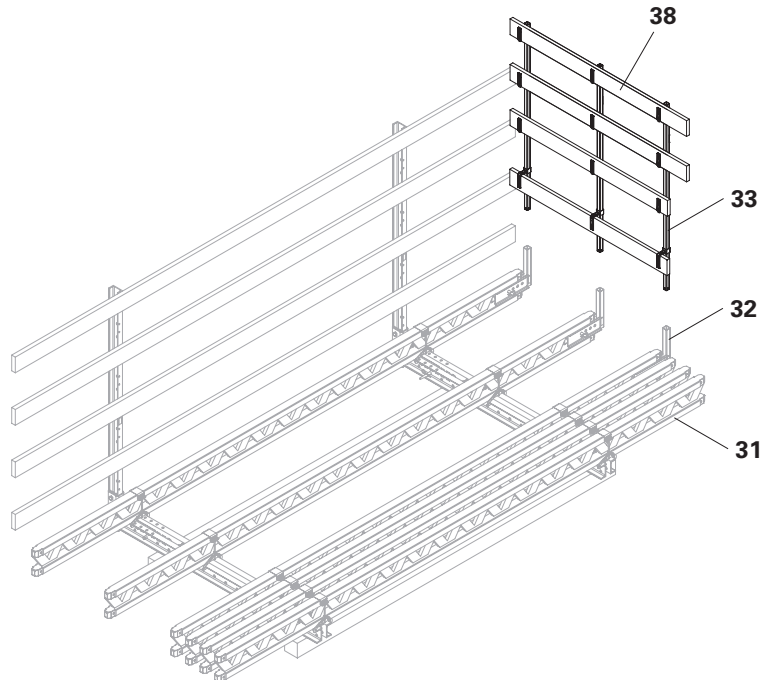

Fig. B4.06

## Side formwork on standard platforms

### Components

<b>15</b> Elbow Connection RCS/SRU	2x
<b>19</b> Guardrail Post RCS 384	2x
<b>20</b> Diagonal Bracing DW 15 ACS	2x
<b>24</b> Tie Rod DW 15 Special length	2x
<b>27</b> Steel Waler Universal SRU U120, L = 2.97 m	2x
<b>29</b> Universal Coupling UK 70	2x
<b>30</b> Hook Strap Uni HBU 24-28	6x
<b>31</b> Formwork Girder GT 24 L = 5.40 m	3x
<b>35</b> Squared timber 14/14 cm	
<b>51</b> Fitting pin Ø 21 x 120	8x
<b>52</b> Cotter pin 4/1	8x
<b>55</b> Bolt ISO 4017 M16 x 50-8.8	4x
<b>57</b> Nut ISO 7042 M16-8	4x

### Assembly

1. Lay squared timbers (**35**) on the assembly area and put two Steel Walers Universal SRU (**27**) in position.
2. Screw the Guardrail Posts RCS (**19**) onto the Steel Walers SRU (**27**) with bolts M16 x 50 (**55**) and nuts M16 (**57**).

(Fig. B4.07 + B4.09)

3. Fasten Elbow Connections RCS/SRU (**15**) to the Steel Walers Universal SRU (**27**) with two fitting pins Ø 21 x 120 (**51**) and secure with cotter pins (**52**).

4. Fasten Universal Couplings UK 70 (**29**) to the Steel Walers Universal SRU (**27**) with two fitting pins Ø 21 x 120 (**51**) and secure with cotter pins (**52**).

(Fig. B4.08)

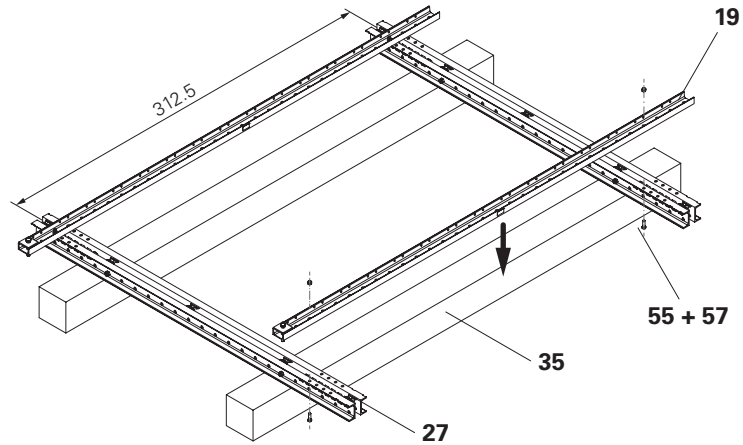

Fig. B4.07

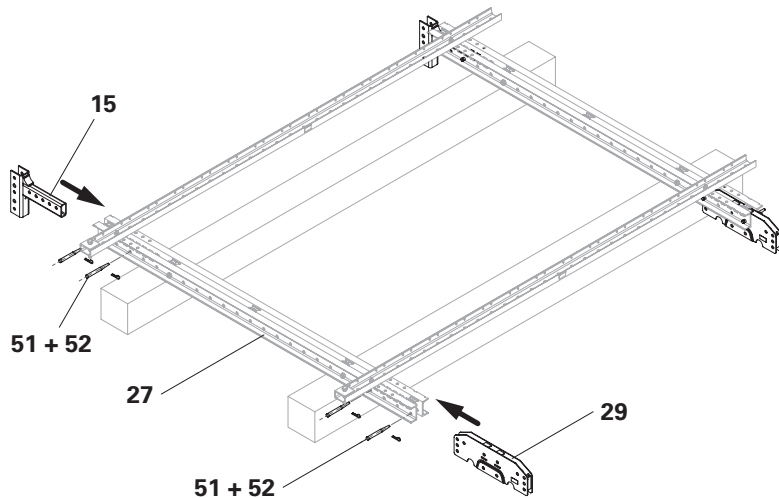

Fig. B4.08

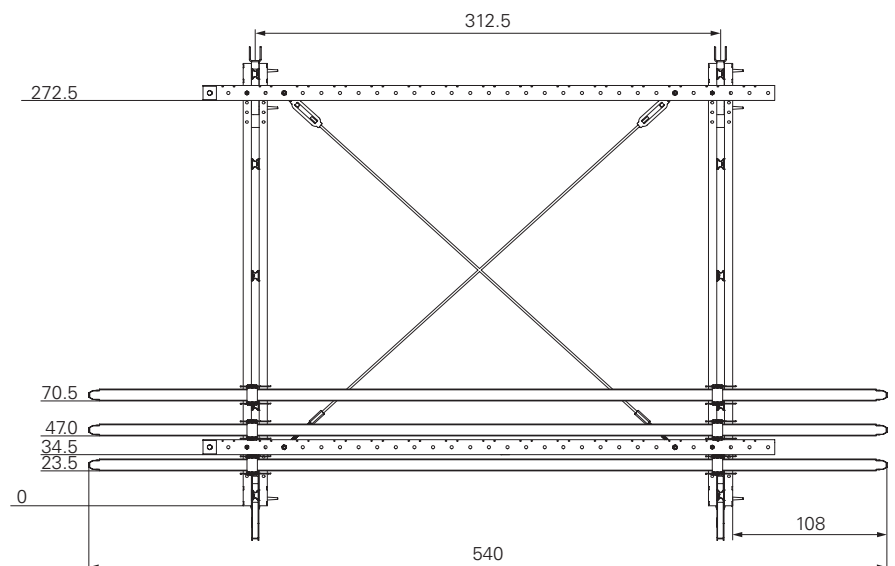

Fig. B4.09

## Preparing the diagonal bracing

1. Remove Tie Rod DW 15 (20.6) from Diagonal Bracing DW 15 ACS (20) and pack it away for transportation.
2. Loosen the lock nut (20.3) and screw it all the way back.
3. Turn the turnbuckle (20.1) up to the end of the thread on the eye bolt (20.2).
3. Screw Tie Rod DW 15, special length (24) into the hexagon nut (20.5) up to the stop.
4. Screw the turnbuckle (20.1) onto the Tie Rod DW 15, special length (24).

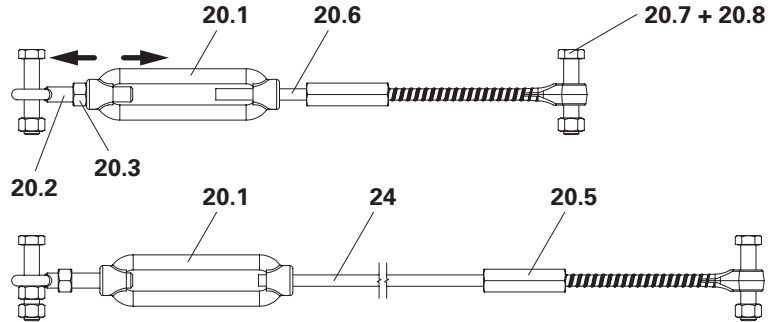

Fig. B4.10

## Fitting the diagonal bracing

1. Screw the diagonal bracing onto the guardrail posts (19) with bolts M20 x 100 (20.7) and nuts M20 (20.8) in a diagonally opposite sequence.
2. Calibrate the diagonal bracing and tension the diagonal struts with the turnbuckles (20.1).
3. Secure the turnbuckles (20.1) with lock nuts (20.3).

(Fig. B4.11)

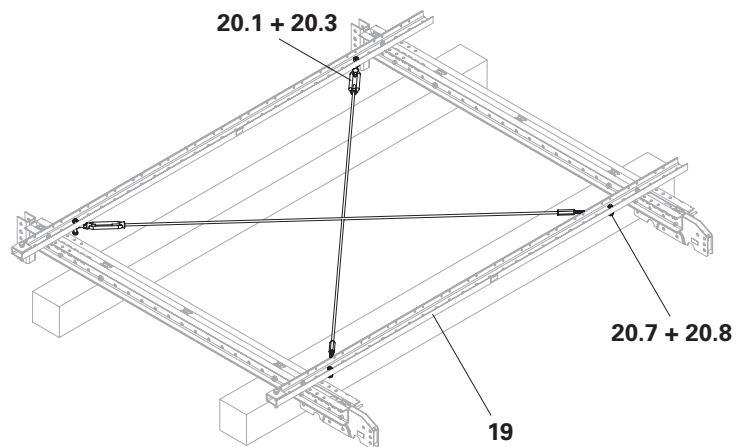

Fig. B4.11

## Fitting the formwork girders

1. Fasten Formwork Girders GT 24 (31) to the Steel Walers Universal SRU (27) with Hook Straps Uni HBU (30).

(Fig. B4.12)

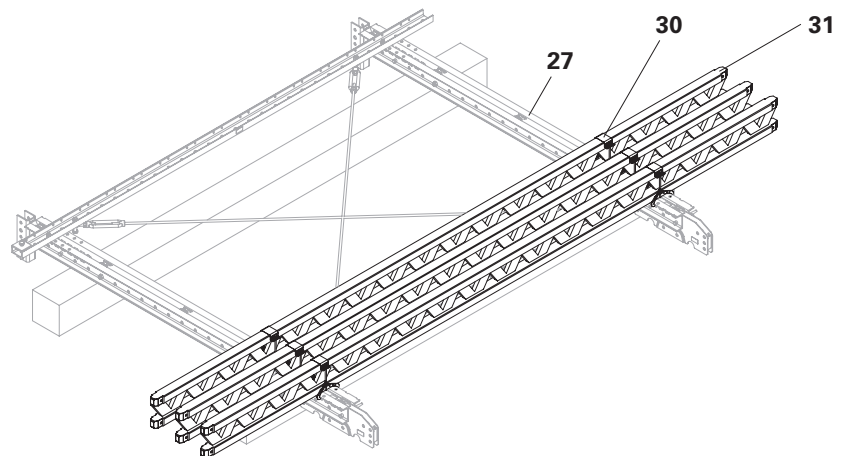

Fig. B4.12

## Side formwork on leading platform and finishing platform

The side formwork on the leading platform and finishing platform is shortened. As a result, the stopend formwork shifts inwards and the concreting platform is accessible from all sides.

The benefits of this are as follows:

- Unrestricted access to the concreting platform.
- Fitting the stopend formwork is a straightforward process.
- The concreting platform can be inclined to a greater extent.

The leading platform and finishing platform are set up as mirror images of each other. The assembly process is identical to that of the standard platform.

### Components

<b>15</b> Elbow Connection RCS/SRU	2x
<b>19</b> Guardrail Post RCS 384	2x
<b>20</b> Diagonal Bracing DW 15 ACS	2x
<b>24</b> Tie Rod DW 15 Special length	2x
<b>27</b> Steel Waler Universal SRU U120, L = 2.97 m	2x
<b>29</b> Universal Coupling UK 70	2x
<b>30</b> Hook Strap Uni HBU 24-28	6x
<b>31a</b> Formwork Girder GT 24 L = 4.80 m	3x
<b>35</b> Squared timber 14/14 cm	
<b>51</b> Fitting pin Ø 21 x 120	8x
<b>52</b> Cotter pin 4/1	8x
<b>55</b> Bolt ISO 4017 M16 x 50-8.8	4x
<b>57</b> Nut ISO 7042 M16-8	4x

### Assembly

1. See "Side formwork on standard platforms" on page 38 for information on assembly.

(Fig. B4.13)

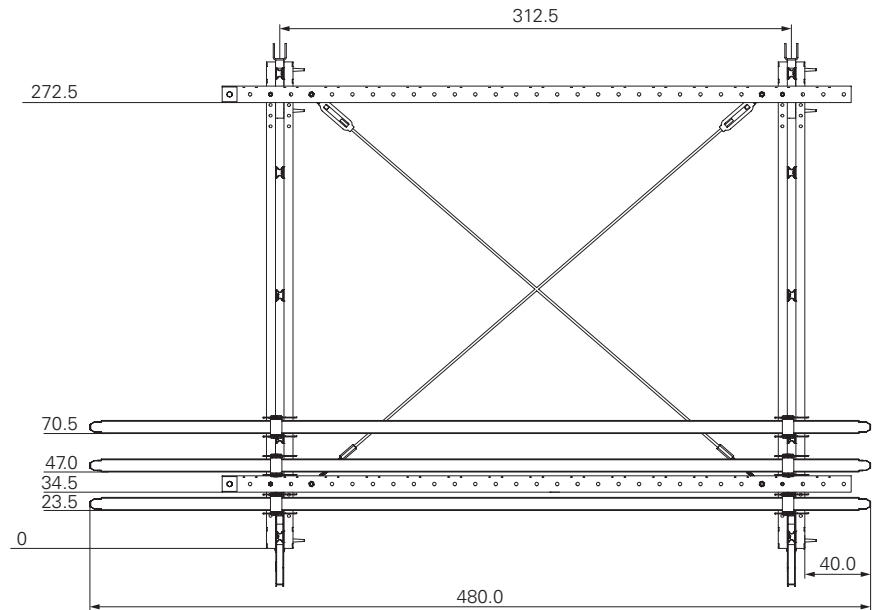

Fig. B4.13



## Completing the concreting platform



### Caution

- Heavy moving parts!  
During assembly, there is a risk of hands being trapped.  
⇒ Do not reach between the side formwork and slab formwork.
- Side formwork can tilt inwards!  
Crush hazard for arms, torso and head.  
⇒ Only release the side formwork from the crane when the heavy-duty spindles (10) have been fitted (Fig. B4.15).

### Components

<b>10</b> Heavy-Duty Spindle SLS 140/240	2x
<b>12</b> Heavy-Duty Spindle SLS 260/360	2x
<b>13</b> Spindle Adapter SLS/RCS	2x
<b>40</b> Formlining	
<b>41</b> Binding wire	
<b>51</b> Fitting pin Ø 21 x 120	10x
<b>52</b> Cotter pin 4/1	10x

### Assembly

1. Attach the crane lifting gear to the Elbow Connections RCS/SRU (15) of the side formwork with fitting pins Ø 21 x 120 (51) and secure with cotter pins 4/1 (52).
2. Position the side formwork above the slab formwork and slowly lower it.
3. Fit the Universal Couplings UK 70 (29) into the Steel Walers Universal SRU (28). Connect them with fitting pins Ø 21 x 120 (51) and secure with cotter pins 4/1 (52).

(Fig. B4.14 + B4.14a)

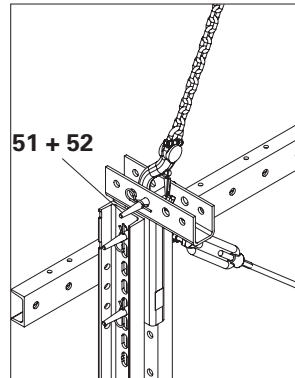

Fig. B4.14a

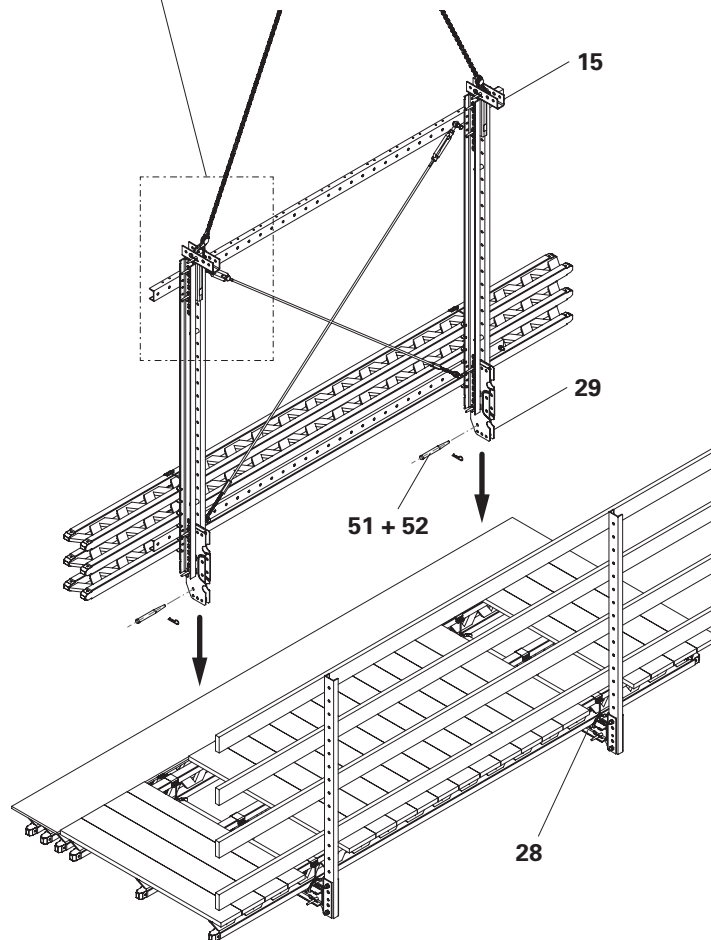

Fig. B4.14



## Caution

The heavy-duty spindle (12) may tilt forwards or backwards!  
Crush hazard for arms, torso and head.  
⇒ Lean the heavy-duty spindle (12) up against the guardrail and affix with binding wire.

4. Bolt the Heavy-Duty Spindles SLS (10) to the Steel Walers Universal SRU (27+28) of the slab formwork and side formwork with fitting pins  $\text{Ø } 21 \times 120$  (51) and secure with cotter pins 4/1 (52). The Heavy-Duty Spindles SLS (10) serve as temporary support.
5. Remove the crane lifting gear. (Fig. B4.15 + B4.17)
6. Connect the Heavy-Duty Spindles SLS (12) to the Steel Walers Universal SRU (28) of the slab formwork with fitting pins  $\text{Ø } 21 \times 120$  (51) and secure with cotter pins 4/1 (52).
7. Bind the Heavy-Duty Spindles SLS (12) tightly to the guardrails using binding wire (41) and secure them to prevent them from toppling over.
8. Fit Spindle Adapters SLS/RCS (13) onto the thread of the Heavy-Duty Spindles SLS (12). Connect them with fitting pins  $\text{Ø } 21 \times 120$  (13.1) and secure with cotter pins 4/1 (13.2).
9. Fasten the formlining (40) to the Formwork Girders GT 24 of the side formwork with wood screws or wire nails. (Fig. B4.16 + B4.17)

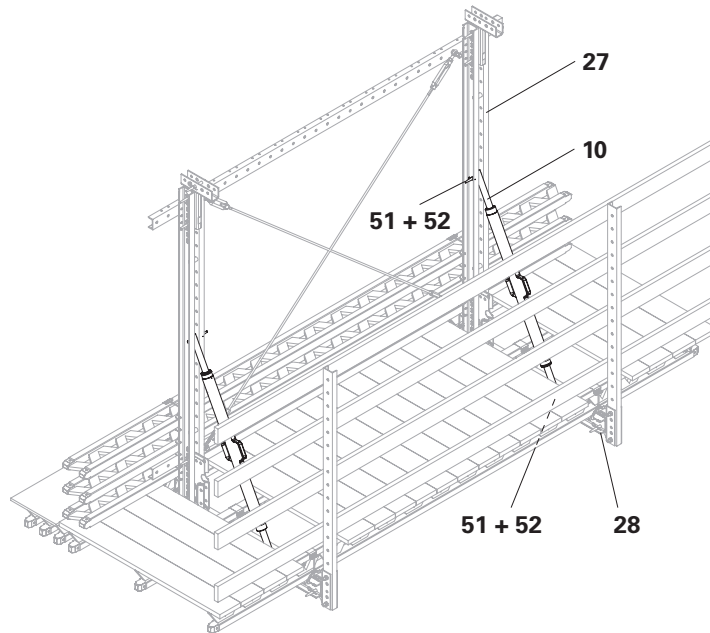

Fig. B4.15

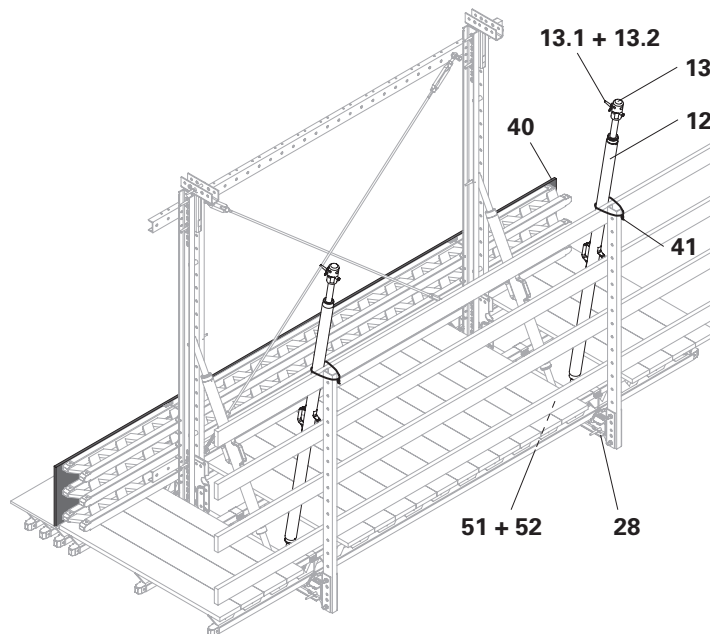

Fig. B4.16

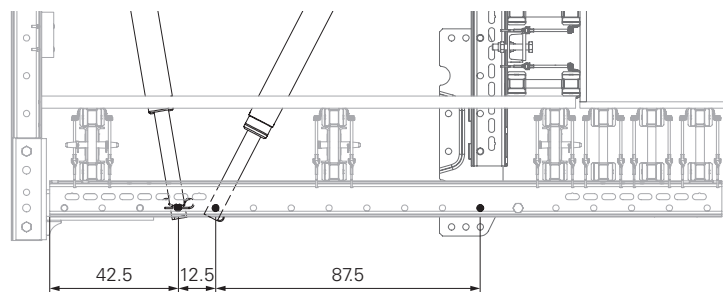

Fig. B4.17

## Arrangement of leading platform, standard platform and finishing platform



Ensure that the different concreting platforms are laid out correctly during the attachment process. (Fig. B4.18)

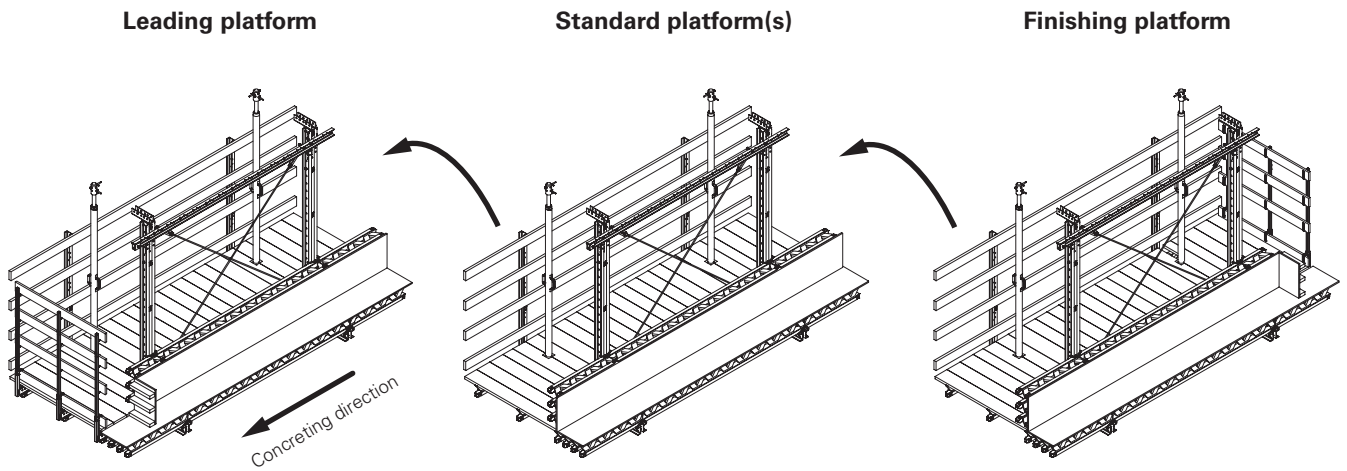

Fig. B4.18



- Make sure that guardrails are fitted onto all building edges in accordance with country-specific regulations.
- Observe the project-specific dead weight of the assemblies.
- The attachment points are determined through a series of tests so that assemblies are in the correct position when they are transported with the crane.

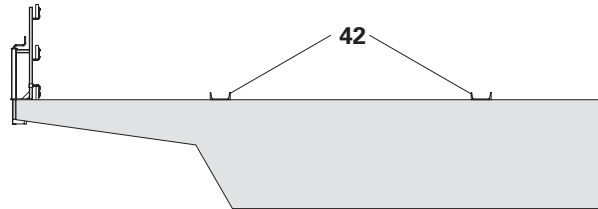

Fig. C1.01



U-sections and ballast are provided by the contractor. Crane ballast is one example of ballast that would be suitable.

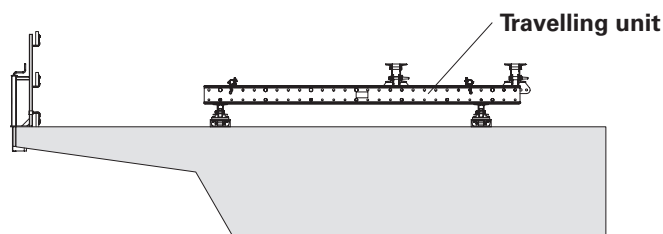

Fig. C1.02

## Components

- 26** Ballast
- 42** U-section

## Assembly

1. Set down and position the U-sections (**42**) and secure them to prevent them from slipping. (Fig. C1.01)
2. Attach the travelling unit to the crane and set it down in the U-sections. (Fig. C1.02)
3. Weigh the travelling unit down with ballast (**26**). (Fig. C1.03)

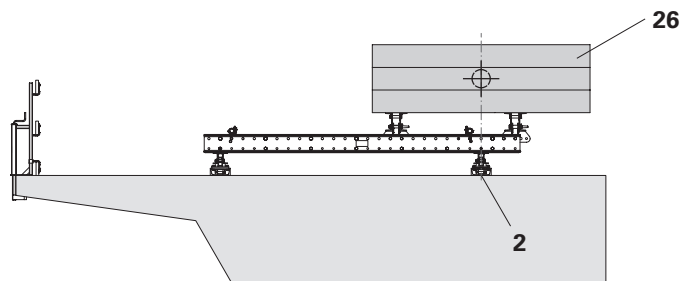

Fig. C1.03



- Make sure that the centre of gravity of the ballast (**26**) is positioned above the rear heavy duty roller gear (**2**). (Fig. C1.03)
- The approach to ballasting is dependent on the project.
- If the bridge is subject to a longitudinal inclination, anchor the travelling unit. See "Anchoring in the longitudinal direction" on page 50.

## Preparation



- Scaffold stands with sufficient load-bearing capacity are required for this assembly step.

## Components

<b>8</b> Diagonal Strut RCS 212	2x
<b>43</b> Scaffold stand	4x
<b>53</b> Fitting pin Ø 26 x 120	2x
<b>54</b> Cotter pin 5/1	2x

### Fitting the diagonal strut

1. Set up scaffold stands (**43**) at the assembly area. The working height should be approx. 1.5 m.
2. Attach the crane lifting gear to the spacers in Climbing Rail RCS 748 (**14**).
3. Set the kicker braces down on the scaffold stands.
4. Calibrate the diagonal bracing and tighten the cam nuts (**22**) of the horizontal bracing with an open-end wrench AF 27.

(Fig. C2.01)

5. Fasten the Diagonal Strut RCS (**8**) to the Climbing Rail RCS (**14**) with fitting pins Ø 26 x 120 (**53**) and secure with cotter pins (**54**).

(Fig. C2.02)

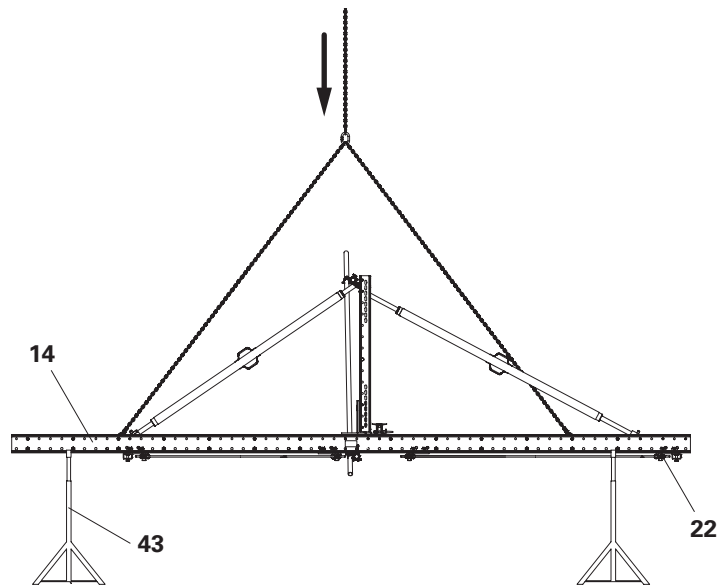

Fig. C2.01

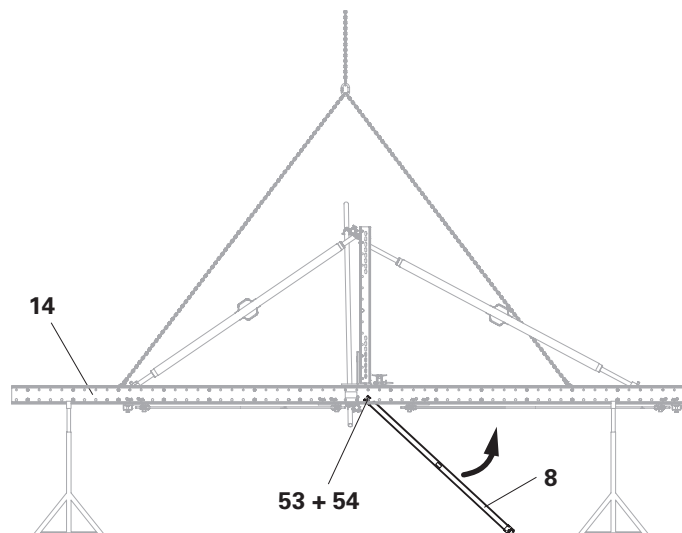

Fig. C2.02

## Components

<b>20</b> Diagonal Bracing DW 15 ACS	2x
<b>24</b> Tie Rod DW 15 Special length	2x
<b>51</b> Fitting pin Ø 21 x 120	2x
<b>52</b> Cotter pin 4/1	2x

### Fitting the Diagonal Bracing DW 15 ACS

1. See "Preparing the diagonal bracing" on page 39 for information on how to fit the Diagonal Bracing DW 15 (20).
2. Fasten the Diagonal Bracing DW 15 (20) to the Steel Waller SRU (6) with fitting pins Ø 21 x 120 (51) and secure with cotter pins (52). The turnbuckle points downwards.

(Fig. C2.03)

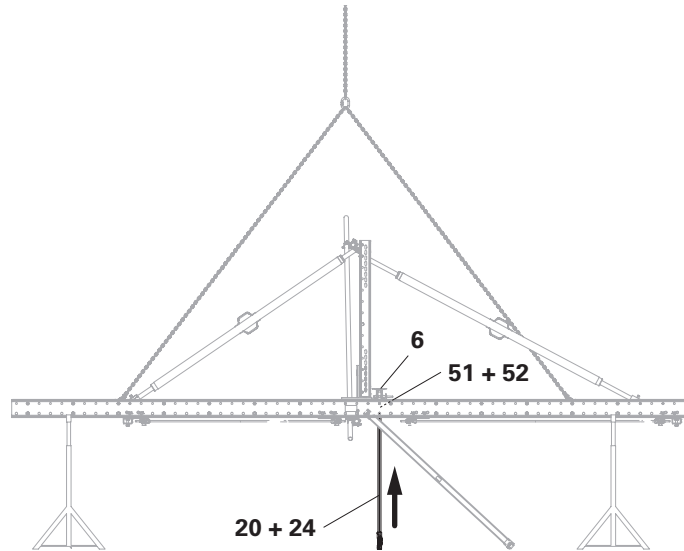

Fig. C2.03

## Components

<b>10</b> Heavy-Duty Spindle SLS 140/240	2x
<b>11</b> Heavy-Duty Spindle SLS 200/300	2x
<b>12</b> Heavy-Duty Spindle SLS 260/360	2x
<b>13</b> Spindle Adapter SLS/RCS	12x
<b>53</b> Fitting pin Ø 26 x 120	6x
<b>54</b> Cotter pin 5/1	6x

### Fitting the Heavy-Duty Spindles SLS

1. Fit Spindle Adapters SLS/RCS (13) onto the thread of the Heavy-Duty Spindles SLS (10 + 11 + 12). Connect them with fitting pins Ø 26 x 120 (53.1) and secure with cotter pins 4/1 (53.2).
2. Fasten the Heavy-Duty Spindles SLS (10 + 11 + 12) to the Climbing Rail RCS 748 (14) with fitting pins Ø 26 x 120 (53) and secure with cotter pins (54).
3. Adjust the heavy-duty spindles (10) so they are the same length as the Diagonal Strut RCS (8).
4. Pivot the heavy-duty spindles (11 + 12) and Diagonal Bracing DW 15 (20) upwards and secure with binding wire.

(Fig. C2.04)

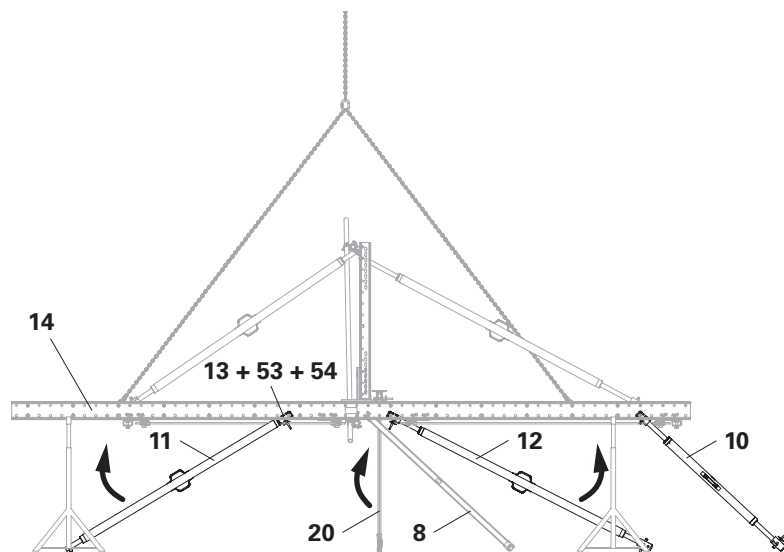

Fig. C2.04

### Connecting the kicker braces and travelling unit



A pre-requisite of the assembly procedure is that work is carried out for a short period of time with the load attached in a positive-locking manner.

#### Components

<b>51</b> Fitting pin $\varnothing 21 \times 120$	2x
<b>52</b> Cotter pin 4/1	2x
<b>53</b> Fitting pin $\varnothing 26 \times 120$	6x
<b>54</b> Cotter pin 5/1	6x

#### Fitting the kicker braces

1. Lower the kicker brace onto the undercarriage with the crane.
2. Fasten the Diagonal Strut RCS (**8**) and Heavy-Duty Spindle (**10**) to the Climbing Rail RCS (**1**) with fitting pins  $\varnothing 26 \times 120$  (**53**) and secure with cotter pins (**54**).
3. Lower the Heavy-Duty Spindle (**12**). Fasten it to the Climbing Rail RCS (**1**) with fitting pins  $\varnothing 26 \times 120$  (**53**) and secure with cotter pins (**54**).
4. Lower Diagonal Bracing DW 15 (**20**). Fasten it to the Steel Waler SRU (**6**) with fitting pins  $\varnothing 21 \times 120$  (**51**) and secure with cotter pins (**52**).
5. Lower the crane lifting gear and calibrate the diagonal bracing.
6. Tension the Diagonal Bracing DW 15 (**20**) and secure with lock nuts.
7. Detach the crane lifting gear from the kicker brace.

(Fig. C2.05)

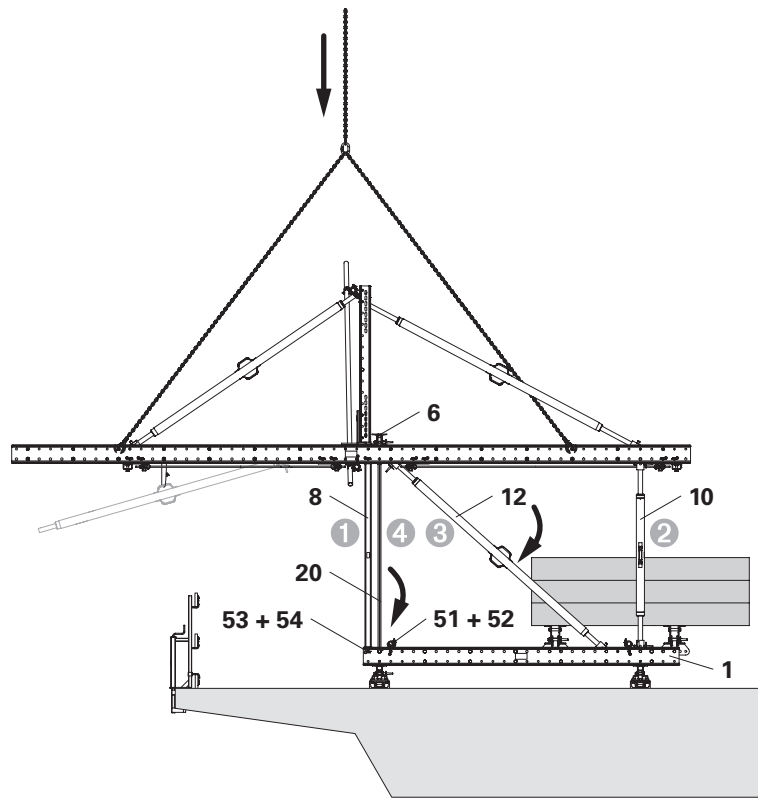

Fig. C2.05

## General information



### Warning

- Risk of falling from unsecured building edges!  
A fall can result in serious injury or even death.  
⇒ Install guardrails.  
⇒ Use personal protective equipment to prevent falling from a height (PPE).
- During assembly on the construction site, components may fall to the ground and hit people below!  
This can lead to serious injuries or even death.  
⇒ Cordon off danger zones beneath the working areas.



A suitable elevating platform is required in order to attach the work platform.

## Components

<b>51</b> Fitting pin Ø 21 x 120	4x
<b>52</b> Cotter pin 4/1	4x

### Flying in the work platform

1. Bolt fitting pins Ø 21 x 120 (**51**) to the Steel Walers SRU (**28**) of the work platform and secure them with cotter pins 4/1 (**52**).
2. Attach the crane lifting gear to the fitting pins Ø 21 x 120 (**51**) and fly in the work platform.  
(Fig. C3.01)

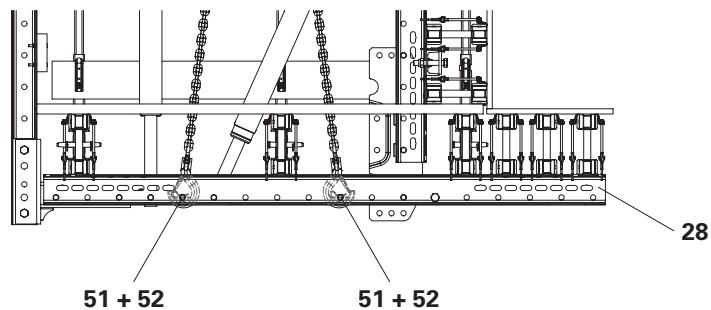

Fig. C3.01



# C3 Attaching the concreting platform

## Components

<b>51</b> Fitting pin Ø 21 x 120	2x
<b>52</b> Cotter pin 4/1	2x
<b>53</b> Fitting pin Ø 26 x 120	4x
<b>54</b> Cotter pin 5/1	4x

## Assembly

1. Fasten the Elbow Connection RCS/ SRU (**15**) and Spindle Adapter SLS/ RCS (**13**) to the Climbing Rail RCS (**14**) with fitting pins Ø 26 x 120 (**53**) and secure with cotter pins (**54**).
2. Fasten the Heavy-Duty Spindle 200/300 (**11**) to the Steel Waler SRU (**27**) with fitting pins Ø 21 x 120 (**51**) and secure with cotter pins (**52**).
3. Remove crane lifting gear.
4. Remove the Heavy-Duty Spindle SLS (**10**).
5. Complete the platform planking of the concreting platform. (Fig. C3.02)

Figure C3.03 shows a side view of the fully assembled formwork carriage unit.

Assemble the next formwork carriage unit in the same way and position it on the bridge.

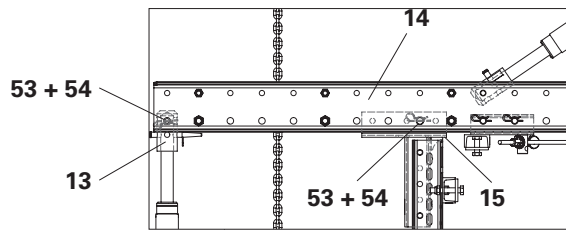

Fig. C3.02a

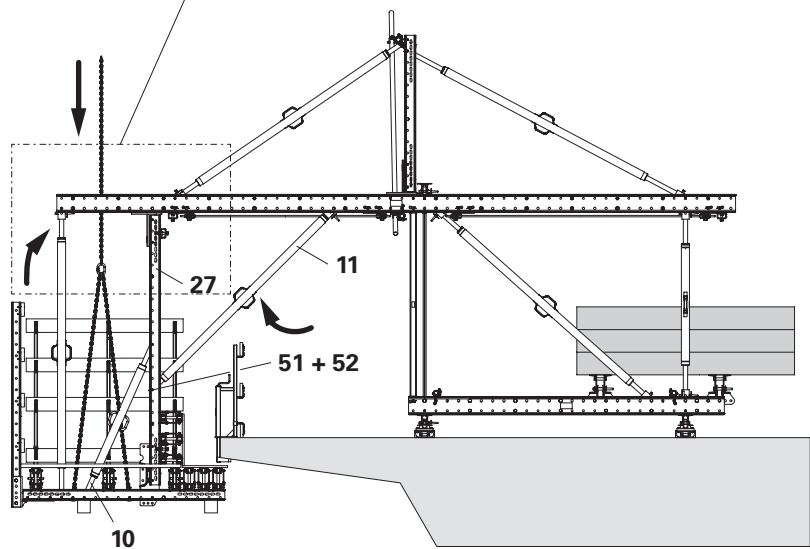

Fig. C3.02

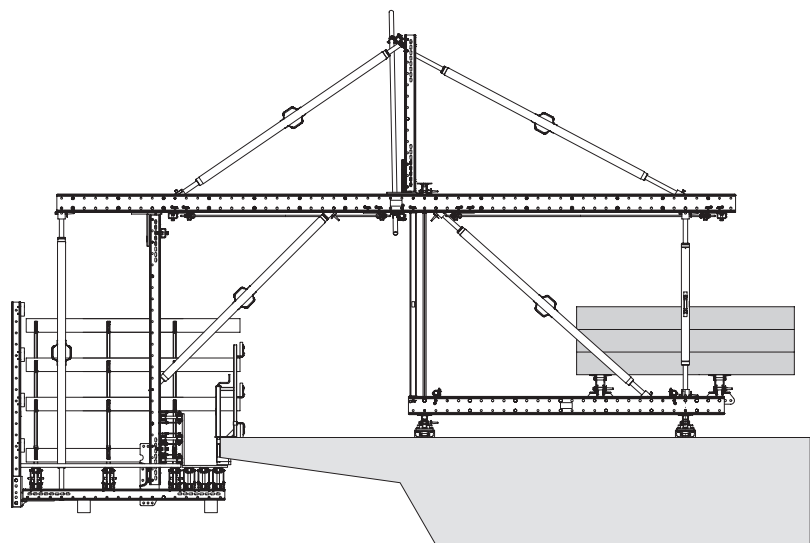

Fig. C3.03

## Anchoring in the longitudinal direction



- Anchoring in the longitudinal direction is only necessary if there is a longitudinal inclination in the carriageway.
- PERI recommends anchoring the formwork carriage units in the longitudinal direction even if there is no longitudinal inclination in the carriageway. This makes it easier to adjust the formwork carriage units in relation to each other.

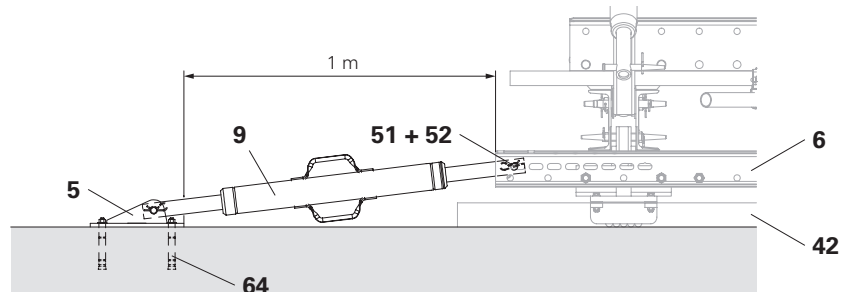

Fig. C4.01

### Components

<b>5</b> Bracing Shoe RCS DW 15	2x
<b>9</b> Heavy-Duty Spindle SLS 80/140	2x
<b>51</b> Fitting pin $\varnothing$ 21 x 120	2x
<b>52</b> Cotter pin 4/1	2x
<b>64</b> Heavy-duty dowel	4x

### Assembly

1. Screw the Bracing Shoe RCS (**5**) in the extension of the U-sections (**42**) firmly into the base plate using heavy-duty dowels (**64**). The travelling unit should be at a distance of 1 m from the Steel Waler SRU (**6**).
2. Fasten the Heavy-Duty Spindle SLS (**9**) to the Steel Waler SRU (**6**) and Bracing Shoe RCS (**5**) with fitting pins  $\varnothing$  21 x 120 (**51**). Secure with cotter pins (**52**).

(Fig. C4.01 + C.4.02)

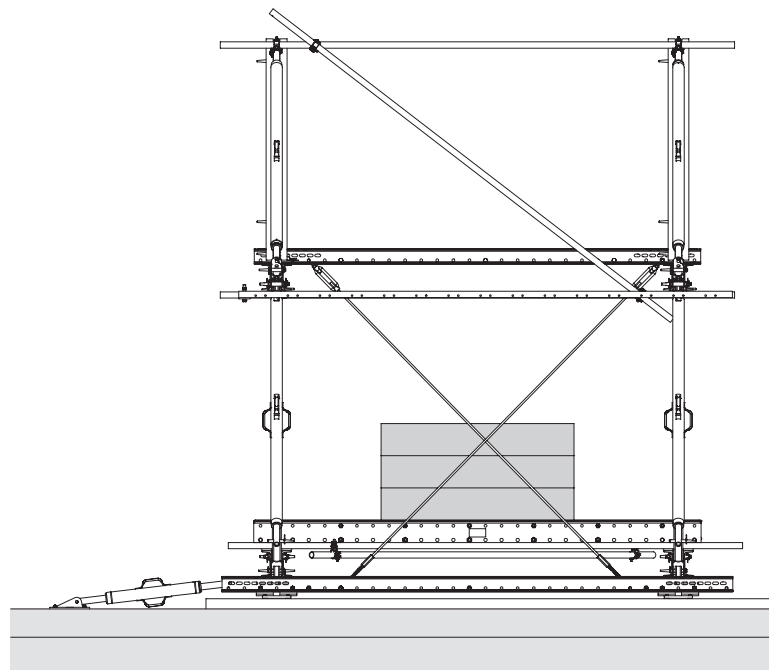

Fig. C4.02

## Linking the formwork carriage units

### Components

<b>9</b> Heavy-Duty Spindle SLS 80/140	2x
<b>51</b> Fitting pin Ø 21 x 120	4x
<b>52</b> Cotter pin 4/1	4x

### Assembly

1. Bolt the Heavy-Duty Spindle SLS (**9**) to the Steel Walers SRU (**6**) with fitting pins Ø 21 x 120 (**51**). Secure with cotter pins (**52**).

(Fig. C5.01 + C5.02)

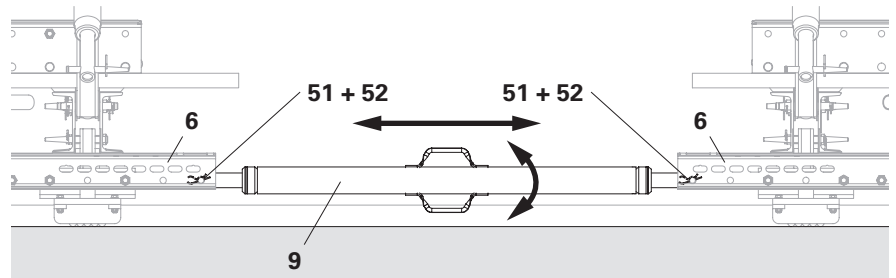

Fig. C5.01



- The formwork of the cantilevered parapet can be aligned with the coupling spindle to ensure there are no gaps.
- Alignment is carried out once when the formwork carriage units are linked. Subsequent adjustment is not necessary.

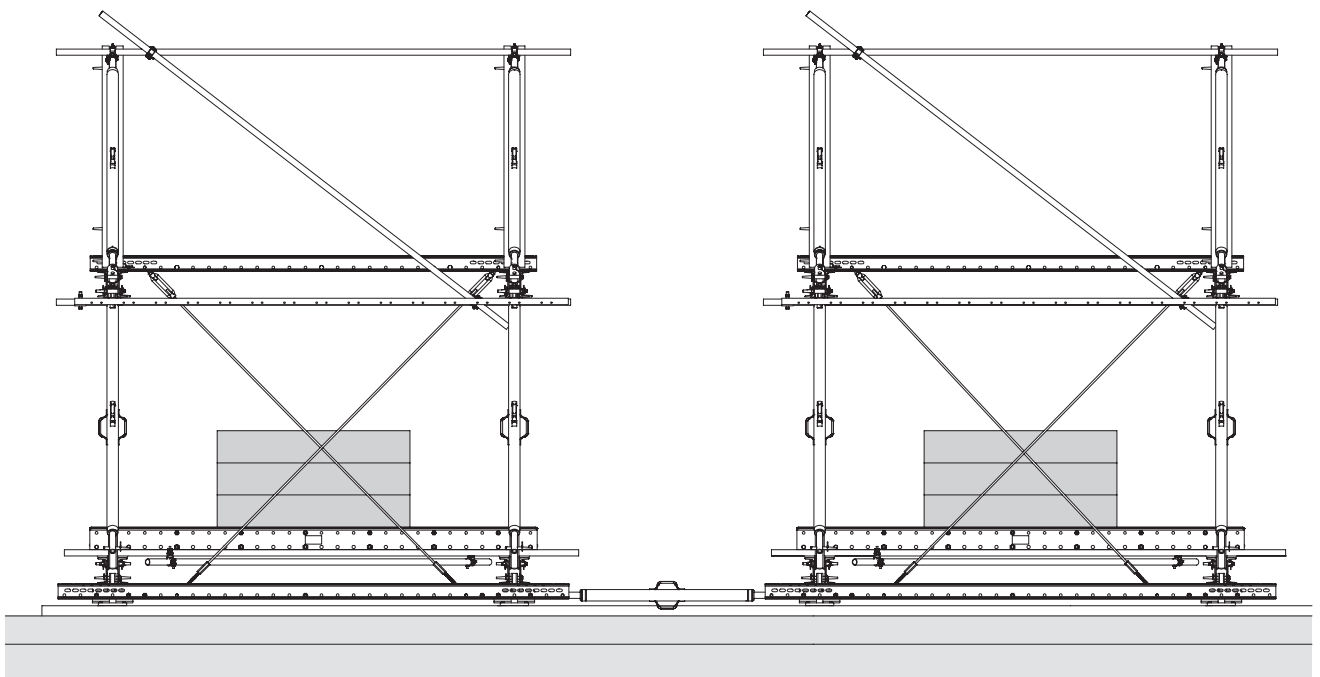

Fig. C5.02

## Sequence of operation

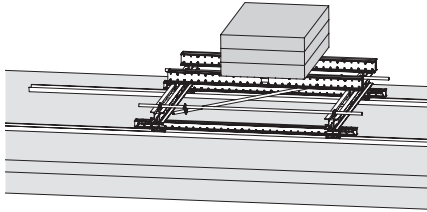

Fig. D1.01

### Assembly

Lay out and align the U-sections.  
Position the first travelling unit.

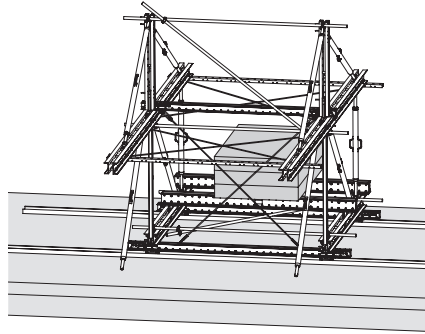

Fig. D1.02

Mount kicker braces on the travelling unit.

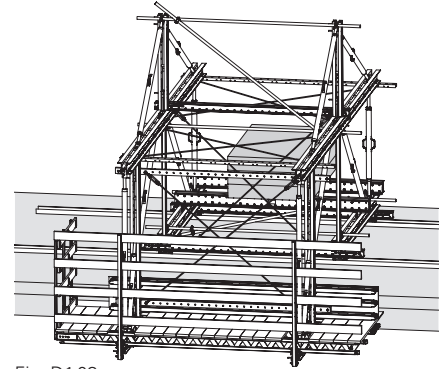

Fig. D1.03

Attach the concreting platform.

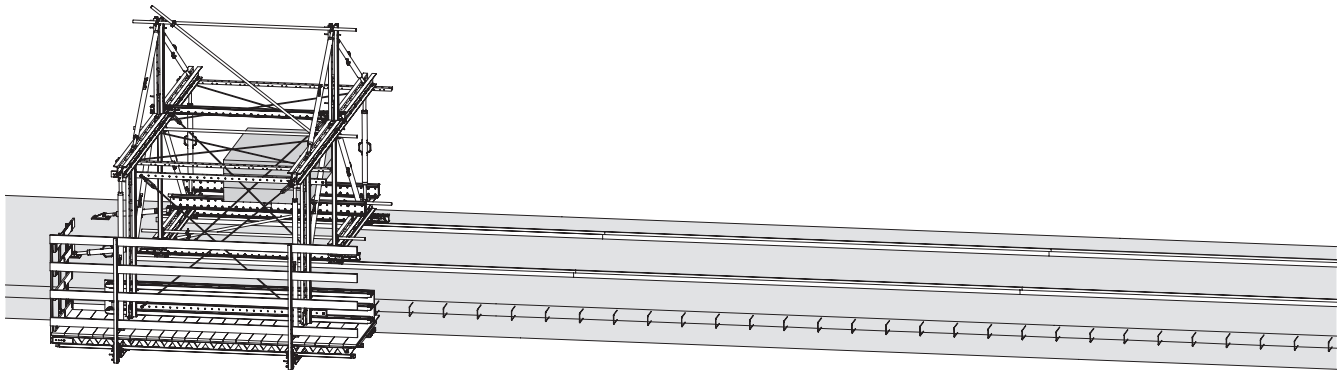

Fig. D1.04

Anchor the first formwork carriage unit.

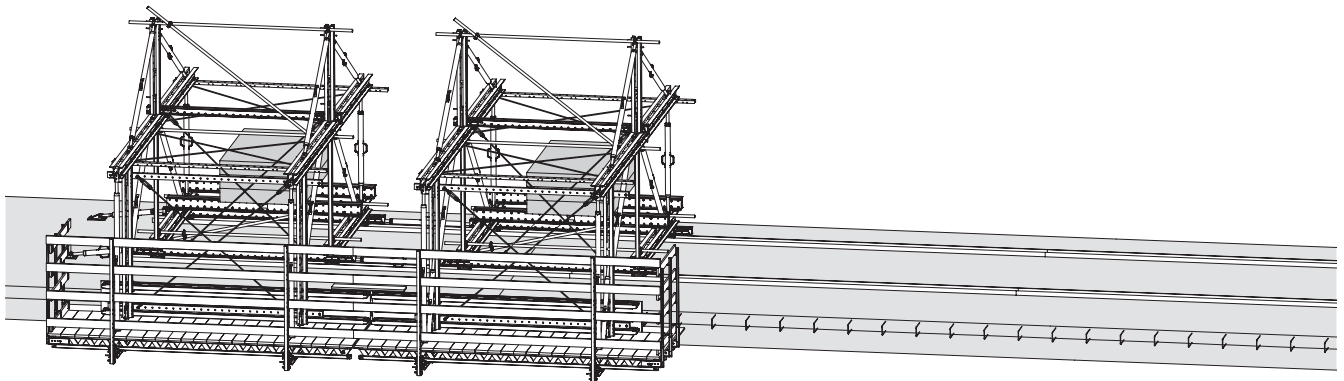

Fig. D1.05

Set up the second formwork carriage unit and link both formwork carriage units.

Align the concreting platforms. Make sure that the gap between the formwork elements is closed. Connect the concreting platforms with a timber strap.  
(Fig. D1.06)

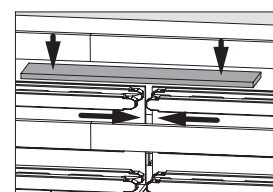

Fig. D1.06

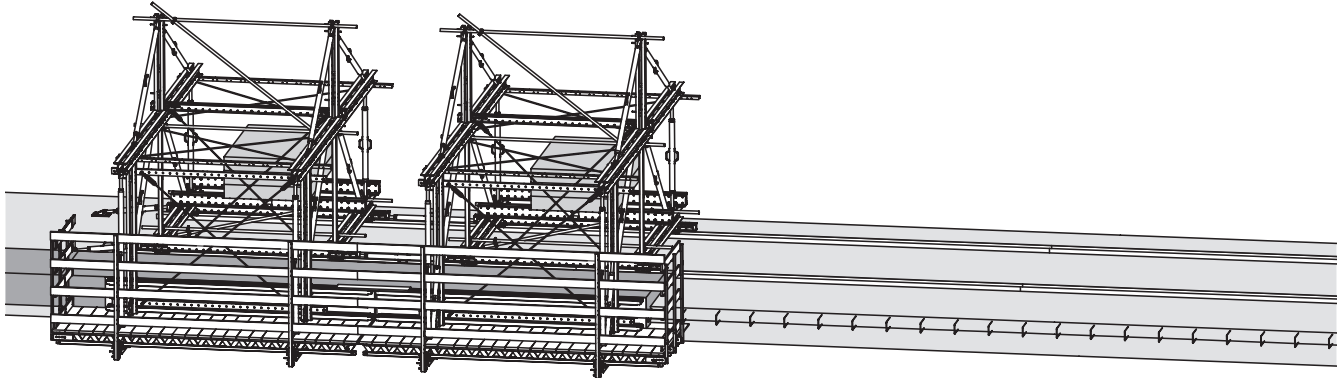

Fig. D1.07

## 1. Work cycle

Concrete cantilevered parapet.

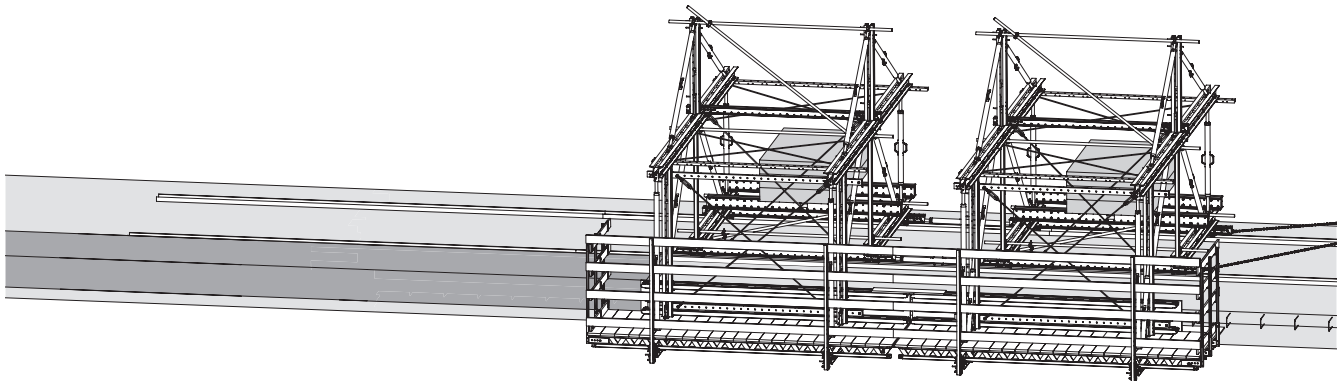

Fig. D1.08

## 2. Work cycle

Move the cantilevered parapet carriage to the next concreting section.

The concreting platform adjustment phase is made up of three steps. If necessary, repeat the steps until the concreting platform is aligned correctly.

## Adjusting the slab formwork



### Danger

Open building edges on and between the concreting platforms appear when the cantilevered parapets are struck. Potentially fatal injuries could occur due to falling.

- ⇒ Only tilt and slew the concreting platform to the extent required.
- ⇒ Leave the danger zone or wear PPE.

### 1. Rotate the Heavy-Duty Spindle SLS (12a).

- The concreting platform tilts around **pivot point 1**.
- During the striking process, the slab formwork comes away from the cantilevered parapet when the heavy-duty spindle is shortened.

(Fig. D1.09)

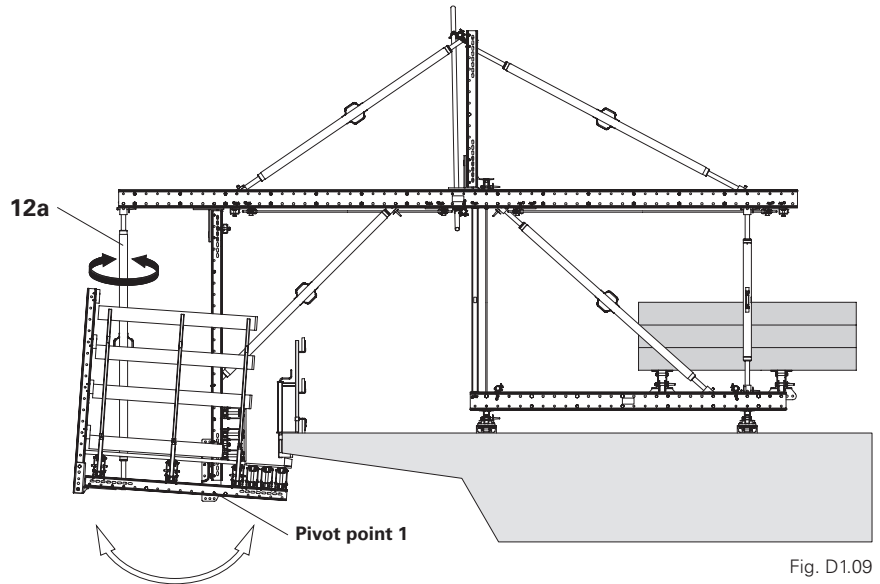

Fig. D1.09

## Adjusting the side formwork

### 2. Rotate the Heavy-Duty Spindle SLS (11).

- The concreting platform tilts around **pivot point 2**.
- During the striking process, the side formwork comes away from the cantilevered parapet when the heavy-duty spindle is extended.

(Fig. D1.10)

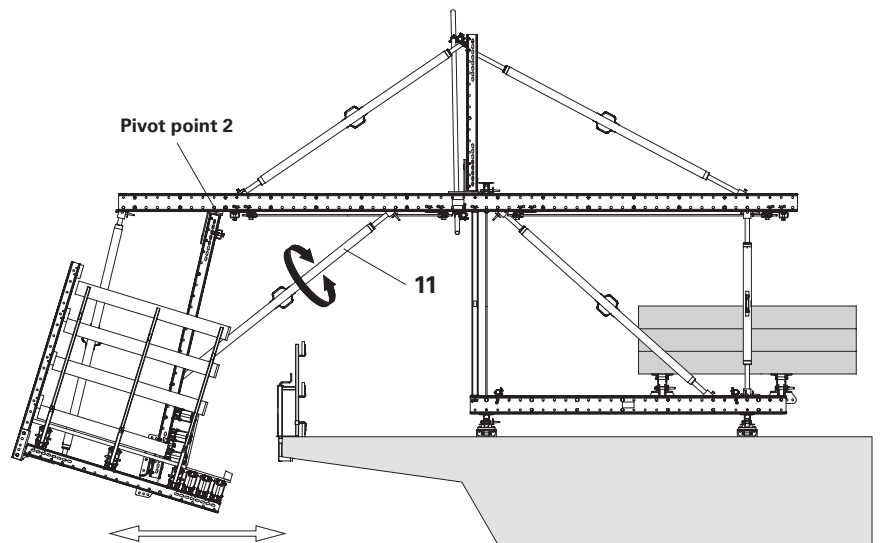

Fig. D1.10

## Adjusting the height

### 3. Rotate Heavy-Duty Spindle SLS (10) and readjust Heavy-Duty Spindle SLS (12b).

- The kicker brace rotates around **pivot point 3** causing the concreting platform to move up and down.

(Fig. D1.11)

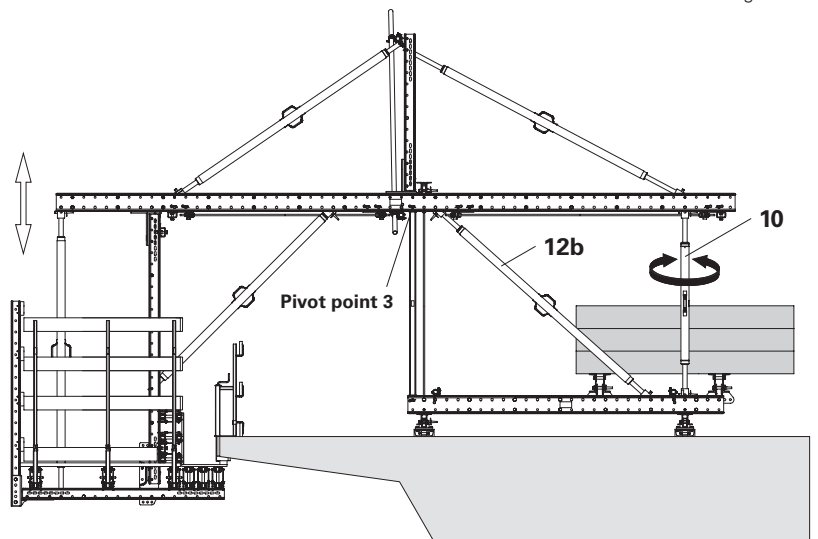

Fig. D1.11

## Connecting the concreting platforms

4. Screw timber straps (45) onto the Girders GT 24 of the side formwork and connect the concreting platforms.

(Fig. D1.12 + D1.12a)

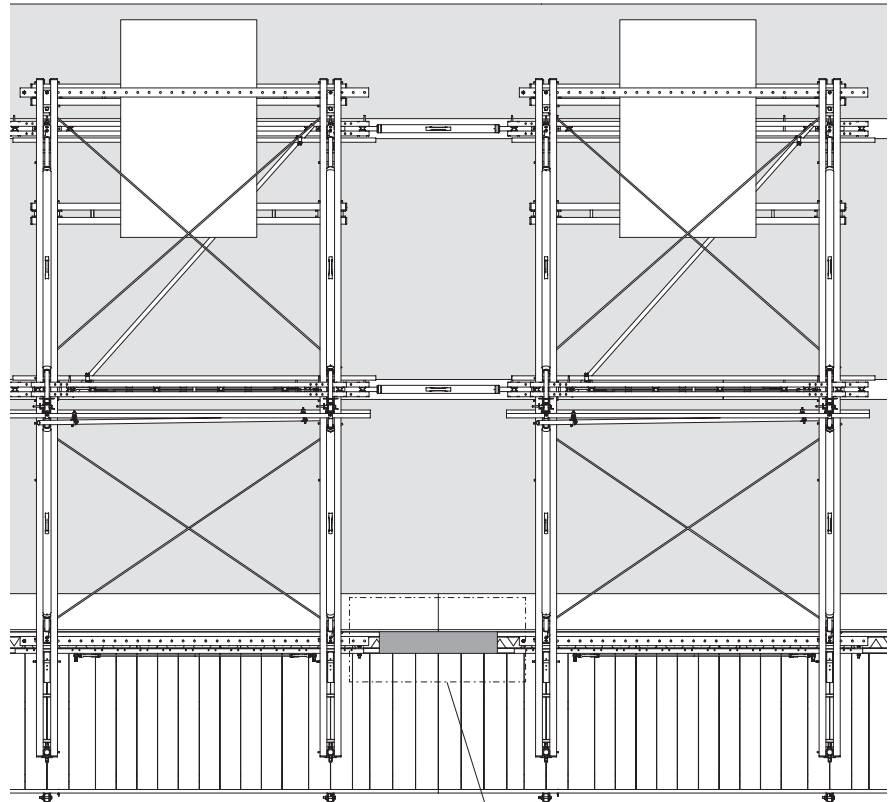

Fig. D1.12

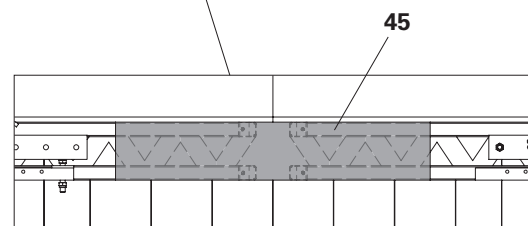

Fig. D1.12a

## Concreting position



### Danger

Danger associated with overloading!  
The VGW Cantilevered Parapet Carriage may tilt, or the concreting platform may fall to the ground.

- ⇒ Do not pour concrete directly into the formwork. (Fig. D2.01)
- ⇒ Fill the formwork evenly, avoid any accumulation of concrete. (Fig. D2.02)

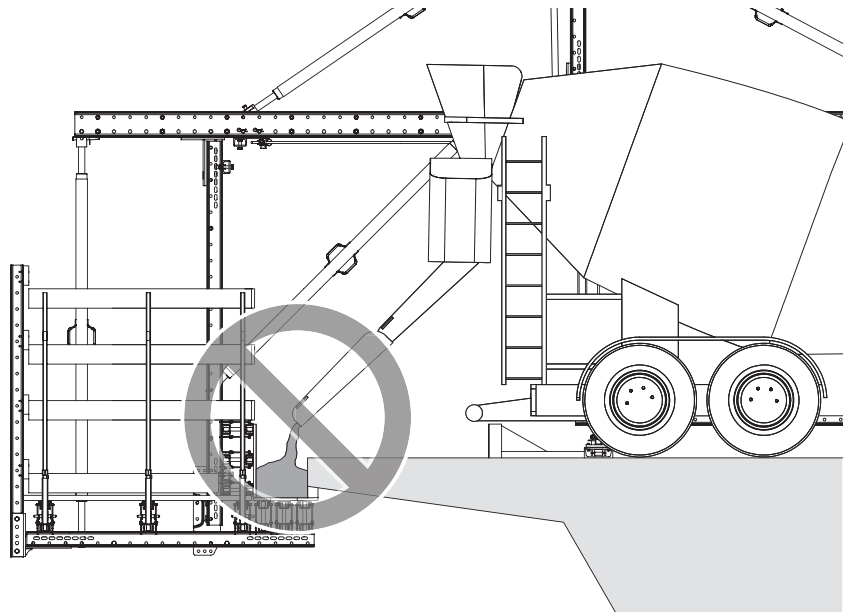

Fig. D2.01

## Concreting

1. Pour concrete on the bridge cantilever.
2. Put concrete into the formwork construction using a rake or something similar.
3. Compact the concrete. (Fig. D2.02)

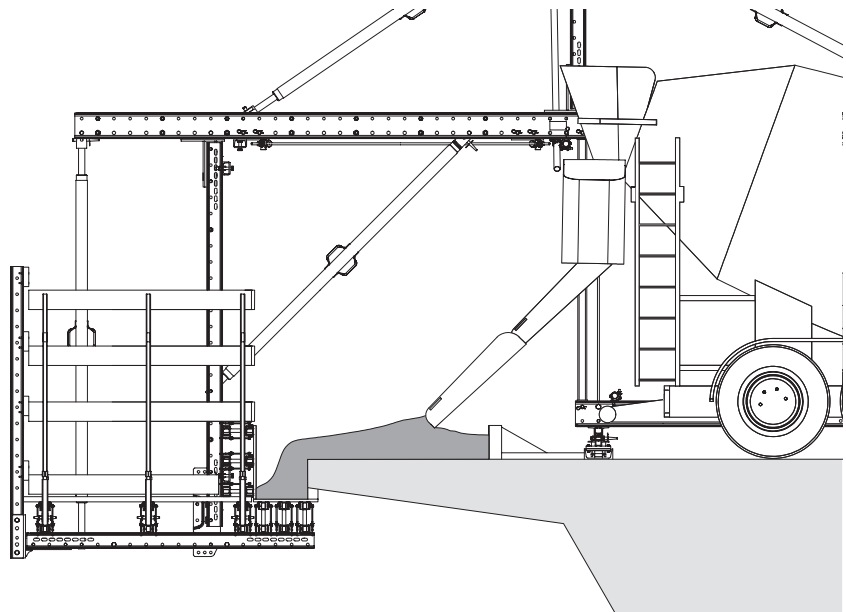

Fig. D2.02



## Danger

Open building edges on and between the concreting platforms appear when the cantilevered parapets are struck. Potentially fatal injuries could occur due to falling.

- ⇒ Only tilt and slew the concreting platform to the extent required.
- ⇒ Leave the danger zone or wear PPE.

## 

Before striking the cantilevered parapet

- Remove materials and tools from the concreting platform.
- Remove timber straps and release the connection between the concreting platforms.

### Releasing the slab formwork

1. Retract the Heavy-Duty Spindle SLS (12a).

→ The slab formwork comes away from the cantilevered parapet.

## 

Tilt the concreting platform until the rear formwork (46) pivots away from the concrete edge of the cantilevered parapet. (Fig. D3.01)

### Releasing the side formwork

1. Extend the Heavy-Duty Spindle SLS (11).

→ The side formwork comes away from the cantilevered parapet.

## 

Pivot the concreting platform outwards until there is a gap of at least 10 cm between the formwork and the cantilevered parapet. (Fig. D3.02)

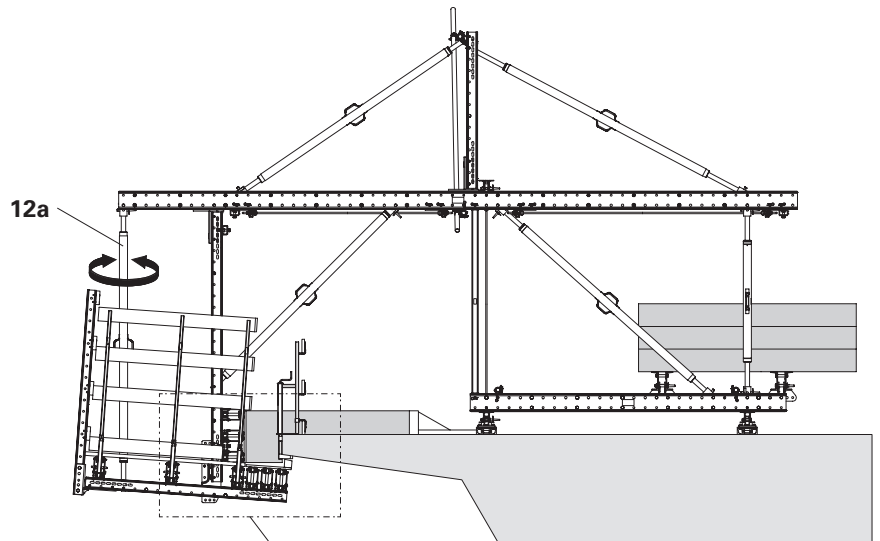

Fig. D3.01

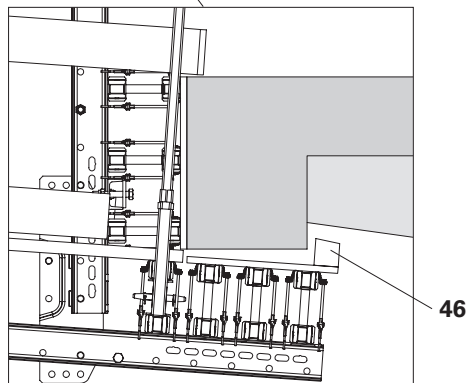

Fig. D3.01a

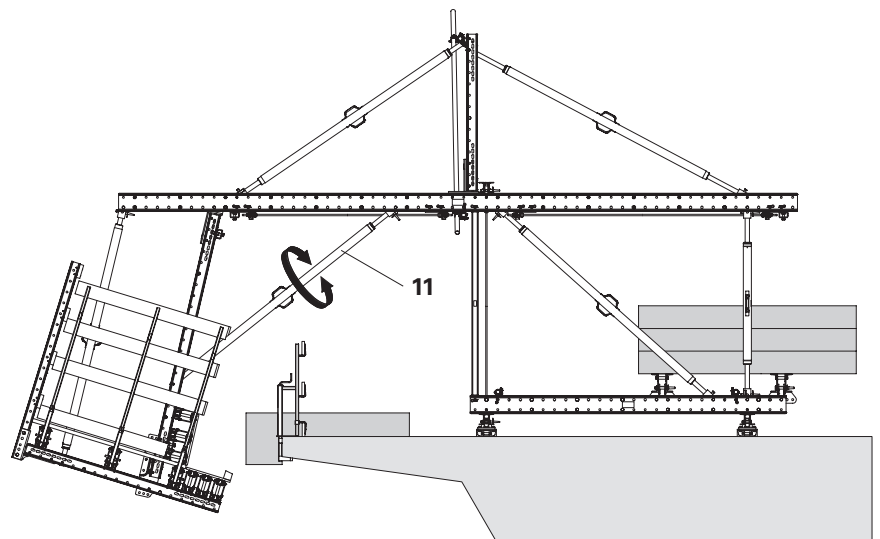

Fig. D3.02



- A suitable relocation device should be provided by the contractor, e.g. wheel loader, tractor or winch unit.
- If the bridge is subject to a longitudinal inclination, a second relocation device is required for braking purposes.



- Keep the total weight of the cantilevered parapet carriage in mind.
- Use one pulling unit only.
- Attach chains of equal length to the attachment point on both base beams.
- Avoid any jerky movements.
- Move the cantilevered parapet carriage slowly and smoothly.
- Keep the U-sections clean, remove objects from the U-sections.



## Danger

Heavy moving assembly!  
There is a risk of crushing when relocating the cantilevered parapet carriage.

⇒ Leave the danger zone.

## Components

<b>42</b>	U-section	
<b>47</b>	Relocation device	
<b>51</b>	Fitting pin Ø 21 x 120	2x
<b>52</b>	Cotter pin 4/1	2x

## Moving

1. Set down and position the U-sections (**42**) for the next concreting section and, if necessary, secure them to prevent them from slipping.
2. Clean the U-sections.
3. Fasten the relocation device (**47**) to the slot of the Steel Waler Universal SRU (**6**) with fitting pin Ø 21 x 120 (**51**) and secure with cotter pin 4/1 (**52**).
4. Tension the relocation device and remove the anchoring for the cantilevered parapet carriage.
5. Pull the cantilevered parapet carriage to the next concreting section.
6. Anchor the cantilevered parapet carriage. See "Anchoring in the longitudinal direction" on page 50.
7. Align the concreting platforms and connect them with timber straps. (Fig. D4.01)



- The U-sections are simply laid out and butted up against each other.
- It is not normally necessary to connect or fix the U-sections in place.
- If the U-sections shift due to, for example, an inclination in the carriage-way, then fix the U-sections in place.

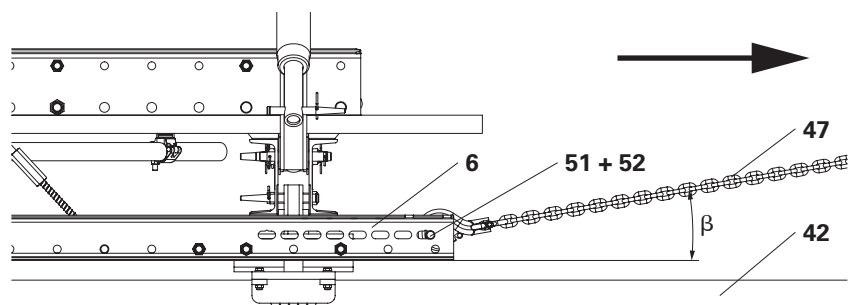

Fig. D4.01



The following rule of thumb applies to the chain length:

**Length of the chains  $\geq$  distance between the attachment points.**

(Fig. D4.02)

The following applies to the angles  $\alpha$  and  $\beta$ :

$\alpha \leq 30^\circ$

$\beta \leq 30^\circ$

(Fig. D4.01 + D4.02)

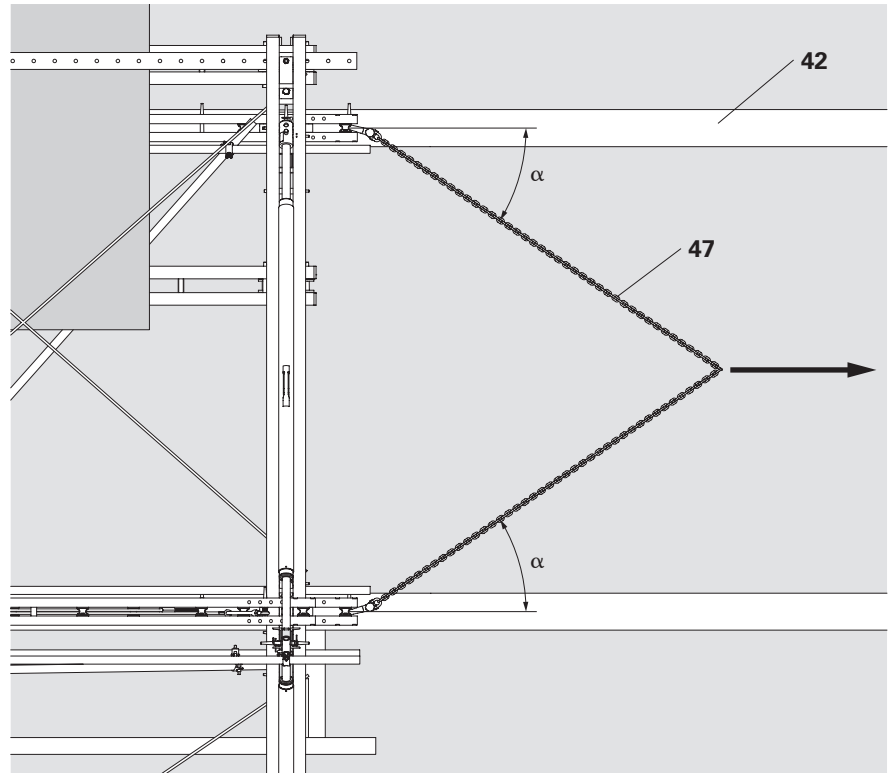

Fig. D4.02



- The dismantling area must be level and must have sufficient load-bearing capacity.
- Keep sufficient space available for temporary storage of assemblies.
- Secure interim dismantling states by means of temporary supports in order to prevent any items from toppling over.

## Striking the cantilevered parapet

### Striking procedure

1. Release the slab formwork with Heavy-Duty Spindle SLS (**12**).
2. Release the side formwork with Heavy-Duty Spindle SLS (**11**) and pivot the concreting platform outwards. (Fig. E1.01)

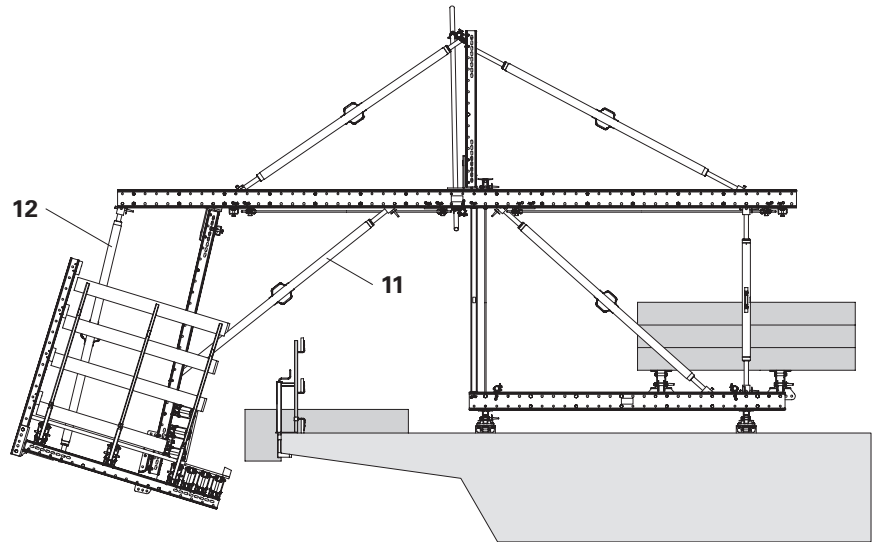

Fig. E1.01

## Removing the kicker braces



- Remove all loose parts from the platform and formwork or secure them to prevent them from falling before commencing the lifting out procedure.
- Do not transport any persons during the lifting out procedure.

### Lifting out procedure

1. Attach four-sling lifting gear to the Climbing Rail RCS (**14**) and tension it. If necessary, run a series of tests to determine the centre of gravity.
2. Unscrew and remove the bolts from the Diagonal Bracing DW 15 ACS (**20**) on the bottom of the climbing rail (**1**).
3. Remove the bolts from the Diagonal Strut RCS (**8**), Heavy-Duty Spindles SLS (**10**) and (**12b**) on the bottom of the climbing rail (**1**).
4. Remove the kicker braces together with the concreting platform. (Fig. E1.02 + E1.03)

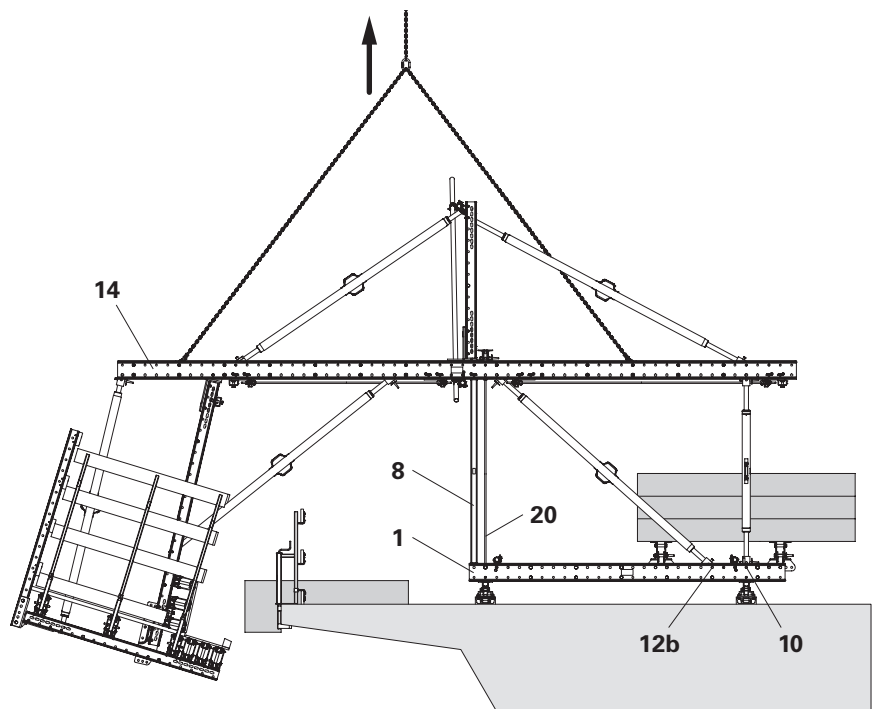

Fig. E1.02

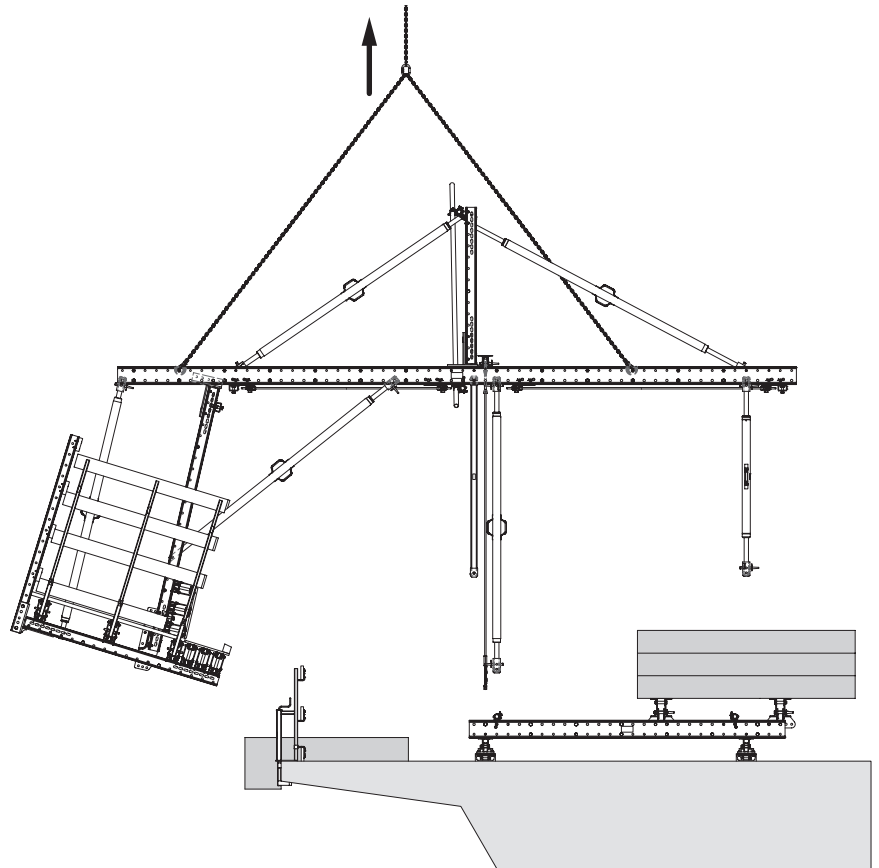

Fig. E1.03

## Dismantling the concreting platform



### Caution

Components may topple over or swing back and forth once the fitting pins are removed.

Freely moving components may cause injuries.

⇒ Hold onto components firmly when removing the bolts, and then set them down.

5. Set the concreting platform down on two squared timbers.
6. Remove the bolts from the Heavy-Duty Spindle SLS (11) on the Steel Waler SRU (27).
7. Remove the bolts from the Heavy-Duty Spindle SLS (12) and Elbow Connection RCS/SRU (15) on the Climbing Rail RCS (14).
8. Dismantle the concreting platform. (Fig. E1.04)

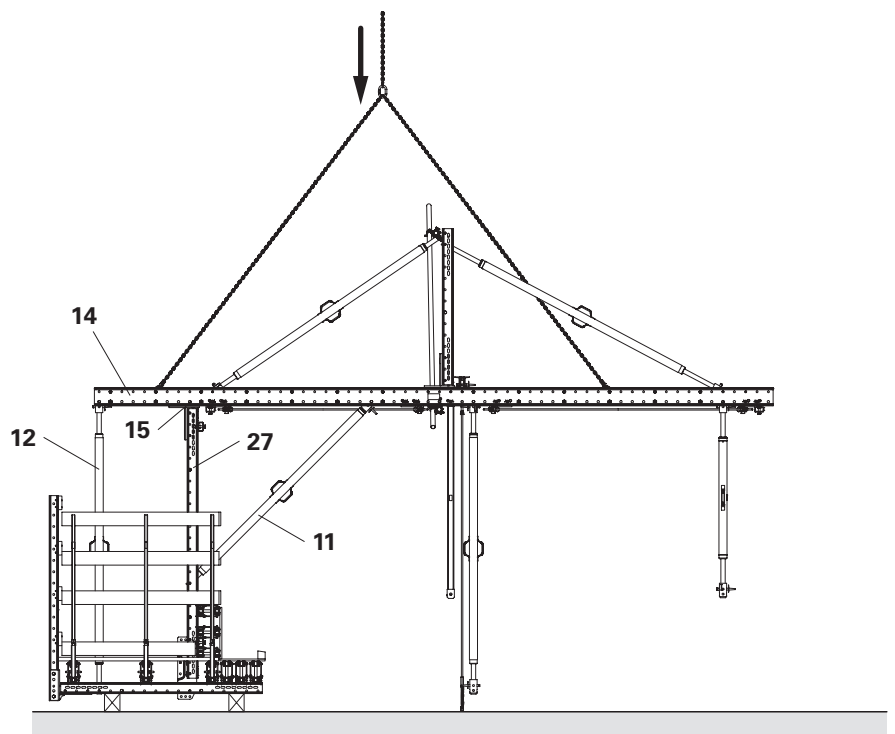

Fig. E1.04

## Disassembling the kicker braces

1. Have scaffold stands at the ready.
2. Set the kicker braces down on the scaffold stands and disassemble them.

(Fig. E1.05 + E1.06)

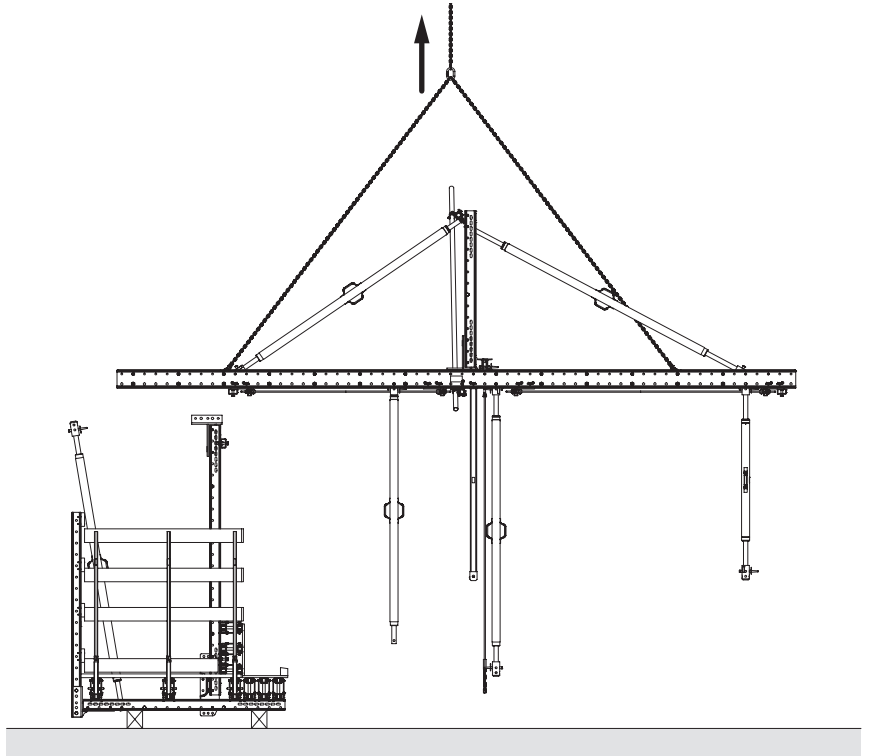

Fig. E1.05

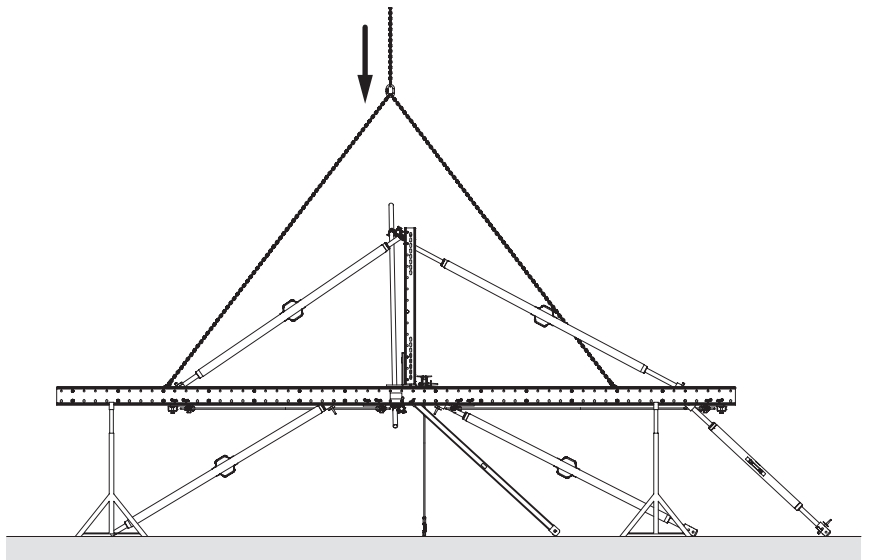

Fig. E1.06

## Removing the ballast

Attach the ballast to the crane and set it down next to the assembly area.  
(Fig. E1.07)

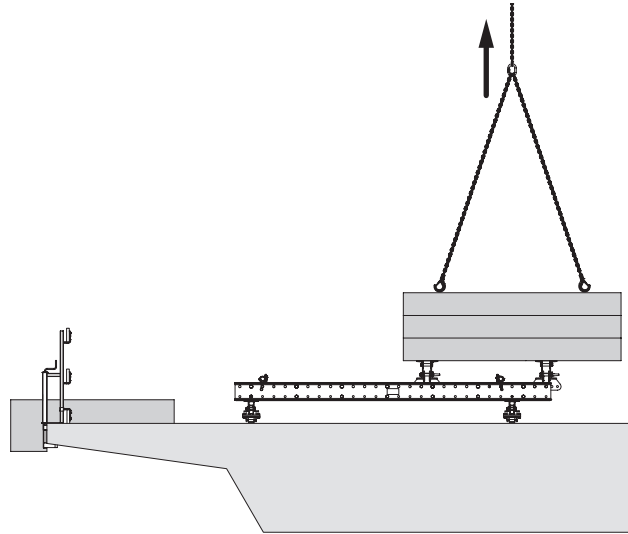

Fig. E1.07

## Disassembling the travelling unit

1. Position squared timbers on the dismantling area.
2. Attach the travelling unit to the crane and set it down on the squared timbers.
3. Disassemble the travelling unit.  
(Fig. E1.08)

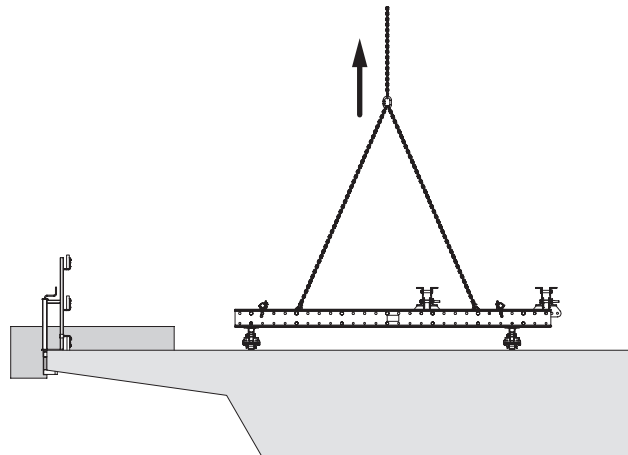
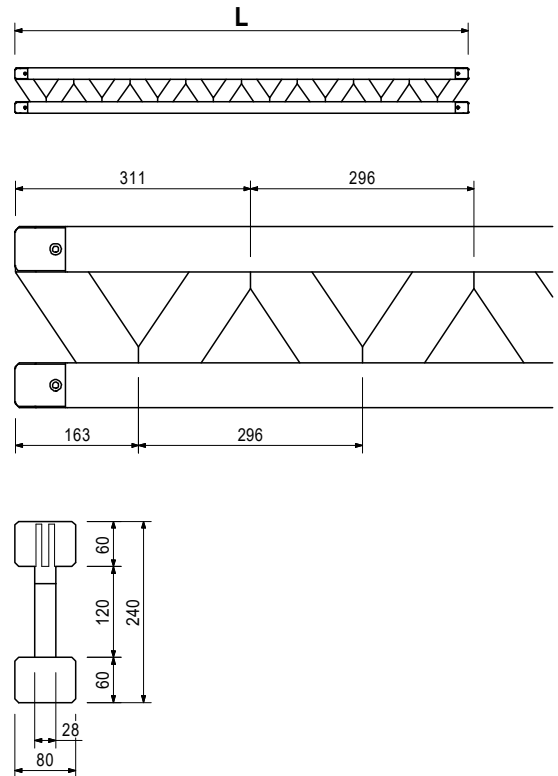
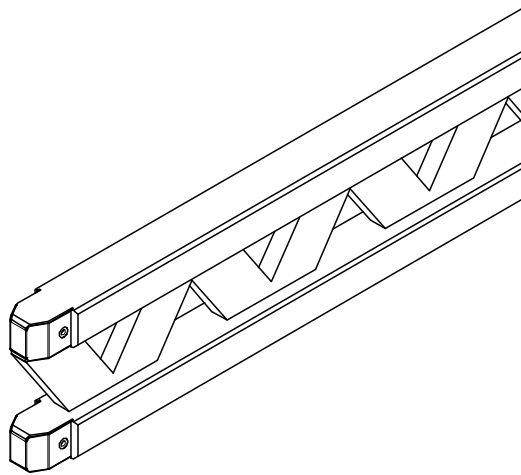

Fig. E1.08

# VGW Cantilevered Parapet Carriage

Article no. Weight kg

Article no.	Weight kg	Formwork Girder GT 24	L
075100	5.300	Formwork Girder GT 24, l = 0.90 m	918
075120	7.100	Formwork Girder GT 24, l = 1.20 m	1,214
075150	8.900	Formwork Girder GT 24, l = 1.50 m	1,510
075180	10.600	Formwork Girder GT 24, l = 1.80 m	1,806
075210	12.400	Formwork Girder GT 24, l = 2.10 m	2,102
075240	14.200	Formwork Girder GT 24, l = 2.40 m	2,398
075270	15.900	Formwork Girder GT 24, l = 2.70 m	2,694
075300	17.700	Formwork Girder GT 24, l = 3.00 m	2,990
075330	19.500	Formwork Girder GT 24, l = 3.30 m	3,286
075360	21.200	Formwork Girder GT 24, l = 3.60 m	3,582
075390	23.000	Formwork Girder GT 24, l = 3.90 m	3,878
075420	24.800	Formwork Girder GT 24, l = 4.20 m	4,174
075450	26.600	Formwork Girder GT 24, l = 4.50 m	4,470
075480	28.300	Formwork Girder GT 24, l = 4.80 m	4,766
075510	30.100	Formwork Girder GT 24, l = 5.10 m	5,062
075540	31.900	Formwork Girder GT 24, l = 5.40 m	5,358
075570	33.600	Formwork Girder GT 24, l = 5.70 m	5,654
075600	35.400	Formwork Girder GT 24, l = 6.00 m	5,950





# VGW Cantilevered Parapet Carriage

Article no.	Weight kg
074990	8.230
074905	12.010
074910	13.630
074890	14.710
074920	16.060
074930	18.220
074940	19.840
074950	21.460
074960	24.700
074970	26.860
074980	32.260
074900	0.000

**Girder VT 20K with Steel Cap**  
**Girder VT 20K, L = 1.45 m**  
**Girder VT 20K, L = 2.15 m**  
**Girder VT 20K, L = 2.45 m**  
**Girder VT 20K, L = 2.65 m**  
**Girder VT 20K, L = 2.90 m**  
**Girder VT 20K, L = 3.30 m**  
**Girder VT 20K, L = 3.60 m**  
**Girder VT 20K, L = 3.90 m**  
**Girder VT 20K, L = 4.50 m**  
**Girder VT 20K, L = 4.90 m**  
**Girder VT 20K, L = 5.90 m**  
**Cutting Cost VT Girder**

Universal formwork girder made of wood.

L
1,447
2,152
2,452
2,652
2,902
3,292
3,592
3,892
4,492
4,902
5,902

**Note**

The girder fulfils all requirements of DIN EN 13377 Class P20 (Declaration of Conformity).

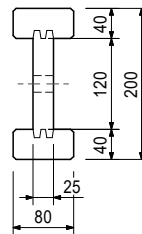
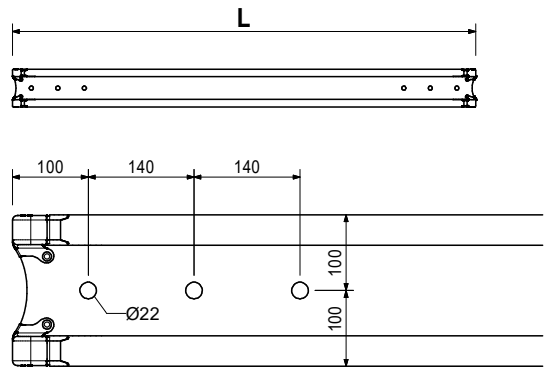
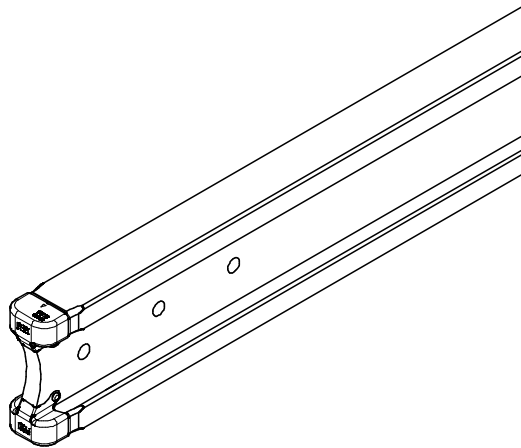

024070 0.691

**Hook Strap HB 24-100/120, galv.**

For fixing Girders GT 24 to Steel Walers SRZ, SRU and BR: U100 – U120.

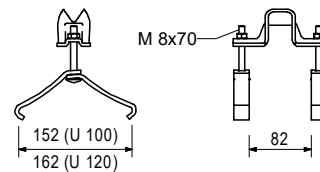
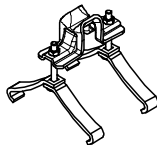

# VGW Cantilevered Parapet Carriage

Article no.	Weight kg
024080	0.735

## Hook Strap HB 24-140/160, galv.

For fixing Girders GT 24 to Steel Walers SRZ, SRU and BR: U140 – U160.

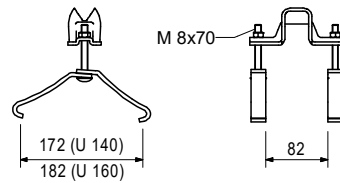
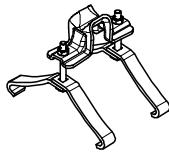

104931	0.865
--------	-------

## Hook Strap Uni HBU 20-24

For fixing Girders GT 24 or VT 20 to Steel Walers SRZ or SRU profile U100 – U140.

### Note

The girders can be mounted at right-angles or diagonally to the steel walers and also outside of the nodes.

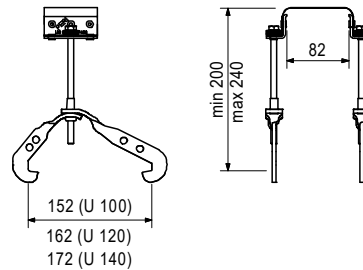
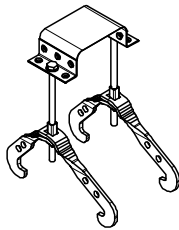

024540	0.005
--------	-------

Accessories

## TSS-Torx 6 x 40, galv.

103845	0.893
--------	-------

## Hook Strap Uni HBU 24-28

For fixing Girders GT 24 to Steel Walers SRZ, SRU and BR: U100 – U140.

### Note

The girders can be mounted at right-angles or diagonally to the steel walers and also outside of the nodes.

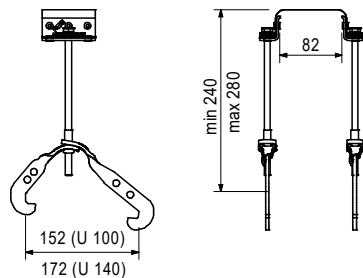
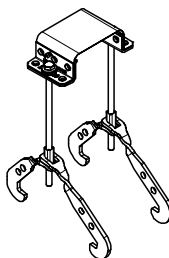

024540	0.005
--------	-------

Accessories

## TSS-Torx 6 x 40, galv.

# VGW Cantilevered Parapet Carriage

Article no.	Weight kg
104930	0.887

## Hook Strap Uni Double HBUD 20-24

For fixing 2 Girders GT 24 or VT 20 to Steel Walers SRZ or SRU profile U100 – U140.

### Note

The girders can be mounted at right-angles or diagonally to the steel walers and also outside of the nodes.

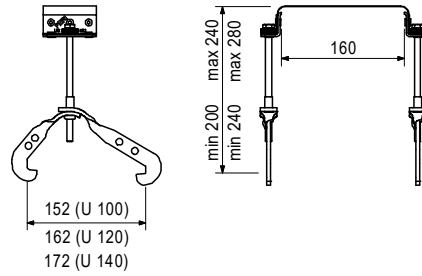
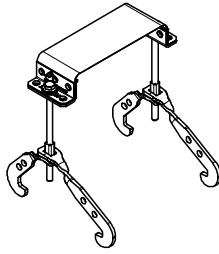

104096	0.912
--------	-------

## Hook Strap Uni Double HBUD 24-28

For fixing 2 Girders GT 24 or VT 20 to Steel Walers SRZ and SRU profile U100 – U140.

### Note

The girders can be mounted at right-angles or diagonally to the steel walers and also outside of the nodes.

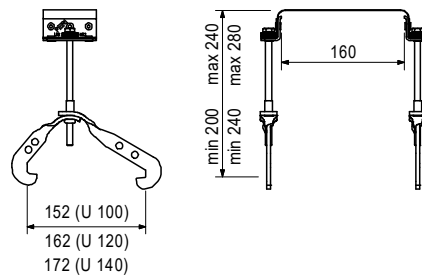
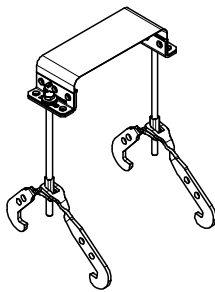

024860	0.616
--------	-------

## Hook Strap HB 24 Cross Strap 150, galv.

For fixing Girders GT 24 or VT 20 to Steel Walers SRZ, SRU and BR: U100 - U120 outside of the girder nodes and squared timber.

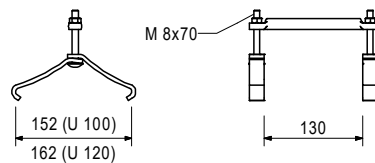
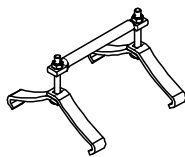

024600	0.907
--------	-------

## Girder Claw HB

For fixing the Edge Beam GT 24 to the Steel Walers SRZ and SRU, profile U100 – U120.

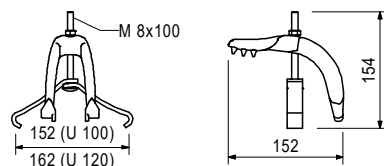
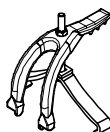

# VGW Cantilevered Parapet Carriage

Article no.	Weight kg
024640	0.923

## Quick Str. Hook Strap 24-100/140, galv.

For fixing Girders GT 24 to Steel Walers SRZ, SRU, Profile U100 – U140 outside of the girder nodes.

## Note

Girders fixed in position with the quick strap must be specially screwed to the formlining when using crane lifting units.

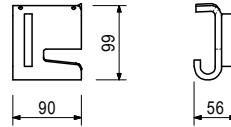
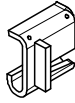

024630	0.742
--------	-------

## Fix Strap U100 – U120, galv.

For fixing the Girders GT 24 in the VARIO corner.

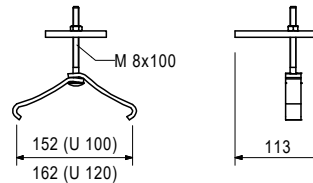

114166	78.200
109469	130.000
112102	156.000
109470	182.000
112141	209.000
109471	262.000
109472	393.000
109610	524.000

## Climbing Rails RCS

- Climbing Rail RCS 148
- Climbing Rail RCS 248
- Climbing Rail RCS 298
- Climbing Rail RCS 348
- Climbing Rail RCS 398
- Climbing Rail RCS 498
- Climbing Rail RCS 748
- Climbing Rail RCS 998

## L

- 1,480
- 2,480
- 2,980
- 3,480
- 3,980
- 4,980
- 7,480
- 9,980

Steel profile for all-purpose use for climbing or civil engineering applications.  
With spacers M20-82 and M24-82.

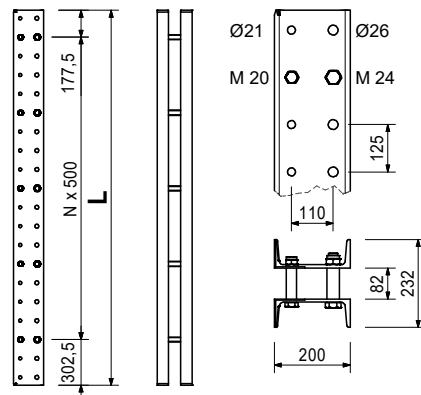

110022	0.491
--------	-------

## Spacer M20-82

Spacer for Climbing Rails RCS.

## Complete with

- 1 pc. 104477 bolt ISO 4014 M20 x 120-8.8, galv.
- 1 pc. 130341 nut ISO 7042 M20-8, galv.

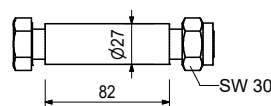
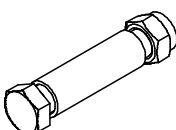

Article no.	Weight kg
110023	0.910

**Spacer M24-82**  
Spacer for Climbing Rails RCS.

**Complete with**  
1 pc. 109612 bolt ISO 4014 M24 x 130-8.8, galv.  
1 pc. 130342 nut ISO 7042 M24-8, galv.

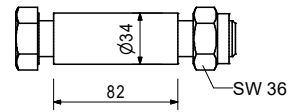
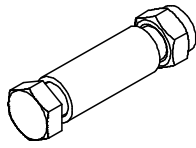

123509	13.400
--------	--------

**Cross Connector RCS**  
For crosswise connection of Climbing Rails RCS.

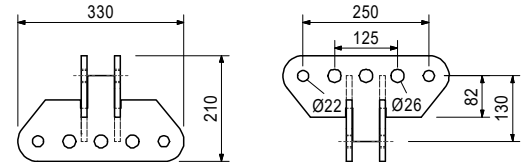
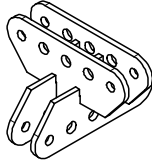

Accessories

104031	0.462	<b>Fitting pin Ø 21 x 120</b>
018060	0.014	<b>Cotter pin 4/1, galv.</b>
111567	0.729	<b>Fitting pin Ø 26 x 120</b>
022230	0.033	<b>Cotter pin 5/1, galv.</b>

# VGW Cantilevered Parapet Carriage

Article no. Weight kg

Article no.	Weight kg	Steel Waler Universal SRU U120
103868	18.100	Steel Waler Universal SRU U120, L = 0.72 m
103871	24.200	Steel Waler Universal SRU U120, L = 0.97 m
123809	29.500	Steel Waler Universal SRU U120, L = 1.17 m
103874	30.900	Steel Waler Universal SRU U120, L = 1.22 m
103877	38.100	Steel Waler Universal SRU U120, L = 1.47 m
103886	44.700	Steel Waler Universal SRU U120, L = 1.72 m
125088	46.100	Steel Waler Universal SRU U120, L = 1.77 m
103889	52.000	Steel Waler Universal SRU U120, L = 1.97 m
103898	58.600	Steel Waler Universal SRU U120, L = 2.22 m
123812	63.000	Steel Waler Universal SRU U120, L = 2.37 m
103892	65.600	Steel Waler Universal SRU U120, L = 2.47 m
103929	72.000	Steel Waler Universal SRU U120, L = 2.72 m
103903	81.000	Steel Waler Universal SRU U120, L = 2.97 m
103906	92.600	Steel Waler Universal SRU U120, L = 3.47 m
103915	106.000	Steel Waler Universal SRU U120, L = 3.97 m
103918	119.000	Steel Waler Universal SRU U120, L = 4.47 m
103922	135.000	Steel Waler Universal SRU U120, L = 4.97 m
103925	146.000	Steel Waler Universal SRU U120, L = 5.47 m
103928	159.000	Steel Waler Universal SRU U120, L = 5.97 m

Universal Steel Waler Profile U120 used as waling for girder wall formwork and for various special applications. With adjustable spacers.

L
722
972
1,172
1,222
1,472
1,722
1,772
1,972
2,222
2,372
2,472
2,722
2,972
3,472
3,972
4,472
4,972
5,472
5,972

**Note**

Permissible load: see PERI Design Tables!

**Technical data**

U120:  $W_y = 121.4 \text{ cm}^3$ ,  $I_y = 728 \text{ cm}^4$ .

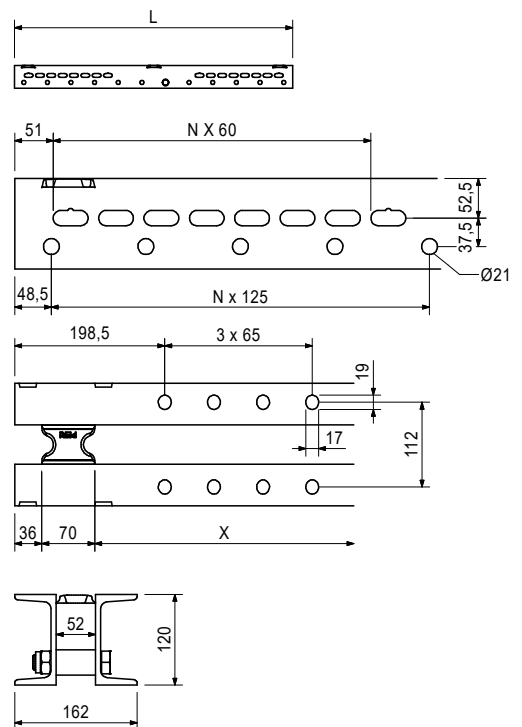
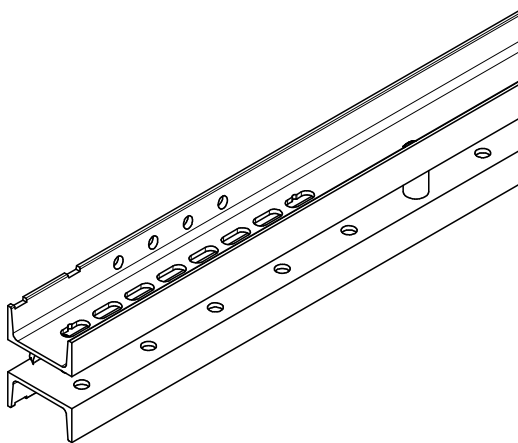

# VGW Cantilevered Parapet Carriage

Article no.	Weight kg
104027	7.610

**Extension VARIO 24 U120**  
For assembling on Steel Waler SRU.

**Complete with**  
4 pc. 710252 bolt ISO 4017 M16 x 50-8.8, galv.  
4 pc. 104024 nut ISO 7040 M16-8, galv.  
4 pc. 710880 washer DIN 434 18, galv.

**Technical data**  
U120:  $W_y = 121.4 \text{ cm}^3$ ,  $I_y = 728 \text{ cm}^4$ .

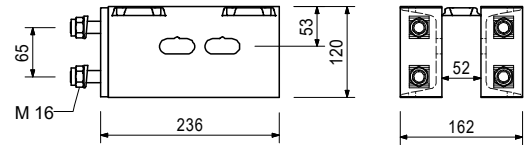
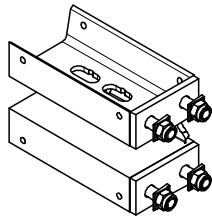

111035	12.000
101773	15.300
101774	18.300
101776	24.900
101778	32.300
101779	38.500
109726	44.800
109785	51.000

**Heavy-Duty Spindles SLS**  
**Heavy-Duty Spindle SLS 40/80**  
**Heavy-Duty Spindle SLS 80/140**  
**Heavy-Duty Spindle SLS 100/180**  
**Heavy-Duty Spindle SLS 140/240**  
**Heavy-Duty Spindle SLS 200/300**  
**Heavy-Duty Spindle SLS 260/360**  
**Heavy-Duty Spindle SLS 320/420**  
**Heavy-Duty Spindle SLS 380/480**

Used as adjustable spindle for truss beams made of Steel Walers SRU and Climbing Rails RCS.

A	min. L	max. L
344	400	800
746	800	1,400
946	1,000	1,800
1,346	1,400	2,400
1,944	2,000	3,000
2,544	2,600	3,600
3,144	3,200	4,200
3,744	3,800	4,800

**Note**  
See PERI Design Tables for permissible load.

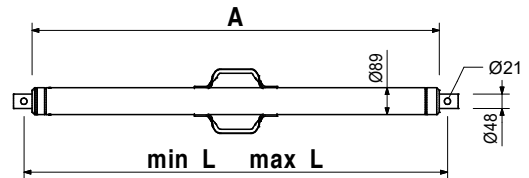
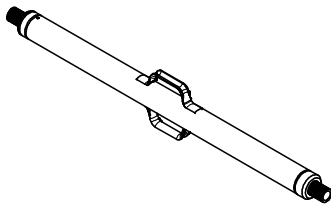

104031	0.462
018060	0.014
110477	3.990
129695	0.028

Accessories  
**Fitting pin Ø 21 x 120**  
**Cotter pin 4/1, galv.**  
**Spindle Adapter SLS/RCS**  
**Reducing Bushing Ø 26 - 21, galv.**

110477	3.990
--------	-------

**Spindle Adapter SLS/RCS**  
For connecting Heavy-Duty Spindles SLS to the Climbing Rail RCS.

**Complete with**  
1 pc. 104031 fitting pin Ø 21 x 120  
1 pc. 018060 cotter pin 4/1, galv.

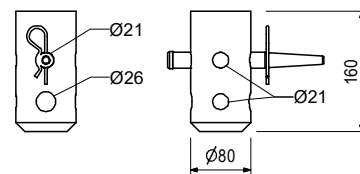
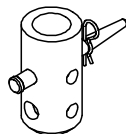

104031	0.462
018060	0.014
111567	0.729
022230	0.033

Accessories  
**Fitting pin Ø 21 x 120**  
**Cotter pin 4/1, galv.**  
**Fitting pin Ø 26 x 120**  
**Cotter pin 5/1, galv.**

# VGW Cantilevered Parapet Carriage

Article no.	Weight kg
104031	0.462

**Fitting pin Ø 21 x 120**  
For various connections.

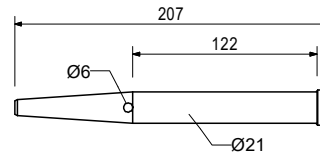
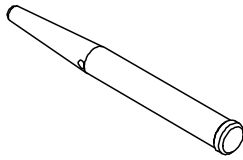

Accessories

018060	0.014
--------	-------

**Cotter pin 4/1, galv.**

018060	0.014
--------	-------

**Cotter pin 4/1, galv.**



110012	23.500
--------	--------

**Diagonal Strut RCS 212**

For bracing of RCS Framework Brackets.

**Complete with**

- 1 pc. 710894 bolt Ø 25 x 180, geomet.
- 1 pc. 018060 cotter pin 4/1, galv.
- 2 pc. 109612 bolt ISO 4014 M24 x 130-8.8, galv.
- 1 pc. 105032 nut ISO 7040 M24-8, galv.

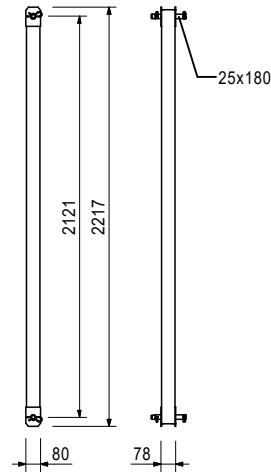
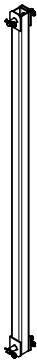



# VGW Cantilevered Parapet Carriage

Article no.	Weight kg
103737	10.800

## Universal Coupling UK 70

For rigid connection of Steel Walers SRU and for connecting Heavy-Duty Spindles SLS.

### Note

See PERI Design Tables for permissible load.

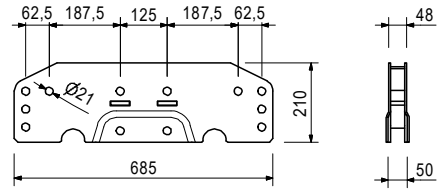
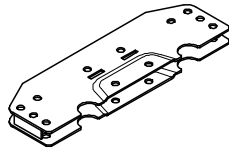

### Accessories

104031	0.462
018060	0.014

**Fitting pin Ø 21 x 120**  
**Cotter pin 4/1, galv.**

111279	2.450
--------	-------

## Cross Connector VARIOKIT

For right-angled connection of Steel Walers SRU to SRU or of Steel Walers SRU to RCS.

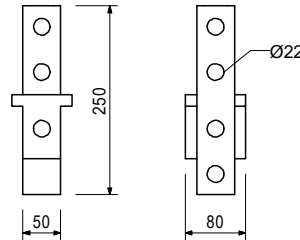
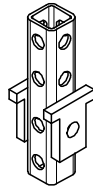

### Accessories

104031	0.462
018060	0.014

**Fitting pin Ø 21 x 120**  
**Cotter pin 4/1, galv.**

111283	9.950
--------	-------

## Elbow Connection RCS/SRU

For right-angled connection of Steel Walers SRU to Climbing Rails RCS and assembling guardrail posts to Steel Walers SRU.

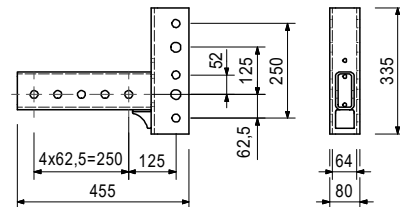
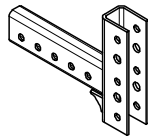

### Accessories

104031	0.462
018060	0.014
111567	0.729
022230	0.033

**Fitting pin Ø 21 x 120**  
**Cotter pin 4/1, galv.**  
**Fitting pin Ø 26 x 120**  
**Cotter pin 5/1, galv.**

# VGW Cantilevered Parapet Carriage

Article no.	Weight kg
123497	15.700

## Spindle Bracket VARIOKIT

For connecting the Heavy-Duty Spindle SLS to the Climbing Rail RCS with minimal spindle inclination.

### Complete with

3 pc. 104031 fitting pin  $\varnothing$  21 x 120  
3 pc. 018060 cotter pin 4/1, galv.

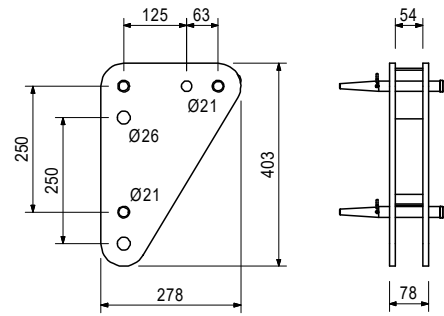
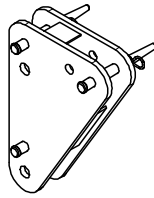

123513	37.800
--------	--------

## Slide Connector VARIOKIT

For right-angled and slidable T-connection of Climbing Rails RCS.

### Complete with

1 pc. 104031 fitting pin  $\varnothing$  21 x 120  
1 pc. 018060 cotter pin 4/1, galv.

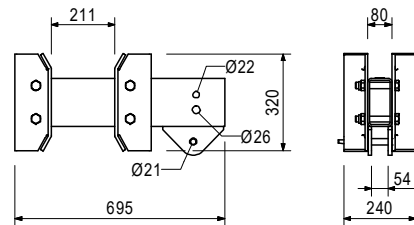
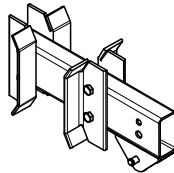

113933	17.400
--------	--------

## Adjusting Unit VARIOKIT

As an articulated joint for SRZ and SRU Steel Walers. With integrated adjustment.

### Complete with

3 pc. 104031 fitting pin  $\varnothing$  21 x 120  
3 pc. 018060 cotter pin 4/1, galv.

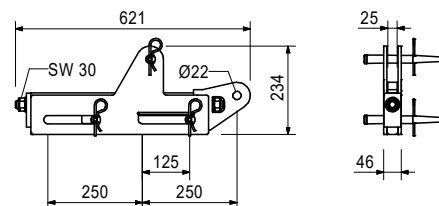
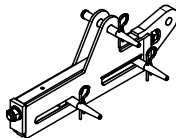

Accessories

104031	0.462
018060	0.014

**Fitting pin  $\varnothing$  21 x 120**

**Cotter pin 4/1, galv.**

117425	7.090
--------	-------

## Cross connector VST

For connecting Horizontal Ledgers VST and Diagonal Bracing VST perpendicular to the frame plane.

### Complete with

2 pc. 113994 bolt ISO 4014 M20 x 140-8.8, galv.  
2 pc. 781053 nut ISO 7040 M20-8, galv.  
1 pc. 117492 sleeve VST, galv.

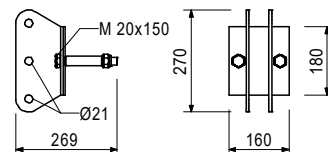
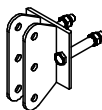

Article no.	Weight kg
117411	18.600

## Bracing connector VST

For connecting Horizontal Ledgers VST and Diagonal Bracing VST in frame plane.

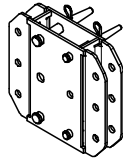

## Complete with

- 2 pc. 104031 fitting pin  $\varnothing$  21 x 120
- 2 pc. 111567 fitting pin  $\varnothing$  26 x 120
- 2 pc. 018060 cotter pin 4/1, galv.
- 2 pc. 022230 cotter pin 5/1, galv.

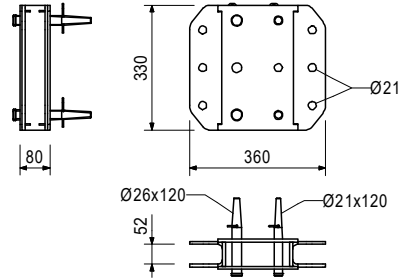

115623	5.040
--------	-------

## Corner Connector SRU VARIOKIT

For rigid connection of Steel Walers SRU.

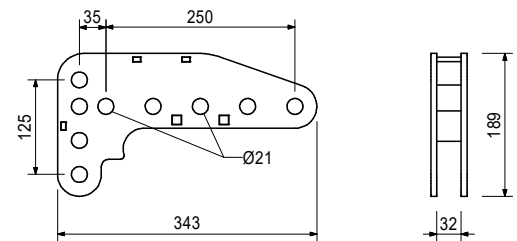
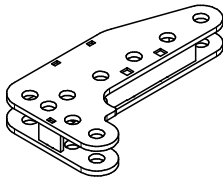

Accessories

104031	0.462
018060	0.014

**Fitting pin  $\varnothing$  21 x 120**

**Cotter pin 4/1, galv.**

111274	13.600
--------	--------

## Heavy-Duty Roller Gear Connection VARIOKIT

For connecting Heavy-Duty Roller Gears 150 kN, Item no. 022040 and 200 kN, Art. no. 022041 to Steel Walers SRU.

## Complete with

- 4 pc. 721817 bolt ISO 4014 M12 x 50-8.8, galv.
- 4 pc. 710381 nut ISO 7040 M12-8, galv.
- 4 pc. 780702 washer ISO 7089 200 HV, A12, galv.
- 2 pc. 710226 bolt ISO 4014 M20 x 90-8.8, galv.
- 2 pc. 781053 nut ISO 7040 M20-8, galv.

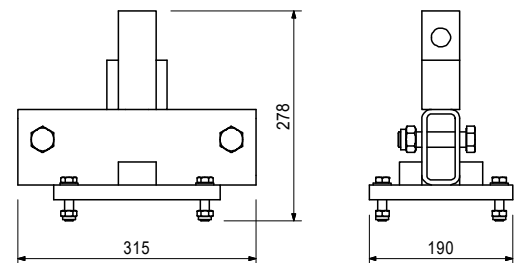
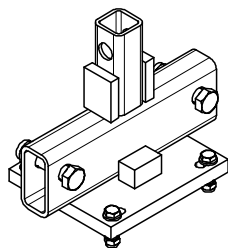

# VGW Cantilevered Parapet Carriage

Article no.	Weight kg
022040	8.400

## Heavy-Duty Roller Gear 150 kN, series B-II

Moving device for special and heavy-duty constructions.

### Technical data

Permissible load-bearing capacity 150 kN.

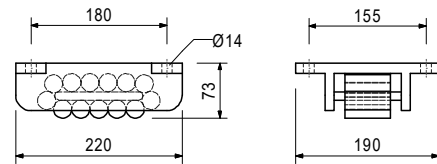
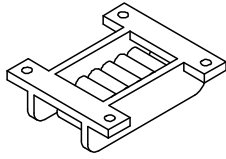

022041	11.700
--------	--------

## Heavy-Duty Roller Gear 200 kN, series A-II

Moving device for special and heavy-duty constructions.

### Technical data

Permissible load-bearing capacity 200 kN.

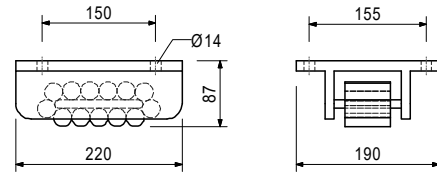
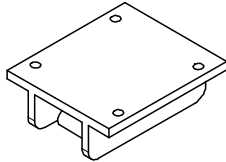

123534	5.910
--------	-------

## Bracing Connector RCS DW 15/M20

For connecting bracing with Tie Rod DW 15 and a compression brace to the Climbing Rail RCS.

### Complete with

2 pc. 710894 bolt Ø 25 x 180, geomet.  
4 pc. 018060 cotter pin 4/1, galv.

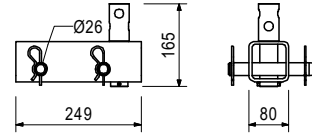
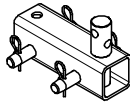

117766	4.450
--------	-------

## Bracing Connector SRU/DW 15

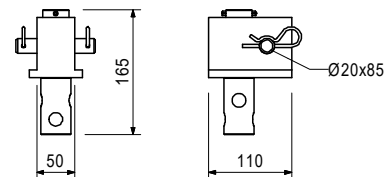
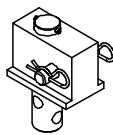

Article no. Weight kg

Article no.	Weight kg	Description
030030	1.440	<b>Tie Rod DW 15</b>
030050	0.000	<b>Tie Rod DW 15, special length</b>
030005	0.720	<b>Cutting costs DW 15, B 15</b>
030010	0.720	<b>Tie Rod DW 15, L = 0.50 m</b>
030480	1.230	<b>Tie Rod DW 15, L = 0.85 m</b>
030480	1.440	<b>Tie Rod DW 15, L = 1.00 m</b>
030490	1.730	<b>Tie Rod DW 15, L = 1.20 m</b>
030170	2.160	<b>Tie Rod DW 15, L = 1.50 m</b>
030020	2.450	<b>Tie Rod DW 15, L = 1.70 m</b>
030180	2.880	<b>Tie Rod DW 15, L = 2.00 m</b>
030710	3.600	<b>Tie Rod DW 15, L = 2.50 m</b>
030720	4.320	<b>Tie Rod DW 15, L = 3.00 m</b>
030730	5.040	<b>Tie Rod DW 15, L = 3.50 m</b>
030160	8.640	<b>Tie Rod DW 15, L = 6.00 m</b>

**Note**

Non-weldable! Observe the permissions!

**Technical data**

Permissible tension force 90 kN.

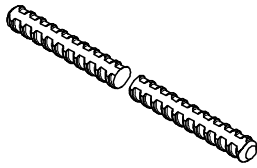

030130 0.318

**Cam nut DW 15, galv.**

For anchoring with Tie Rod DW 15 and B 15.

**Technical data**

Permissible load 90 kN.

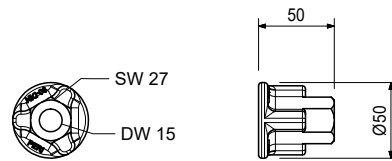
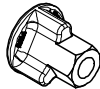

030110 0.799

**Wingnut Counterplate DW 15, galv.**

For anchoring with Tie Rod DW 15 and B 15.

**Technical data**

Permissible load 90 kN.

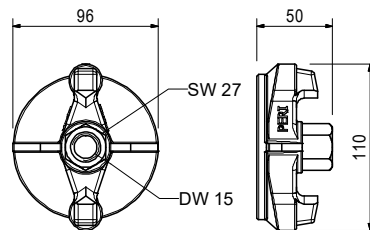

Article no.	Weight kg
030100	0.439

### Wing nut DW 15, galv.

For anchoring with Tie Rod DW 15 and B 15.

### Technical data

Permissible load 90 kN.

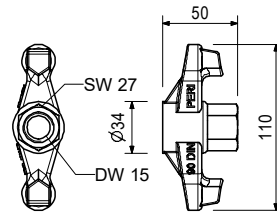

030370	1.660
--------	-------

### Wingnut Pivot Plate DW 15, galv.

For anchoring with Tie Rod DW 15 and B 15.  
With articulated, captive nut. Maximum inclination of tie: 8°.

### Note

Wrench size AF 27.

### Technical data

Permissible load 90 kN.

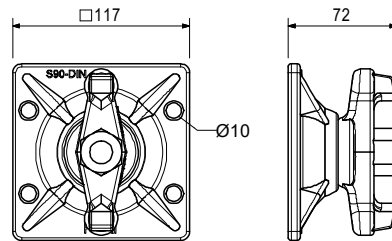
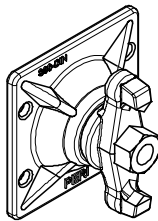

030070	0.222
--------	-------

### Hex. Nut DW 15 AF 30/50, galv.

For anchoring with Tie Rod DW 15 and B 15.

### Technical data

Permissible load 90 kN.

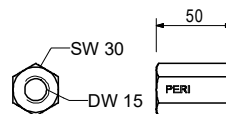

030550	0.233
--------	-------

### Hex. Nut DW 15 AF 30/50, weldable

For anchoring with Tie Rod DW 15 and B 15.

### Note

Weldable!

### Technical data

Permissible load 90 kN.

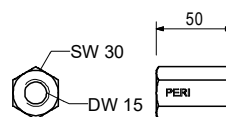

# VGW Cantilevered Parapet Carriage

Article no.	Weight kg
030090	0.402

**Hex. Nut DW 15 AF 30/108, galv.**  
For coupling Tie Rod DW 15 and B 15.

**Technical data**  
Permissible load 90 kN.

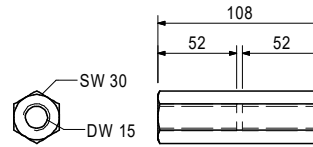
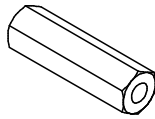

		<b>Steel scaffolding tubes Ø 48.3</b>	<b>L</b>
026415	3.550	<b>Steel scaffolding tube Ø 48.3 x 3.2, special length</b>	
026417	0.000		
026411	3.550	<b>Cutting costs for scaffolding tubes</b>	1,000
026412	7.100	<b>Steel scaffolding tube Ø 48.3 x 3.2, L = 1.0 m</b>	2,000
125976	8.900	<b>Steel scaffolding tube Ø 48.3 x 3.2, L = 2.0 m</b>	2,500
026413	10.650	<b>Steel scaffolding tube Ø 48.3 x 3.2, L = 2.5 m</b>	3,000
114287	12.500	<b>Steel scaffolding tube Ø 48.3 x 3.2, L = 3.0 m</b>	3,500
026414	14.200	<b>Steel scaffolding tube Ø 48.3 x 3.2, L = 3.5 m</b>	4,000
026419	17.750	<b>Steel scaffolding tube Ø 48.3 x 3.2, L = 4.0 m</b>	5,000
026418	21.600	<b>Steel scaffolding tube Ø 48.3 x 3.2, L = 5.0 m</b>	6,000
		<b>Steel scaffolding tube Ø 48.3 x 3.2, L = 6.0 m</b>	

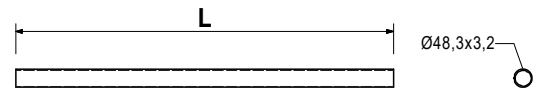
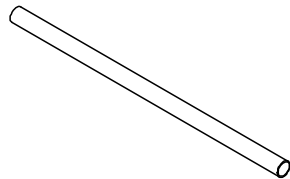

017010	1.400
--------	-------

**Swivel Coupling AF 48/48, galv.**  
For scaffolding tubes Ø 48 mm.

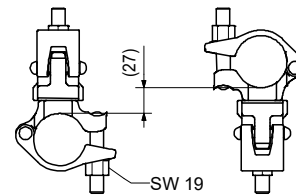
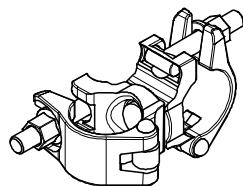

017020	1.120
--------	-------

**Standard Coupler RA 48/48, galv.**  
For scaffolding tubes Ø 48 mm.

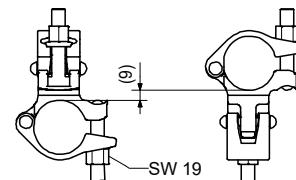
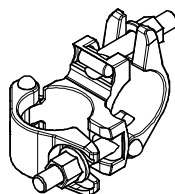

# VGW Cantilevered Parapet Carriage

Article no.	Weight kg
110296	0.220

**Clamp A64 DIN 3570 M12, galv.**  
For fitting scaffolding tubes  $\varnothing$  48 or  $\varnothing$  60.

**Note**  
Wrench size AF 19.

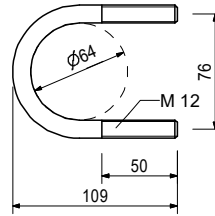
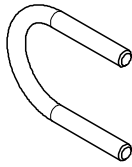

Accessories

710330	0.017
--------	-------

**Nut ISO 4032 M12-8, galv.**

110084	2.510
--------	-------

**Scaffold Tube Holder  $\varnothing$  48 RCS**  
For fitting scaffolding tubes  $\varnothing$  48 mm to Climbing Rails RCS.

**Complete with**  
1 pc. 017040 Screw-On Coupler AK 48, galv.  
1 pc. 710894 bolt  $\varnothing$  25 x 180, geomet.  
2 pc. 018060 cotter pin 4/1, galv.

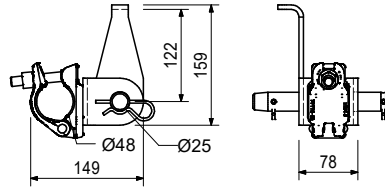

103945	1.840
--------	-------

**Scaffold Tube Connector FTF**  
For connecting scaffolding tubes to Steel Walers SRU.

**Complete with**  
2 pc. 105822 bolt  $\varnothing$  20 x 102, galv.  
2 pc. 018060 cotter pin 4/1, galv.

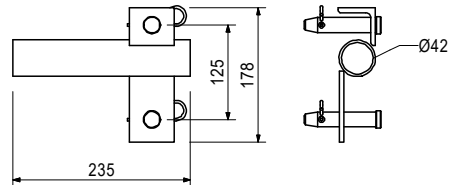
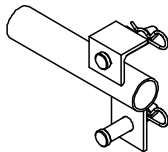

130045	1.670
--------	-------

**Scaffold Tube Adapter  $\varnothing$  48 Alpha**

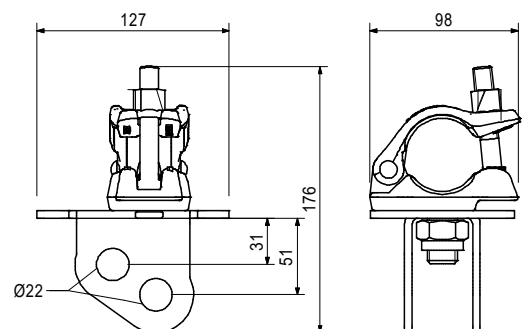
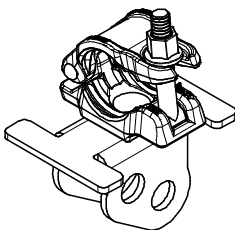



# VGW Cantilevered Parapet Carriage

Article no.	Weight kg
109720	26.600

## Guardrail Post RCS 226

For fitting guardrails onto the main platform for Formwork Scaffold RCS or used as horizontal strut for bracing.

### Complete with

2 pc. 104477 bolt ISO 4014 M20 x 120-8.8, galv.  
2 pc. 781053 nut ISO 7040 M20-8, galv.

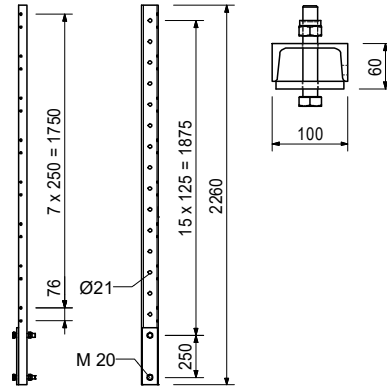

109721	40.700
--------	--------

## Guardrail Post RCS 384

For assembling guardrails onto the intermediate and finishing platforms for RCS Formwork Scaffoldings or used as horizontal strut for bracing.

### Complete with

1 pc. 104477 bolt ISO 4014 M20 x 120-8.8, galv.  
1 pc. 781053 nut ISO 7040 M20-8, galv.

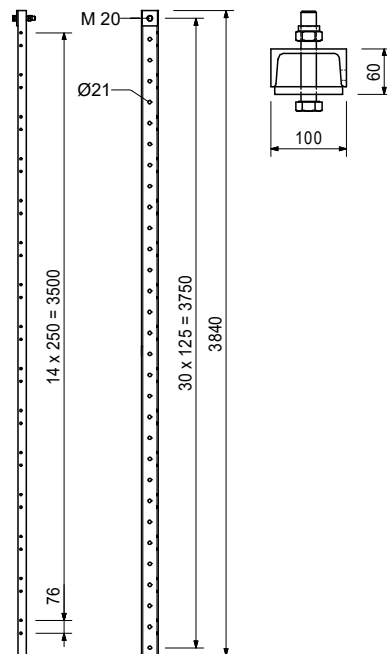

Article no.	Weight kg
126088	4.390

## Guardrail Post Holder Multi

For fixing of an end guardrail post on Platform Beams GT 24, VT 20 or Timbers 80/160. Fixing of the guardrail posts by means of hex. bolts M20 or clamps A64.

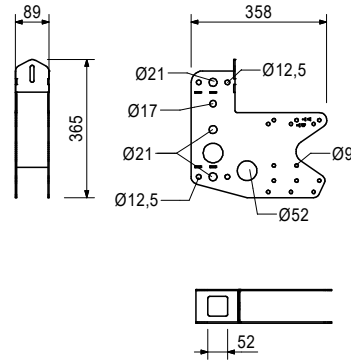
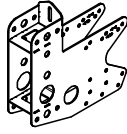

Accessories	
710285	0.050
024090	0.005
024470	0.008

### Accessories

**Bolt ISO 4014 M8 x 100-8.8, galv.**

**Nut ISO 4032 M8-8, galv.**

**TSS-Torx 6 x 60, galv.**

114328	16.600
--------	--------

## Guardrail Post RCS/SRU 184

For fitting guardrails onto Platform Beam RCS/SRU or Elbow Connection RCS/SRU.

### Complete with

2 pc. 114727 bolt ISO 4017 M20 x 100-8.8, galv.

2 pc. 781053 nut ISO 7040 M20-8, galv.

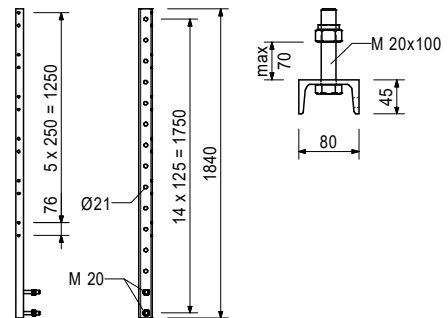

Accessories	
110296	0.220
710330	0.017

### Accessories

**Clamp A64 DIN 3570 M12, galv.**

**Nut ISO 4032 M12-8, galv.**

116363	0.089
--------	-------

## Spacer RCS 184

Compensation between Angle Connector RCS/SRU and Guardrail Post RCS 184.



# VGW Cantilevered Parapet Carriage

Article no.	Weight kg
101290	5.670

## Guardrail Holder GT 24/VT 20

For fitting a guardrail onto Girder GT 24 and VT 20.

## Complete with

1 pc. 105400 bolt  $\varnothing$  20 x 140, galv.

1 pc. 018060 cotter pin 4/1, galv.

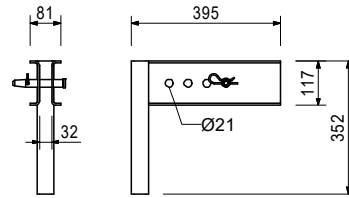
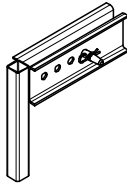

Accessories

116292	4.720
061260	6.150

## Guardrail Post HSGP-2

## Guardrail Post SGP

061260	6.150
--------	-------

## Guardrail Post SGP

As guardrails for various systems.

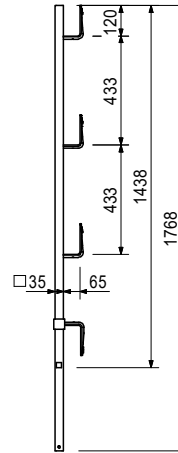

114299	9.520
--------	-------

## Guardrail Post GKB

To be clamped onto the reinforcement or fixed to built-in parts.

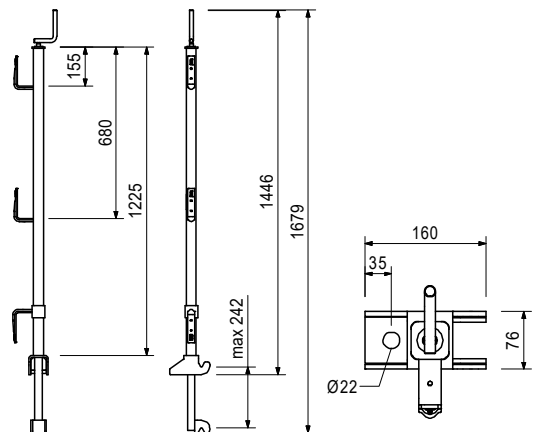

# VGW Cantilevered Parapet Carriage

Article no.	Weight kg
117325	4.270

**Post PP**  
For fixing the side mesh barrier.

**Technical data**  
Maximum post spacing with side mesh barrier:  
PMB 260 max. 2.40 m.

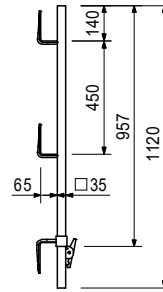

117323	1.530
--------	-------

**Slab Foot PDF**  
For fitting a guardrail onto slab edges.

**Technical data**  
Maximum post spacing with side mesh barrier:  
PMB 260 max. 2.40 m.

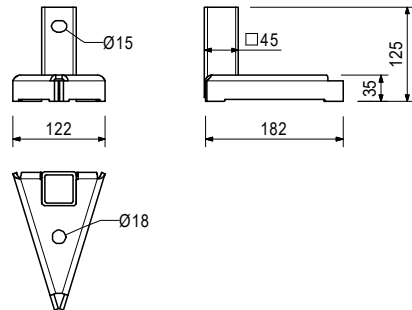
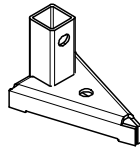

Accessories  
117020 0.213 **PERI Tie Bolt 14 x 150**  
117325 4.270 **Post PP**

117020	0.213
117325	4.270

057083 3.820 **Diagonal Bracing DW 15 ACS**  
For bracing in order to improve rigidity of scaffolds. For bracing large VARIO GT 24 elements.

**Complete with**  
2 pc. 024910 bolt ISO 4014 M20 x 100-8.8, galv.  
2 pc. 710334 nut ISO 4032 M20-8, galv.

**Note**  
Tie Rod DW 15 must be ordered separately.

**Technical data**  
Permissible tension force 35 kN.

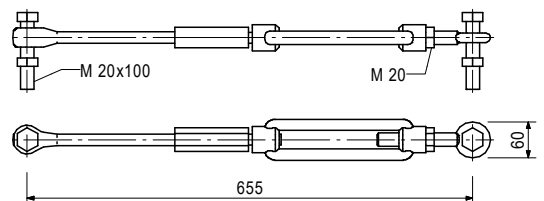
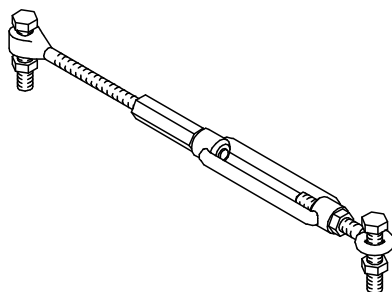

Accessories  
030030 1.440 **Tie Rod DW 15, special length**  
030050 0.000 **Cutting costs DW 15, B 15**

030030	1.440
030050	0.000

# VGW Cantilevered Parapet Carriage

Article no.	Weight kg
102018	4.880

**Base Plate-2 for RS 1000/1400, galv.**  
 For fitting the Push-Pull Props RS 210, 260, 300, 450, 650, 1000, 1400 and heavy-duty spindles.

**Complete with**  
 2 pc. 105400 bolt  $\varnothing$  20 x 140, galv.  
 2 pc. 018060 cotter pin 4/1, galv.

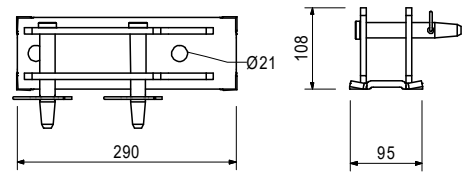
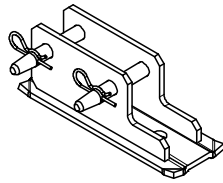

110290	5.030
--------	-------

**Squared Timber Adapter RCS 12/20**  
 For fitting squared timbers onto the Climbing Rails RCS when used as a climbing protection panel.

**Complete with**  
 1 pc. 110281 Eyebolt M20, right, galv.  
 1 pc. 781053 nut ISO 7040 M20-8, galv.

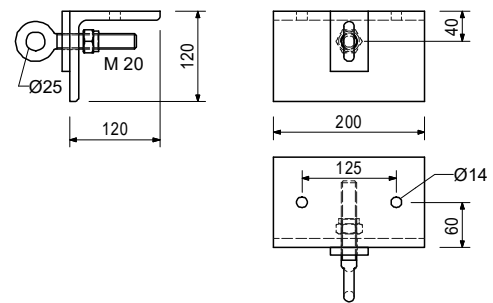
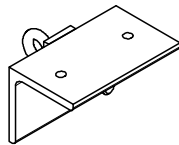

## Accessories

070030	0.015	<b>Plate Connector <math>\varnothing</math> 48/12 mm, single-sided</b>
018330	0.140	<b>Bolt ISO 4016 M12 x 140-4.6 MU, galv.</b>
027340	0.180	<b>Bolt ISO 4016 M12 x 180-4.6 MU, galv.</b>
113348	0.043	<b>Washer ISO 7094 100 HV, A 12, galv.</b>

114997	7.160
--------	-------

**Bracing Shoe RCS DW 15**  
 For anchoring bracing with DW 15 to the structure. Tie System M24 or appropriate dowels to be used during assembly.

**Complete with**  
 1 pc. 104031 fitting pin  $\varnothing$  21 x 120  
 1 pc. 018060 cotter pin 4/1, galv.

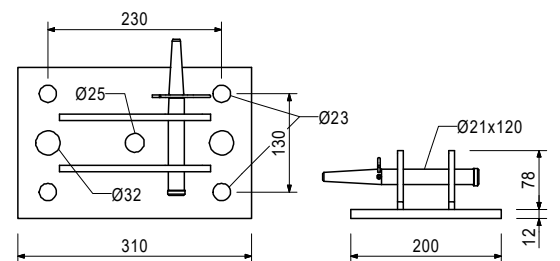
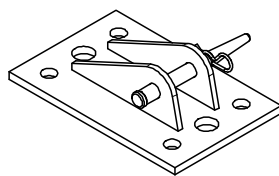

105395	0.330
--------	-------

**Bolt 20 x 140 rough**

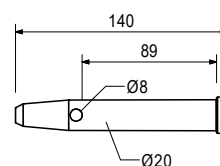
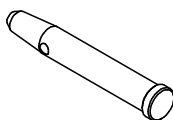

# VGW Cantilevered Parapet Carriage

Article no. Weight kg

710252 0.100 **Bolt ISO 4017 M16 x 50-8.8, galv.**

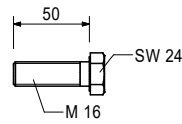

710880 0.032 **Washer DIN 434 18, galv.**

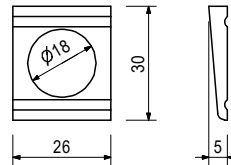
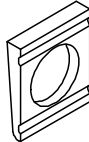

070890 0.030 **Nut ISO 7040 M16-8, galv.**  
Self-locking.

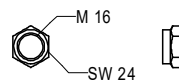

104477 0.300 **Bolt ISO 4014 M20 x 120-8.8, galv.**

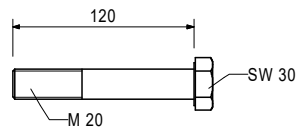
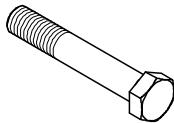

Accessories

781053 0.065 **Nut ISO 7040 M20-8, galv.**

781053 0.065 **Nut ISO 7040 M20-8, galv.**  
Self-locking.

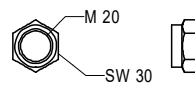

126228 0.030 **F.H. Bolt DIN 603 M8 x 70, galv.**

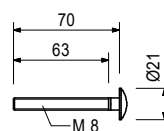

Article no.	Weight kg
711071	0.004

**Nut ISO 7040 M8-8, galv.**  
Self-locking.



123970	0.047
--------	-------

**PERI Screw-On Sleeve M16/164**  
For temporary assembly of components on reinforced concrete slabs.

**Note**  
After concreting has taken place, it is inserted in the fresh concrete.

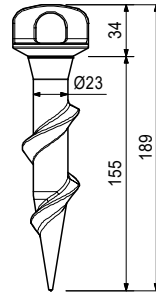
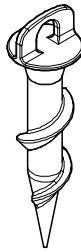

Accessories

123973	0.240
--------	-------

**Bolt ISO 4017 M16 x 130-8.8, galv.**

117020	0.213
--------	-------

**PERI Tie Bolt 14 x 150**  
Re-usable.  
Technical Approval available (see Z-21.8-1916).

**Note**  
Separate structural design information on request.

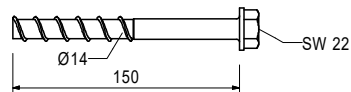
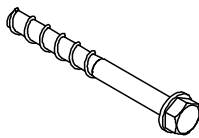

123973	0.240
--------	-------

**Bolt ISO 4017 M16 x 130-8.8, galv.**  
Used in connection with the PERI Screw-On Sleeve M16/164 for assembling the Slab Foot PDF.

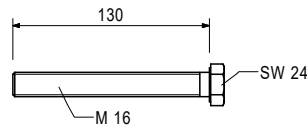
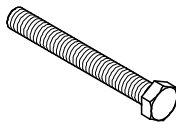

105402	0.200
--------	-------

**Bolt ISO 4014 M16 x 120-8.8, galv.**

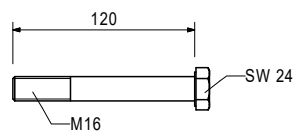
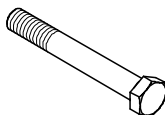

# VGW Cantilevered Parapet Carriage

Article no.	Weight kg
113349	0.087

**Washer ISO 7094 100 HV, A16, galv.**

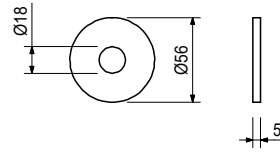

111567	0.729
--------	-------

**Fitting pin Ø 26 x 120**  
For various connections.

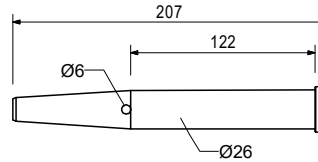
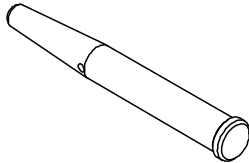

022230	0.033
--------	-------

Accessories  
**Cotter pin 5/1, galv.**

022230	0.033
--------	-------

**Cotter pin 5/1, galv.**

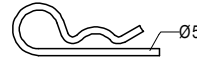

051761	13.700
--------	--------

**Tool Set ACS**

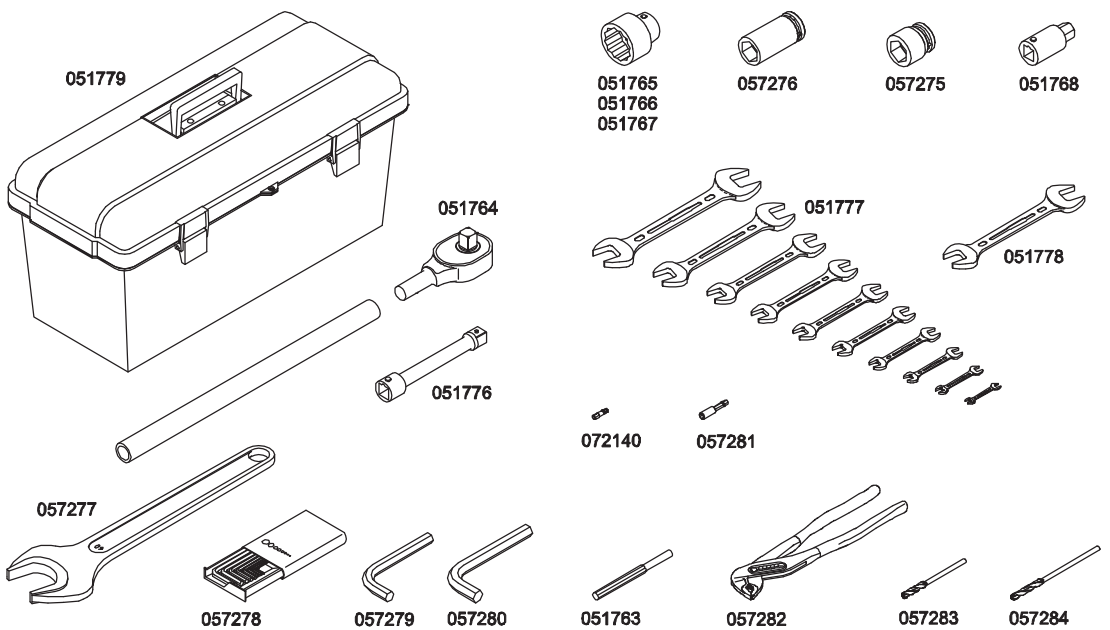



# VGW Cantilevered Parapet Carriage

Article no.	Weight kg
065068	88.300

**Crate Pallet 80 x 120-K, galv.**  
 For stacking and transporting formwork and scaffold components.

**Note**  
 Follow the instructions for use!  
**Technical data**  
 Capacity approx. 0.75 m<sup>3</sup>.  
 Permissible load-bearing capacity 1.5 t.

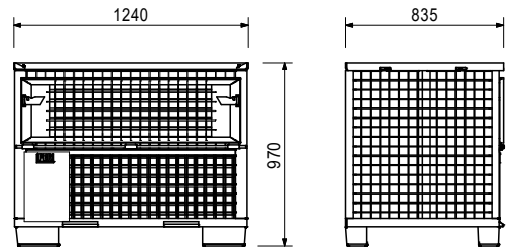
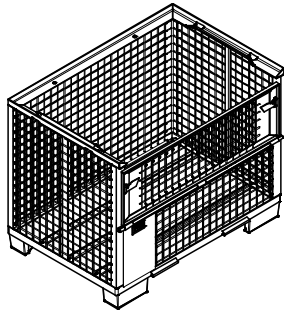

103434	38.500
103429	45.300

**Pallets RP-2**  
**Pallet RP-2 80 x 120, galv.**  
**Pallet RP-2 80 x 150, galv.**  
 For stacking and transporting formwork and scaffold components.

**Note**  
 Follow the instructions for use!  
**Technical data**  
 Permissible load-bearing capacity 1.5 t.

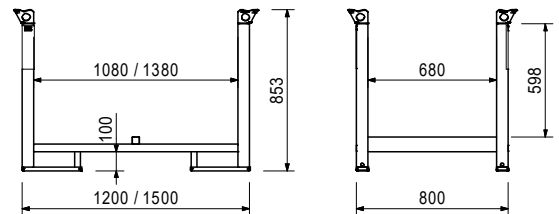
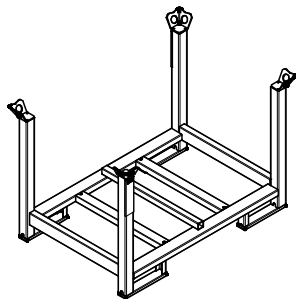

025660	66.500
--------	--------

**Hardware Box 80 x 120, galv.**  
 For stacking and transporting formwork and scaffold components.

**Note**  
 Follow the instructions for use!  
**Technical data**  
 Capacity approx. 0.28 m<sup>3</sup>.  
 Permissible load-bearing capacity 1.5 t.

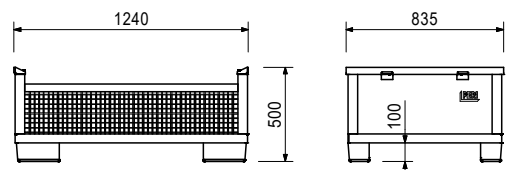
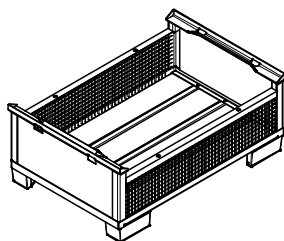





The optimal system  
for all projects and  
every requirement



Wall formwork



Column formwork



Slab formwork



Climbing systems



Bridge formwork



Tunnel formwork



Shoring



Working scaffolds construction



Working scaffolds facade



Working scaffolds industry



Means of access



Safety scaffolds



Safety systems



System-independent accessories



Services



**PERI SE**  
Formwork Scaffolding Engineering  
Rudolf-Diesel-Strasse 19  
**89264 Weissenhorn**  
Germany  
Telephone +49 (0)7309.950-0  
Fax +49 (0)7309.951-0  
info@peri.de  
www.peri.com

