

PERI ALPHADECK

Panel Slab Formwork System

Instructions for Assembly and Use – Standard Configuration – Issue 07 | 2020

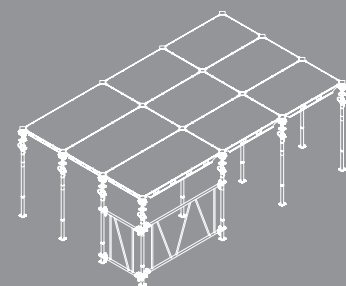

Main components

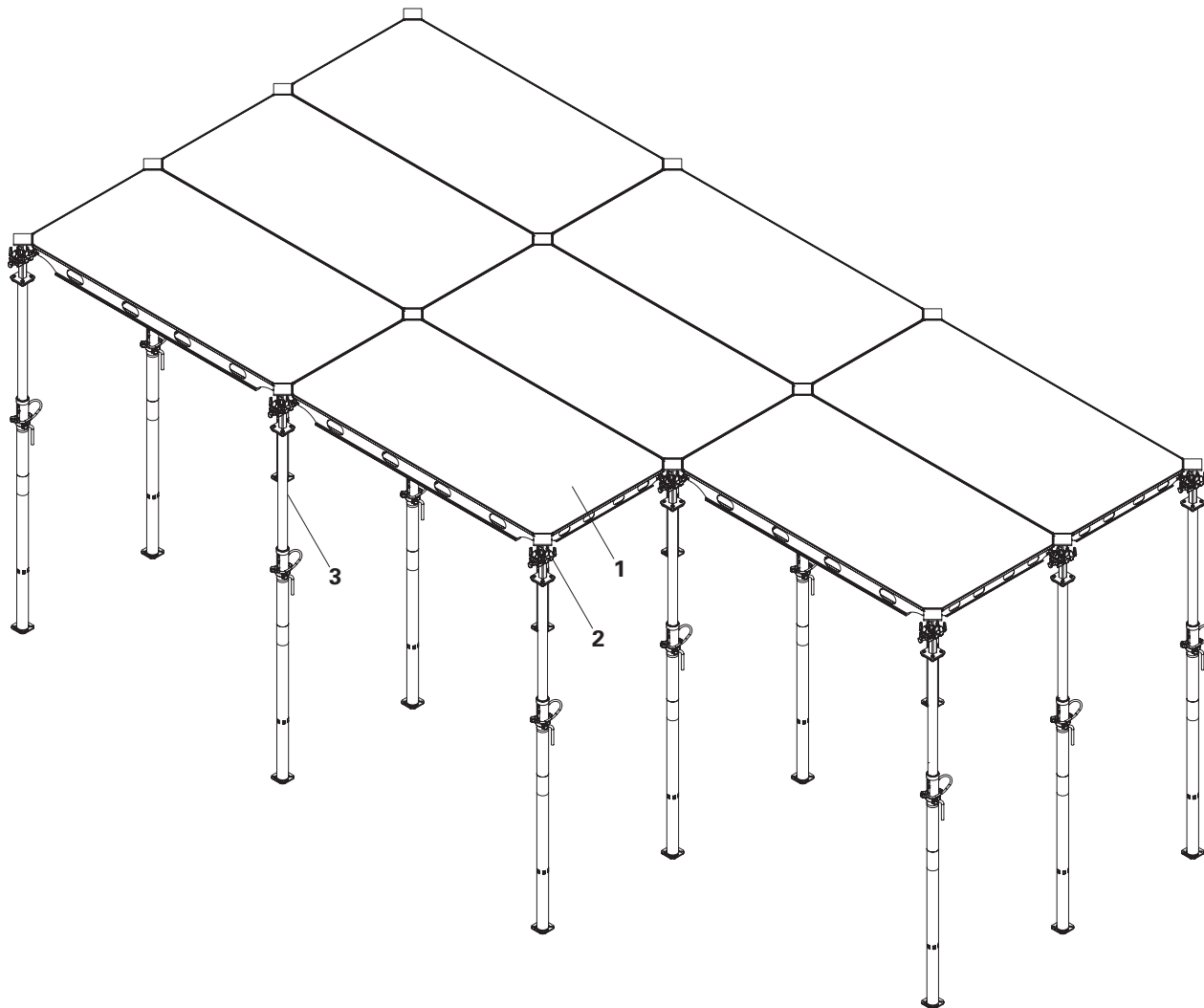

- 1 Panel ADP
- 2 Drophead ADH
- 3 Prop

Overview

| | |
|--------------------------|---|
| Main components | 1 |
| Key | 2 |
| Presentational reference | 2 |

Introduction

| | |
|---------------------------------------|---|
| Target groups | 3 |
| Additional technical documentation | 3 |
| Intended use | 4 |
| Cleaning and maintenance instructions | 5 |
| Instructions on use | 5 |

Safety instructions

| | |
|----------------------------|---|
| Cross-system | 6 |
| System-specific | 7 |
| Storage and transportation | 7 |

| | | |
|-----|--|----|
| A1 | Component overview | 8 |
| A2 | Storage and transportation | 9 |
| A3 | System components | 10 |
| | Panel ADP | 10 |
| | Drophead ADH | 11 |
| | Shuttering aid AD | 11 |
| | Slab props | 12 |
| | Bracing ADB | 13 |
| | Filler beam ADF | 13 |
| | Guardrail holder ADG with | |
| | Guardrail post HSGP-2 | 13 |
| A4 | Design information | 14 |
| | Prop loads in panel system | 15 |
| A5 | Shuttering | 16 |
| | General | 16 |
| | Starting bay | 17 |
| | Erecting the panels in shorter direction | 19 |
| | Erecting the panels in longer direction | 20 |
| | Bracing ADB Guidelines | 22 |
| A6 | Checklist | 23 |
| A7 | Infill areas | 26 |
| | Transverse and longitudinal infill | 26 |
| | Infill at corner areas | 28 |
| | Infill at wall internal corner | 29 |
| | Infill at beam internal corner | 30 |
| A8 | Shuttering around columns | 31 |
| A9 | Guardrails | 33 |
| A10 | Cantilevers | 34 |
| | Cantilever in longer direction of the panel | 34 |
| | Cantilever in shorter direction of the panel | 36 |
| A11 | Striking | 38 |
| | When early striking is required | 38 |
| | When early striking is not required | 42 |

Load charts for slab props













| | |
|------------------------------|----|
| PEP 20 | 43 |
| PEP 30 | 44 |
| PEP Ergo B | 45 |
| PEP Ergo D | 46 |
| PEP Ergo E | 48 |
| MULTIPROP 250, 350, 480, 625 | 49 |
| PEP Alpha, PEP Alpha-2 | 50 |

Components



| | |
|----------------|----|
| Component list | 51 |
|----------------|----|

Key

Pictogram | Definition

-  Danger/Warning/Caution
-  Information
-  To be complied with
-  Load-bearing point
-  Visual check
-  Tip
-  Misapplication
-  Safety helmet
-  Safety shoes
-  Safety gloves
-  Safety glasses
-  Personal protective equipment to prevent falling from a height (PPE)

Arrows

-  Arrow representing an action
-  Arrow representing a reaction of an action*
-  Forces

* If not identical to the action arrow.

Safety instruction categories

The safety instructions alert site personnel to the risks involved and provide information on how to avoid these risks. Safety instructions are featured at the beginning of the section or ahead of the instructions, and are highlighted as follows:

Danger

This sign indicates an extremely hazardous situation which, if not avoided, will result in death or serious injury.

Warning

This sign indicates a hazardous situation which, if not avoided, could result in death or serious injury.

Caution

This sign indicates a hazardous situation which, if not avoided, could result in minor or moderate injury.

Information

This sign indicates situations in which failure to observe the information can result in material damage.

Set-up of the safety instructions

Signal word

Type and source of the danger!
Consequences of non-compliance.
⇒ Avoidance measures.

Dimension specifications

Dimensions are usually given in cm. Other measurement units, e.g. m, are shown in the illustrations.

Conventions

- Instructions are numbered with:
1., 2., 3.
- The result of an instruction is shown by: →
- Position numbers are clearly provided for the individual components and are given in the drawing, e.g. **1**, in the text in brackets, for example (1).
- Multiple position numbers, i.e. alternative components, are represented with a slash: e.g. **1 / 2**.

Presentational reference

The illustration on the front cover of these instructions is understood to be a system representation only. The assembly steps presented in these Instructions for Assembly and Use are shown in the form of examples with only one component size. They are valid accordingly for all component sizes contained in the standard configuration.

For a better understanding, detailed illustrations are partly incomplete. Some safety installations which have possibly not been shown in these detailed descriptions must nevertheless still be available.

Target groups

Contractors

These Instructions for Assembly and Use are designed for contractors who use the formwork systems for

- assembling, modifying and dismantling operations, or
- use them, e.g. for concreting, or
- allow them to be used for other work operations, e.g. carpentry or electrical work.

Construction site coordinator

The Safety and Health Coordinator*

- is appointed by the client,
- must identify potential hazards during the planning phase,
- determines measures that provide protection against risks,
- creates a safety and health plan,
- coordinates the protective measures for the contractor and site personnel so that they do not endanger each other,
- monitors compliance with the protective measures.

Competent persons

Due to the specialist knowledge gained from professional training, work experience and recent professional activity, the competent person has a reliable understanding of safety-related issues and can correctly carry out inspections. Depending on the complexity of the test to be undertaken, e.g. scope of testing, type of testing or the use of a certain measuring device, a range of specialist knowledge is necessary.

Qualified persons

Formwork systems may only be assembled, modified or dismantled by a competent person.

For the work to be carried out, the qualified persons must have received instructions** covering at least the following points:

- Explanation of the plan for the assembly, modification or dismantling of the formwork in an understandable form and language.
- Description of the measures for assembling, modifying or dismantling the formwork.
- Designation of the preventive measures to avoid the risk of persons and objects falling.

- Designation of the safety precautions in the event of changing weather conditions which could adversely affect the safety of the formwork system as well as the persons concerned.
- Details regarding the permissible loads.
- Description of any other risks that are associated with the assembly, modification or dismantling procedures.



- **In other countries, ensure that the relevant national guidelines and regulations in the respective current version are complied with!**
- **If no country-specific regulations are available, it is recommended to proceed according to German rules and regulations.**
- **A competent person must be present on site during formwork operations.**

* Valid in Germany: Regulations for Occupational Health and Safety on Construction Sites 30 (RAB 30)

** Instructions are given by the contractor himself or a competent person selected by him.

Additional technical documentation

- Brochure/Flyer:
 - ALPHADECK
- Instructions for Assembly and Use
 - MULTIPROP Slab Props
 - PEP Ergo Slab Props
 - PEP Alpha and Alpha-2 Props
- Instructions for Use
 - Pallets and Stacking Devices
 - Pallet Lifting Trolley
 - PERI Bio Clean
- Data Sheet: Anchor Bolt PERI 14/20 x 130
- Design Tables 2015 – Formwork and Shoring

Intended use

Product description

PERI products have been designed for exclusive use in the industrial and commercial sectors by qualified users only.

PERI ALPHADECK is a modular slab panel formwork system which allows fast as well as safe forming operations with a systematic assembly sequence. The system provides efficient solutions for constructing slab thicknesses up to 55 cm.

The unique design of the system offers safe and confident erection from the level below.

The innovative design of ALPHADECK system ensures early striking of panel, while the props remain undisturbed.

Features

The ALPHADECK Panel frames are made of high strength and durable aluminum alloy which helps to keep the maximum panel weight below 50 kg.

The formlining used is high performance film coated birch plywood of 9 mm thickness.

Solutions for infill areas, shuttering around columns and the slab edges are also available.

For supporting the ALPHADECK panels, all PERI Props may be used subject to slab thickness and ceiling height in accordance with the "Load charts for slab props" for ALPHADECK system.

Due to early striking, the panels can be used for the new concreting cycle. Only the props with dropheads remain in position until full concrete strength has been reached. On-site material requirements are therefore clearly reduced.

Due to large sized panel, one prop can support up to 2.88 m² of slab area. This saves on both materials and working time.

In addition, the large prop spacing provides a comfortably spaced working area under the slab formwork. This facilitates the transport of formwork materials as well as the storage of construction materials.

ALPHADECK system has been designed in all respects to ensure that only a minimum of cleaning effort is required. This guarantees additional time-savings.

ALPHADECK Guardrail holder with Guardrail post HSGP-2 provides safe working conditions on the slab edges.

Technical data

System dimensions

The PERI ALPHADECK slab formwork system is designed for slab thickness up to:

- 35 cm for the panel size of 240 x 120 cm
- 55 cm for panel size of 180 x 120 cm

Evenness: Line 6 according to DIN 18202. see Section A4 - Design Information.

For permissible prop loads: see "Load charts for slab props".

Accessories dimensions

The standard ALPHADECK Filler Beams of sizes 120 / 180 / 240 cm suits the standard panels.

The ALPHADECK Bracings are of sizes 120 / 180 / 240 cm.

Cleaning and maintenance instructions



Warning

Splintering parts / concrete residue could cause injuries to the eyes and hands.

⇒ Wear safety goggles.

⇒ Wear safety gloves.

In order to maintain the value and operational readiness of the formwork materials over the long term, clean the panels after each use and ensure proper handling.

Some repair work may also be inevitable due to the tough working conditions.

The following points should help to keep cleaning and maintenance costs as low as possible.

When used continuously, spray the formwork with concrete release agent before each use e.g PERI Bio Clean; this allows easier and faster cleaning of the formwork. Spray the concrete release agent very thinly and evenly!

Immediately after striking; then clean by means of a scraper, brush or rubber lip scraper.

Important: Do not use oils (e.g. diesel, kerosene) as concrete release agent. Do not clean formlining made of plywood with high-pressure equipment; this could result in the formlining being damaged.

Fix box-outs and mounting parts with double-headed nails; as a result, the nails can easily be removed later, and damage to the formlining is largely avoided.

When placing bundles of reinforcement bars or other heavy objects on horizontally-stored formwork elements, suitable support, e.g. square timbers, is to be used; as a result, impressions and damage to the formlining are largely avoided.

Internal concrete vibrators should be fitted with rubber caps if possible; as a result, any damage to the formlining is reduced if the vibrator is accidentally “inserted” between the reinforcement and formlining.

Never clean powder-coated components, e.g. elements and accessories, with a steel brush or hard metal scraper; this ensures that the powder-coating remains intact.

Use spacers for reinforcement with large-sized supports or extensive areas of support; this largely avoids impressions being formed in the formlining when under load.

Instructions on use

The use in a way not intended according to the Instructions for Assembly and Use, or any use deviating from the standard configuration or the intended use represents a misapplication with a potential safety risk, e.g. risk of falling.

Only PERI original components may be used. The use of other products and spare parts is not allowed.

Changes to PERI components are not permitted.

Cross-system

General

The contractor must ensure that the Instructions for Assembly and Use supplied by PERI are available at all times and understood by the site personnel.

These Instructions for Assembly and Use can be used as the basis for creating a risk assessment. The risk assessment is compiled by the contractor. These Instructions for Assembly and Use do not replace the risk assessment!

Always take into consideration and comply with the safety instructions and permissible loads.

For the application and inspection of PERI products, the current safety regulations and guidelines valid in the respective countries must be observed.

Materials and working areas are to be inspected on a regular basis, especially before each use and assembly, for:

- signs of damage,
- stability and
- function.

Damaged components must be exchanged immediately on site and may no longer be used.

Safety components are to be removed only when they are no longer required.

Components provided by the contractor must conform with the characteristics required in these Instructions for Assembly and Use as well as with all valid construction guidelines and standards. Unless otherwise indicated, this applies in particular:

- Timber components: Strength Class C24 for Solid Wood according to EN 338.
- Scaffold tubes: galvanised steel tubes with minimum dimensions of $\varnothing 48.3 \times 3.2$ mm according to EN 12811-1:2003 4.2.1.2.
- Scaffold tube couplings according to EN 74.

Deviations from the standard configuration are only permitted after a further risk assessment has been carried out by the contractor. On the basis of this risk assessment, appropriate measures for working and operational safety as well as stability are to be determined.

Corresponding proof of stability can be provided by PERI on request if the risk assessment and resulting measures to be implemented are made available.

Before and after exceptional occurrences that may have an adverse effect regarding the safety of the formwork system, the contractor must immediately

- create another risk assessment, with appropriate measures for ensuring the stability of the formwork system being carried out based on the results,
- and arrange for an extraordinary inspection by a competent person. The aim of this inspection is to identify and rectify any damage in good time in order to guarantee the safe use of the formwork system.

Exceptional occurrences can include:

- accidents,
- longer periods of non-use,
- natural events, e.g. heavy rainfall, icing, heavy snowfall, storms or earthquakes.

Assembly, modification and dismantling work

Assembly, modification or dismantling of formwork systems may only be carried out by qualified persons and under the supervision of a competent person. The qualified personnel must have received appropriate training for the work to be carried out with regard to specific risks and dangers.

Erecting and dismantling of shoring requires good physical condition. Do not work on shoring if you feel dizzy, unsteady in any way or are impaired in any way by drugs or any other substance.

Deshuttering should be done once the concrete has sufficiently hardened and the person in charge has given the go-ahead for striking to take place.

On the basis of the risk assessment and Instructions for Assembly and Use, the contractor must create installation instructions in order to ensure safe assembly, modification and dismantling of the formwork system.

The contractor must ensure that the personal protective equipment required for the assembly, modification or dismantling of the system, e.g.

- safety helmet,
- safety shoes,
- safety gloves,
- safety glasses,

is available and used as intended.

If personal protective equipment against falling (PPE) is required or specified in local regulations, the contractor must determine appropriate attachment points on the basis of the risk assessment.

The personal protective equipment against falling to be used is determined by the contractor.

The contractor must

- provide safe working areas for site personnel which are to be reached through the provision of safe access ways. Areas of risk must be cordoned off and clearly marked.
- ensure the stability during all stages of construction, in particular during assembly, modification and dismantling of the formwork.
- ensure and prove that all loads can be safely transferred.

Utilization

Every contractor who uses or allows formwork systems or sections of the formwork to be used, has the responsibility for ensuring that the equipment is in good condition.

If the formwork system is used successively or at the same time by several contractors, the health and safety coordinator must point out any possible mutual hazards and all work must be then coordinated.

System-specific

Retract components only when the concrete has sufficiently hardened and the person in charge has given the go-ahead for striking to take place.

In order to avoid an overloading of the integrated temporary props, the load-bearing capacity of the slabs, plates and beams which have already been completed must be activated. For this, a free deflection possibility of these components is required. This takes place by releasing and re-installing all existing temporary props, and is also required for formwork systems where the prop head is an integral part of the slab formwork.

The load-distributing support used, such as planking, must match the respective base. If several layers are required, planks are to be arranged crosswise.

The existing prop loads (see Tables) must be safely transferred by means of sufficiently load-bearing slab props or shoring systems.

If the shuttering height is more than 3 m, then it is recommended that the shuttering be carried out using mobile scaffold.

The formwork surface area may only be accessed or loaded when the system is secured with the bracing.

The ALPHADECK bracings are to be provided for horizontal stability of the system during erection and should not be removed until deshuttering.

The stability of the total system relies upon the soffit being locked in to the permanent structure such as wall and columns.

Where the permanent works will not provide sufficient restraint to the system, additional bracing shall be introduced by tubes and fittings or ALPHADECK bracings.

Do not remove the bracing until proper authority is given.

Single post shores more than one tier high shall not be used wherever greater shore heights are required, consult the shoring supplier.

If slab props with mounted dropheads fall over or are otherwise used improperly, this may result in damage to the drophead.

As a result, dropheads could fail during further use and cause serious injuries to site personnel.

- Dismantle dropheads after incorrect use and check for any signs of damage, e.g. cracked flyplate or wedge.
- Damaged components must not be used!

The horizontal fixed position of the slab formwork must be guaranteed. The transfer of the horizontal loads has to be guaranteed by means of other measures supplied by the contractor, e.g. anchor chains or bracing.

Load assumptions for horizontal loads in accordance with DIN EN 12812.

Anchoring is to take place only if the anchorage has sufficient concrete strength.

When storing heavy items on the formwork, the load-bearing capacity must be taken into consideration.

Cantilevers may only be accessed after the panels are securely anchored using anchor chains.

When wind speeds reach 28 km/h and more, panels can lift off and the slab formwork can collapse.

Falling components can strike personnel and seriously injure them.

To avoid such an incident:

- Apply ballast to the slab formwork.
- Dismantling the formwork for unfavourable structure geometries.

Storage and transportation

Store and transport components ensures that no unintentional change in their position is possible. Detach lifting accessories and slings from the lowered components only if they are in a stable position and no unintentional change is possible.

Do not drop the components.

Use PERI lifting accessories and slings as well as only those load-bearing points provided on the component.

During the moving procedure

- ensure that components are picked up and set down so that unintentional falling over, falling apart, sliding, falling down or rolling is avoided.
- no persons are allowed to remain under the suspended load.

Always guide pre-assembled scaffolding bays, scaffolding units or scaffolding sections with ropes when moving them by crane.

Dismantled components should be stacked in a planned manner and distributed to avoid concentrated loads on the partially cured concrete.

The access areas on the construction site must be free of obstacles and tripping hazards as well as being slip-resistant.

For transportation, the surface must have sufficient load-bearing capacity.

Use original PERI storage and transport systems, e.g. crate pallets, pallets or stacking devices.

A1 Component Overview

| Position number in illustrations | Component name |
|----------------------------------|---|
| 1 | Panel ADP |
| 2 | Drophead ADH |
| 3 | Prop |
| 4 | Pallet AD |
| 5 | Crate pallet 80 x 120 |
| 6 | Shuttering aid AD |
| 7 | Bracing ADB |
| 8 | Filler beam ADF |
| 9 | Guardrail holder ADG |
| 10 | Guardrail post HSGP-2 |
| 11 | Plywood |
| 12 | Additional prop with crosshead and Girder VT 20 |
| 13 | Cross beam head |
| 14 | Timber (50 x 100 mm) |
| 15 | Guardrail boards |
| 16 | Crosshead ADC |
| 17 | Anchor chain 3.0 kN |
| 18 | Turn buckle 3.0 kN |
| 19 | Base plate RS |
| 20 | Pin and cotter pin |
| 21 | Anchor bolt PERI 14/20 x 130 |
| 22 | Z-bracings |
| 23 | Timber block |



- Instructions for Use for PERI Pallets and Stacking Devices must always be taken into consideration.
- Manually-created transport units must be correctly stacked and secured.
- Pallets and stacked components are to be protected against the effects of the weather, e.g. secure packed components against lifting using tension straps.
- Always attach crane slings to all load-bearing points.

Transportation

PERI ALPHADECK pallets (4) are suitable for lifting by crane or forklift. The pallets can also be attached with castor wheels (art. no.: 111690) and therefore can be moved manually in horizontal direction. The castor wheels can be removed or installed using four nos. each of M10 x 30 bolt (art. no.: 116436) and M10 nut (art. no.: 710234). See detail A (4.1).

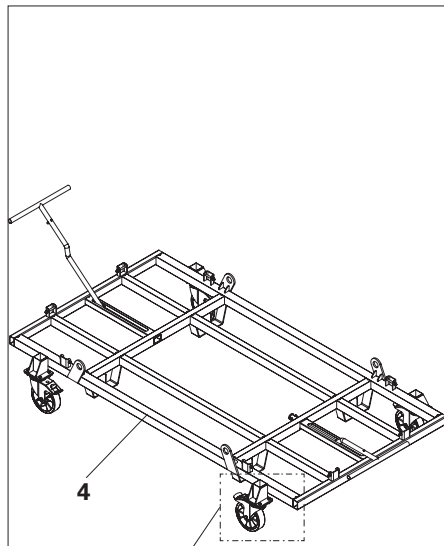
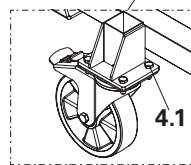

Fig. A2.01



Detail A

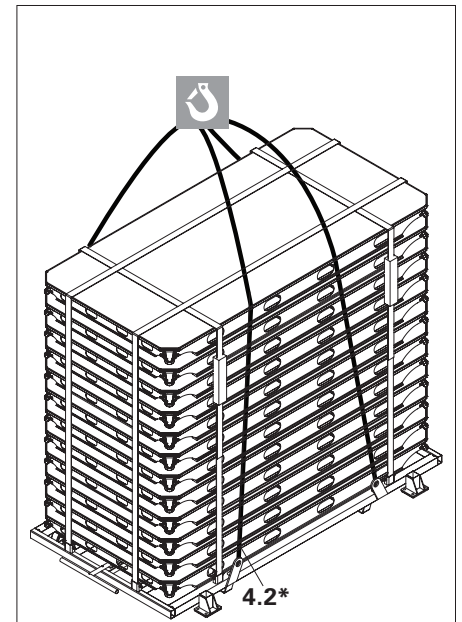

Fig. A2.02



- Lashing straps are manufactured according to DIN EN 12195-2, and are to be regularly checked in accordance with this standard.
- Use crane slings (4.2*) to position the long panel sides at the side of the pallet.
- Use all 4 attachment points for crane slings (4.2*) when transporting by crane.
- Do not mix the stacks. Always ensure that the stacks are of equal height on each transport pallet.

Pallet AD

The panels are stacked one above the other. Always turn the formlining side upwards so that water can drain off. The maximum height of single pallet stack should not exceed 2.2 m.

Pallet AD 240: 12 pieces (ADP 240)
Total weight (single stack): 680 kg

Pallet AD 180: 12 pieces (ADP 180)
Total weight (single stack): 550 kg
(above mentioned weights of single stack are including pallet)

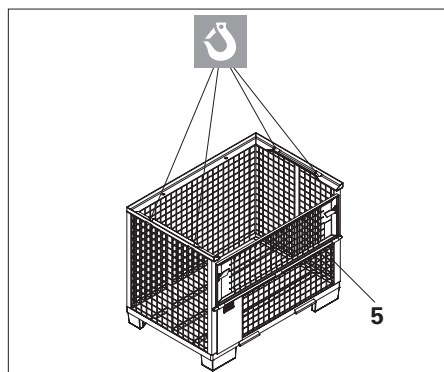

Fig. A2.03

* In contractor's scope - load capacity to be checked.

Stacking:

2 loaded pallets, one on top of the other.

Crate Pallet 80 x 120

Load-bearing capacity = 1.5 t
Crane sling angle $\leq 15^\circ$
Stacking height: 3 crate pallets on top of each other
For better loading and unloading, the flap (5.1) can be pivoted downwards.
For securing the load against theft, the crate pallet (5) can be optionally fitted with a cover (art. no.: 065067).

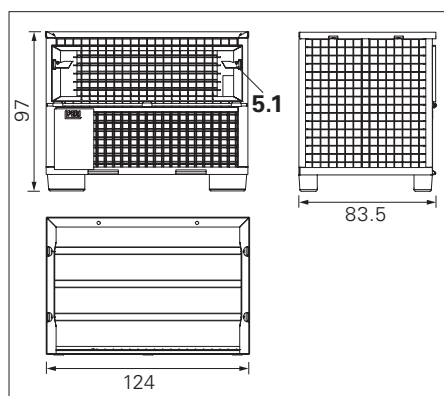

Fig. A2.04



Before transportation, close the flap and check that locking mechanism have properly engaged.

Panel ADP

The Panel ADP is available in two sizes:

- Panel ADP 240 x 120
- Panel ADP 180 x 120

The Panel ADP frames are made of high strength and durable aluminum alloy which helps to keep the maximum panel weight below 50kg.

ALPHADECK panels are powder-coated. The panels have minimal contact area and undercut edges. (Fig. A3.03) This minimizes the accumulation of slurry on the sides of the panels.

The formlining used is high performance film coated birch plywood of 9 mm thickness.



Fig. A3.01

Components:

- 1** Panel ADP
- 1.1** Formlining
- 1.2** Panel frame
- 1.3** Edge rail A
- 1.4** Edge rail B
- 1.5** Cross strut C
- 1.6** Stiffener
- 1.7** Corner element
- 1.8** Connecting hole for guardrail holder ADG
- 1.9** Connecting hole for anchor chain 3.0 kN

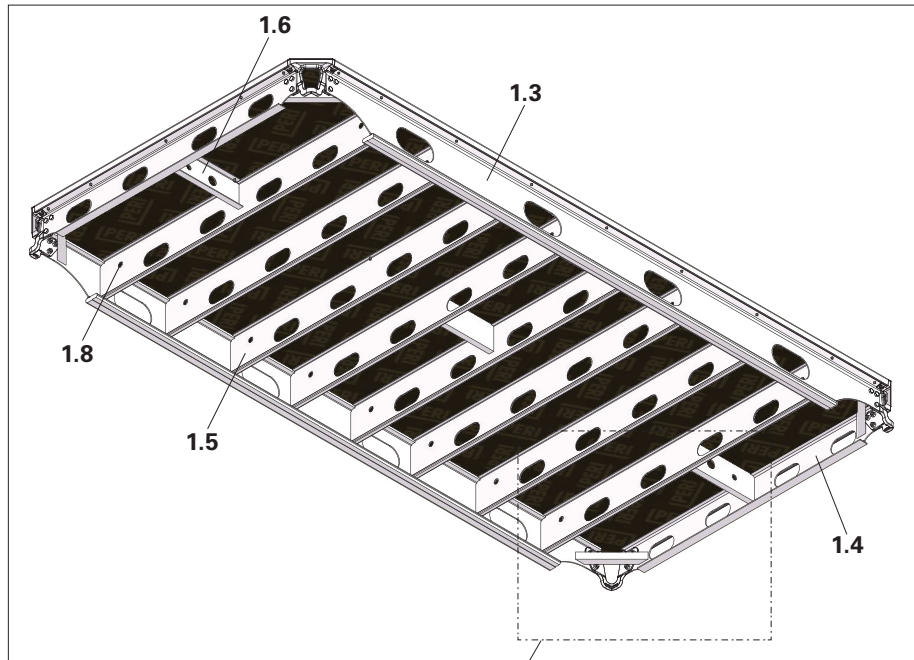

Fig. A3.02

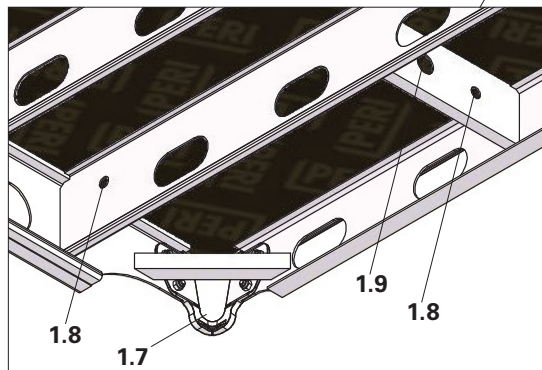

Fig. A3.02a

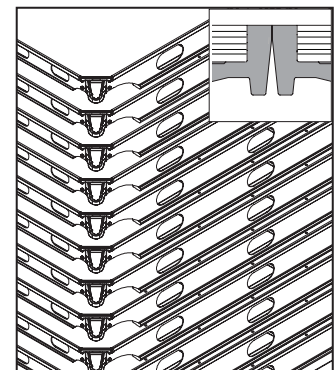

Fig. A3.03

Drophead ADH

The drophead ADH allows early striking and easier deshuttering of panels. Only one type of head serves all requirements. The drophead is released with the help of a hammer, which causes the panel to drop by 12 cm.

Components:

- 2** Drophead ADH
- 2.1** Vertical stem
- 2.1a** Top plate
- 2.1b** Tube
- 2.1c** Loading pin
- 2.1d** Stopper
- 2.1e** Bottom plate
- 2.2** Flyplate
- 2.3** Wedge
- 2.3a** Nose
- 2.4** M12 bolt, nut and washer

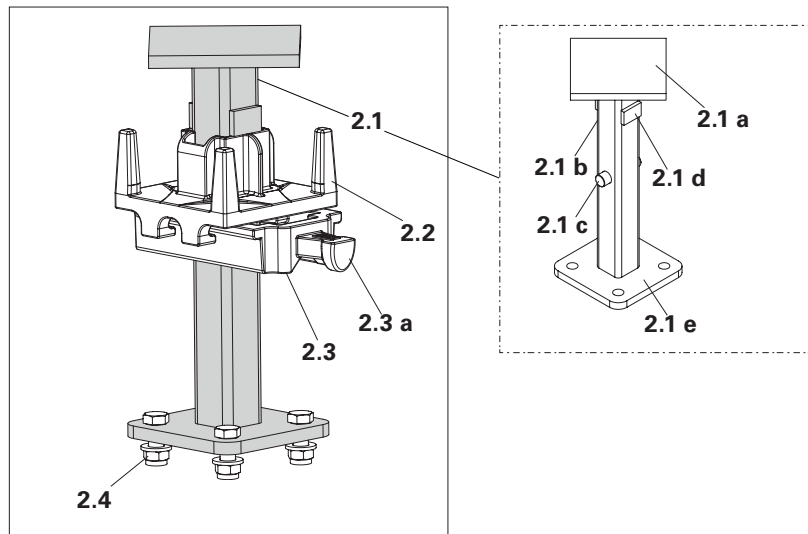

Fig. A3.04

Shuttering Aid AD

The shuttering aid AD (6) is used to assemble and dismantle the Panel ADP. The length is adjustable from 2.5 m to 4.3 m with 10 cm intervals.



Warning

The shuttering aid can slip sideways, e.g. through an impact, and thus cause the component being held to collapse.
 ⇒ Always ensure that the shuttering aid is secured by a member of the construction team.



- Length adjustments are to be carried out only in an unloaded state.
- Always insert the linch pin (6.1) through both holes of the inner (6.3) and outer (6.2) tubes.
- The inner tube (6.3) should not be resting on top of the linch pin (6.1).
- Secure the linch pin (6.1). (Fig. A3.05a)

Components:

- 6** Shuttering aid AD
- 6.1** Linch pin
- 6.2** Outer tube
- 6.3** Inner tube
- 6.4** Head
- 6.5** M10 x 50 bolt and nut

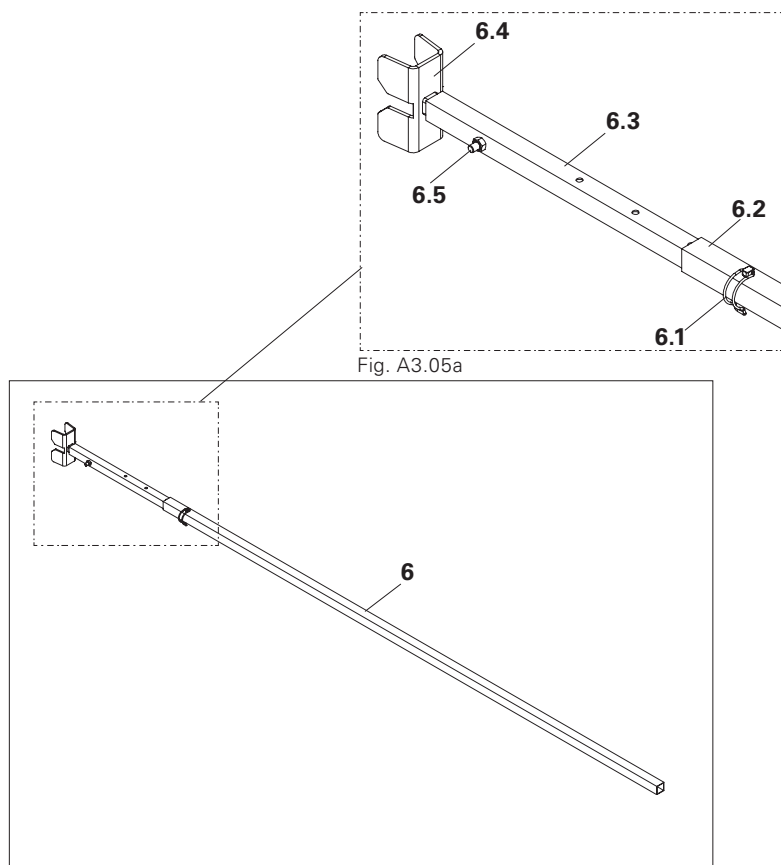

Fig. A3.05

Slab Props

PERI PEP ERGO, PEP Alpha and PEP Alpha-2 are recommended for slab formwork with ALPHADECK system.



- Take into account the permissible prop loads of the slab props, see “Load charts for slab props”.
- Maximum permissible slab thickness is 35 cm for the Panel ADP 240 x 120 and 55 cm for the Panel ADP 180 x 120.

Preparation of the slab props

1. The exact extension length of the prop when using the ALPHADECK drophead is:
Prop height = Clear room height minus 31.5 cm
2. Please use suitable prop so that the permissible prop load is more than actual prop loads.
3. Use M12 bolt (2.4 a), nut (2.4 b) and washer (2.4 c) to attach the prop (3) to the drophead (2). (Fig. A3.06)

Components:

- 2** Drophead ADH
- 2.4a** M12 bolt
- 2.4b** Nut
- 2.4c** Washer
- 3** Prop

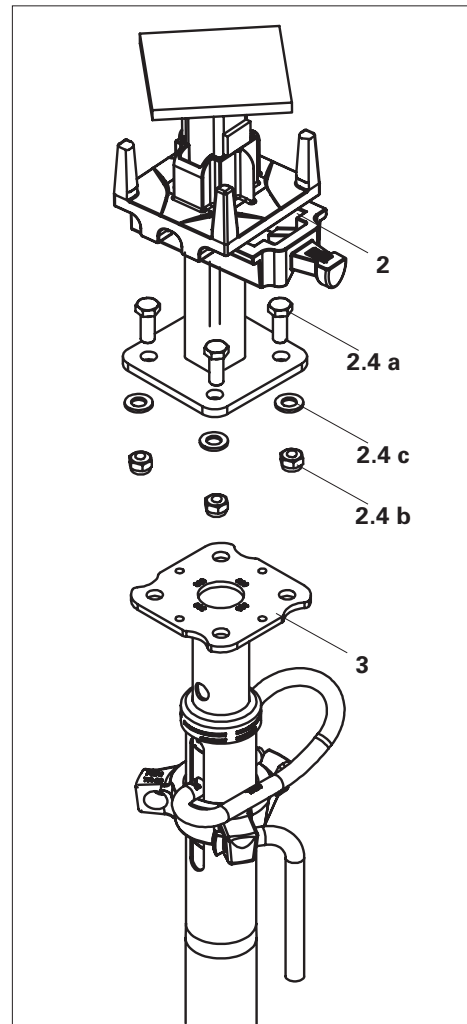

Fig. A3.06



Always use M12 bolt on the drophead (2) side and nut on the prop (3) side. (Fig. A3.06a)

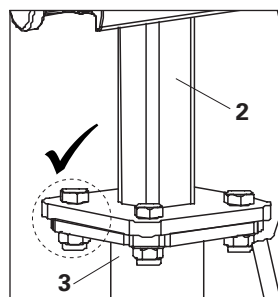

Fig. A3.06a

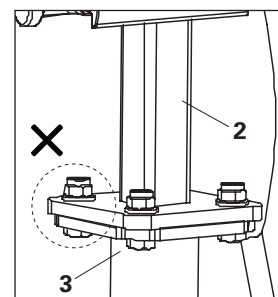

Fig. A3.06b



Warning

Risk of collapse!
A fall can result in serious injuries or even death!

- ⇒ Always use four M12 bolts (2.4 a), four nuts (2.4 b) and four washers (2.4 c) while fixing drophead to the prop. (Fig. A3.06c)

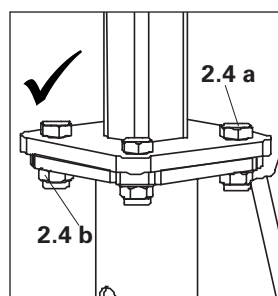

Fig. A3.06c

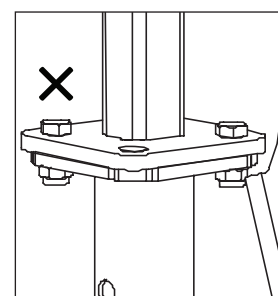

Fig. A3.06d

Bracing ADB

Bracing ADB provides temporary stability for the ALPHADECK system during its erection.

Bracing ADB are available in three sizes: ADB 240, ADB 180 and ADB 120

Components:

- 7** Bracing ADB
- 7.1** PRK head
- 7.2** Bracing frame
- 7.3** M12 x 70 Bolt and nut

Bracing ADB can be used with prop of outer diameter above 57 mm. If props are below 57 mm diameter, then timber with brace clamps can be used for bracing. (Fig. A3.07a) Mount diagonal bracing as assembly aid with boards and brace clamps.

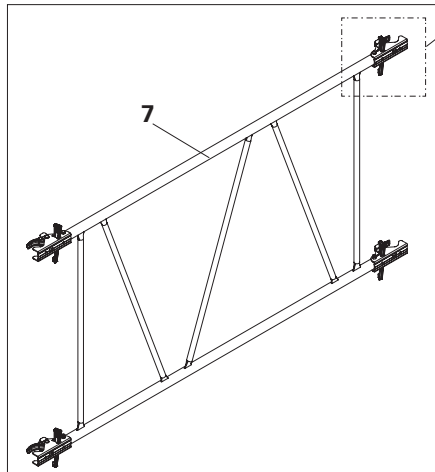

Fig. A3.07

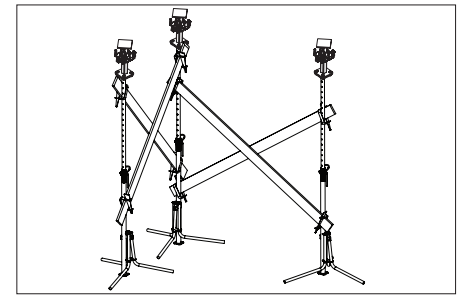
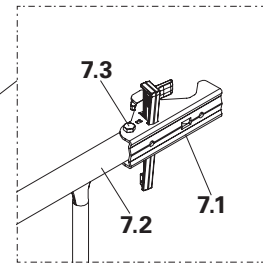

Fig. A3.07a

Filler beam ADF

Infill areas can be closed with the Filler beam ADF (8) and cut to suit plywood.

Filler beam ADF are available in three sizes: ADF 240, ADF 180 and ADF 120.

The same filler beam is compatible for plywood thickness (t) ranging from 12 mm to 18 mm by varying the timber insert (8.3) size. (Fig. A3.08a)

- d = depth of timber insert
- t = plywood thickness
- w = width of timber insert

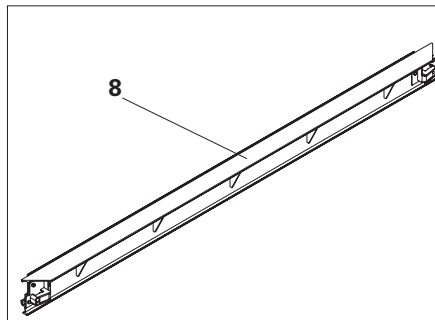

Fig. A3.08

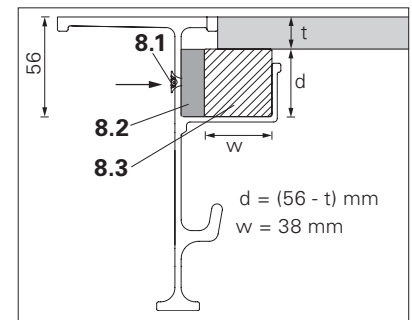

Fig. A3.08a

Use torx screw 6 x 40 mm (8.1) article no. 024540 to secure the timber insert (8.3) with 12 mm packing (8.2) at every 60 cm c/c. Fig. A3.08a

Guardrail holder ADG with Guardrail post HSGP-2

The ALPHADECK Guardrail holder with Guardrail post HSGP-2 secures site personnel working on a casting segment against falling in both directions. (Fig. A3.09)

The system consists of Guardrail holder (9) and Guardrail post HSGP-2 (10)

Components:

- 9** Guardrail holder ADG
- 10** Guardrail post HSGP-2

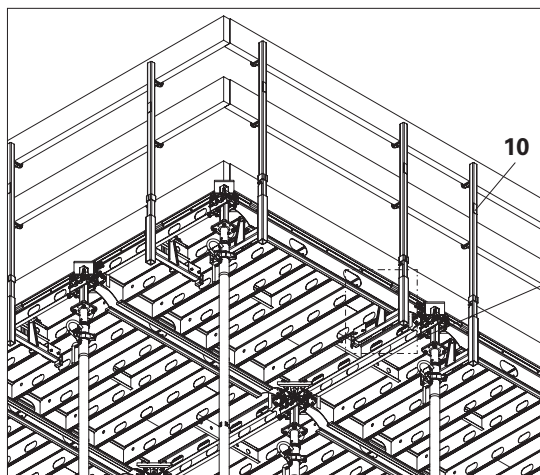
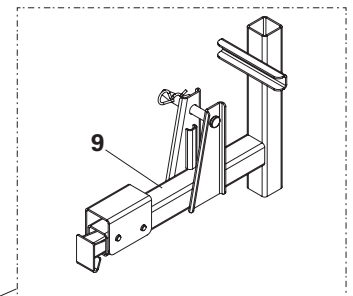

Fig. A3.09



Notes for static calculations

This design information is used for the design and planning of the ALPHADECK Slab Formwork System. It covers standard configurations for slab thickness of 35 cm for the Panel ADP 240 x 120 and 55 cm for Panel ADP 180 x 120.

Comparison of the design methods

The design concept with partial safety factors

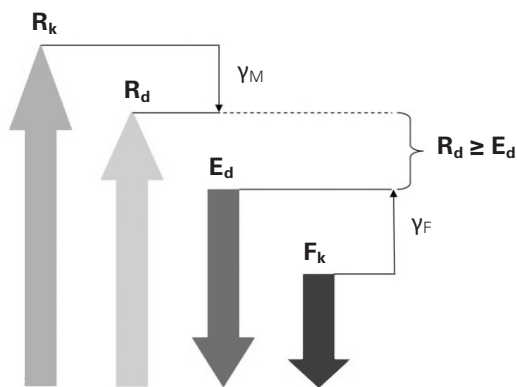

Method of proof

$$\frac{R_k}{\gamma_M} \geq F_k \cdot \gamma_F$$

$$\underbrace{\quad}_{R_d} \geq \underbrace{\quad}_{E_d}$$

The old design concept with the absolute safety factor (see PERI Design Tables)

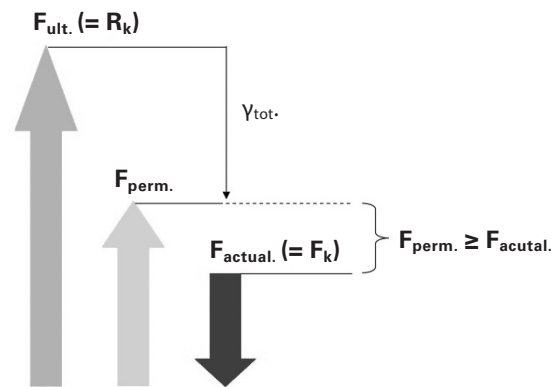

Method of proof

$$\frac{F_{ult.}}{\gamma_{tot.}} \geq F_{actual.} (= F_k)$$

$$\underbrace{\quad}_{F_{perm.}} \geq \underbrace{\quad}_{F_{actual.} (= F_k)}$$

Key

- R_k = characteristic resistance
- R_d = design value of the resistance
- $F_k = F_{actual.}$ = actual or characteristic action
- E_d = design value of the action
- $F_{ult.} = R_k$ = characteristic resistance (e.g. breaking load)
- $F_{perm.}$ = Permissible load-bearing capacity

- γ_M = partial safety factor for the material (steel ≈ 1.1 / concrete ≈ 1.5)
- γ_F = partial safety factor for the load (permanent = 1.35 / changeable = 1.5)
- $\gamma_{tot.}$ = absolute safety factor $\approx \gamma_M \cdot \gamma_F$ (steel ≈ 1.65 / concrete ≈ 2.25)

Design method used in this design information

This design information is based on the design concept with the absolute safety factor.

The tables of the prop loads include the permissible load-bearing capacities

$F_{perm.}$

After multiplication using $\gamma_F = 1.5$, the maximum load-bearing capacity can also be converted into a design value of the resistance R_d for the method with partial safety factors.

Prop loads in panel system

| Slab thickness d [mm] | Total Load q** [kN/m ²] | Prop load [kN] | Deflection to DIN 18202, Line | Prop load [kN] | | Deflection to DIN 18202, Line | |
|--------------------------|--|-------------------|-------------------------------------|---------------------|---------------------|----------------------------------|---------------------|
| | | | | Panel ADP 240 x 120 | Panel ADP 180 x 120 | Panel ADP 240 x 120 | Panel ADP 180 x 120 |
| 100 | 4.2 | 12.1 | 7 | 9.1 | 7 | 7 | 7 |
| 125 | 4.9 | 14.2 | 7 | 10.6 | 7 | 7 | 7 |
| 150 | 5.5 | 15.9 | 7 | 11.9 | 7 | 7 | 7 |
| 175 | 6.1 | 17.6 | 7 | 13.2 | 7 | 7 | 7 |
| 200 | 6.7 | 19.3 | 7 | 14.5 | 7 | 7 | 7 |
| 225 | 7.4 | 21.4 | 7 | 16.0 | 7 | 7 | 7 |
| 250 | 8.0 | 23.1 | 6 | 17.3 | 7 | 7 | 7 |
| 275 | 8.6 | 24.8 | 6 | 18.6 | 7 | 7 | 7 |
| 300 | 9.2 | 26.5 | 6 | 19.9 | 7 | 7 | 7 |
| 325 | 9.9 | 28.6 | 6 | 21.4 | 7 | 7 | 7 |
| 350 | 10.6 | 30.6 | 6 | 22.9 | 7 | 7 | 7 |
| 375 | 11.3 | - | - | 24.5 | 7 | 7 | 7 |
| 400 | 12.0 | - | - | 26.0 | 7 | 7 | 7 |
| 425 | 12.7 | - | - | 27.5 | 7 | 7 | 7 |
| 450 | 13.4 | - | - | 29.0 | 6 | 6 | 6 |
| 475 | 14.1 | - | - | 30.5 | 6 | 6 | 6 |
| 500 | 14.7 | - | - | 31.8 | 6 | 6 | 6 |
| 525 | 15.4 | - | - | 33.3 | 6 | 6 | 6 |
| 550 | 16.1 | - | - | 34.8 | 6 | 6 | 6 |

Table. A4.01

Calculation basis:

**Load according to EN 12812

$$\begin{aligned}
 \text{Dead load } Q_1 &= 0.20 \text{ kN/m}^2 \\
 \text{Concrete load } Q_{2,b} &= 25 \text{ kN/m}^3 \times d \text{ [m]} \\
 \text{Equivalent load concreting } Q_4 &= 0.10 \times Q_{2,b} \\
 &= 0.75 \text{ kN/m}^2 \leq Q_4 \leq 1.75 \text{ kN/m}^2 \\
 \text{Equivalent load working conditions } Q_{2,p} &= 0.75 \text{ kN/m}^2 \\
 \text{Total load } Q &= Q_1 + Q_{2,b} + Q_{2,p} + Q_4
 \end{aligned}$$

Note:

- Please use suitable prop so that the actual prop load given in Table A4.01 is less than the permissible prop loads shown in Section "Load charts for slab props".
- When calculating the perm. prop loads, the extension length of the prop should be considered up to top of the flyplate**
Extension length = clear room height - 12 cm.
 → **For actual prop length required for slab preparation, refer to page 12.**
- When using the Anchor chain 3.0 kN, increase the prop loads for the braced panels considering 2.6 kN per chain.
- If Anchor chain 3.0 kN is used in the system, consider deflection according to DIN 18202 Line 6 for all slab thickness.
- Deflection is according to DIN 18202 assuming perfect levelling.

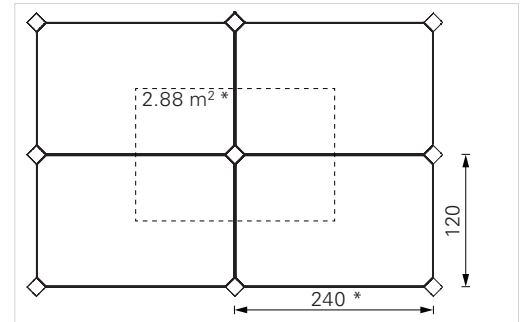

Fig. A4.01

*For ADP 180, influence area of prop = 2.16 m²

Example for calculation of perm. prop load

| | |
|---|--|
| Floor to floor height | = 4.0 m |
| Slab thickness | = 25 cm |
| Clear room height (4.00 m - 0.25 m) | = 3.75 m |
| Extension length (clear room height - 12 cm) | = 3.63 m ~ 3.7 m |
| | = 3.75 m - 0.12 m |
| Max. panel size | = ADP 240 x 120 |
| Actual prop load (Refer to Table A4.01) | = 23.1 kN |
| Selected prop | = PEP Ergo D400 |
| Direction of assembly | Inner bottom <input type="checkbox"/> |
| | Outer bottom <input checked="" type="checkbox"/> |
| Perm. prop load (according to PERI Tables - refer to Table A4.02) | = 27 kN |
| Actual prop load ≤ Perm. prop load | OK <input checked="" type="checkbox"/> Not OK <input type="checkbox"/> |
| Hence, SAFE | |

Extract of load chart for slab prop

| Extension length [m] | PEP Ergo D-400 | |
|----------------------|-------------------|-------------------|
| | Outer tube bottom | Inner tube bottom |
| 3.50 | 31.0 | 39.7 |
| 3.60 | 29.0 | 36.4 |
| 3.70 | 27.0 | 33.3 |
| 3.80 | 25.2 | 30.7 |
| 3.90 | 23.5 | 28.2 |

Table. A4.02

General

Warning

- During assembly, components could fall out, strike personnel and seriously injure them as a result of carelessness or maloperation!
 - ⇒ Do not remain in the areas of risk for no good reason.
 - ⇒ Wear a safety helmet.
 - ⇒ Wear safety shoes.
 - ⇒ Wear safety gloves.
- When wind speeds reach 28 km/h and more, panels can lift off and the slab formwork can collapse! Falling components can strike personnel and seriously injure them. To avoid such an incident:
 - ⇒ Apply ballast to the slab formwork.
 - ⇒ Dismantle the formwork for unfavourable structure geometries.



- For working areas with shuttering height 3 m and above, choose a safe working area, e.g. mobile scaffolds.
- Shuttering from above wherever required to be done is permitted only with PPE.



- Plan slab formwork carefully. When planning the layout, take building columns, projections and recesses and other filler areas into account.
- It is not mandatory to start the system from wall corner. The system can be erected using bracings from anywhere in between. But if required, start at a corner of the room as per the layout.
- Position the slab props in such a way that it is possible to handle the G hooks and keep them secured.
- Allow for a striking clearance of 2.5 cm at the props.

Starting bay

1. Extend props (3) to required working height. Refer to Preparation of slab props on page 12.
2. Erect three props at the starting corner (L-shaped). (Fig. A5.01)



To facilitate easy striking, ensure that the direction of wedge (2.3) is parallel to the width of the panel with its nose facing inwards i.e. opposite to the direction of assembly. Detail A.

3. Attach the bracing ADB (7) to the props (3).
4. To lock the bracing ADB (7), strike the wedge (7.1) by hammer. Detail B. Make sure that the wedge is properly locked to the props to ensure stability.



When installing bracing ADB (7), ensure that the bottom wedge of PRK head (7.1) has enough clearance of 30 cm from the ground for easy removal. Detail B.

5. Hang the panel ADP (1) into the two props. (Fig. A5.02)



Make sure that the panel corners are properly hooked onto the drophead ADH (2) flyplate pin. Detail C.

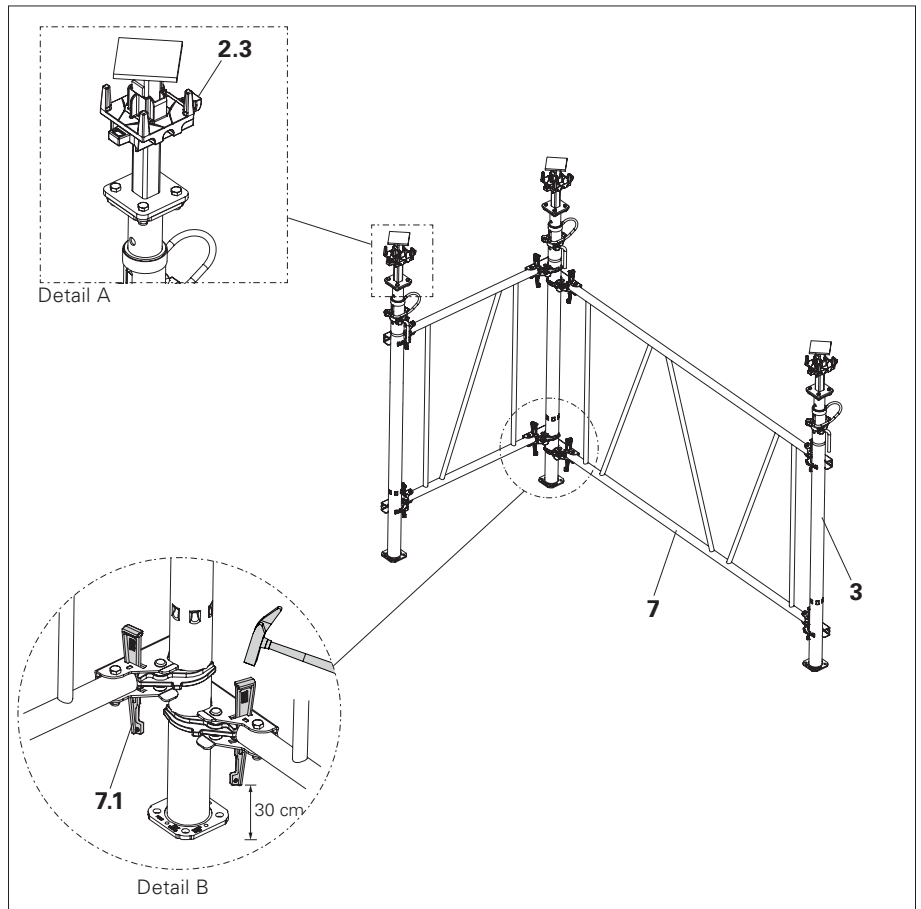

Fig. A5.01

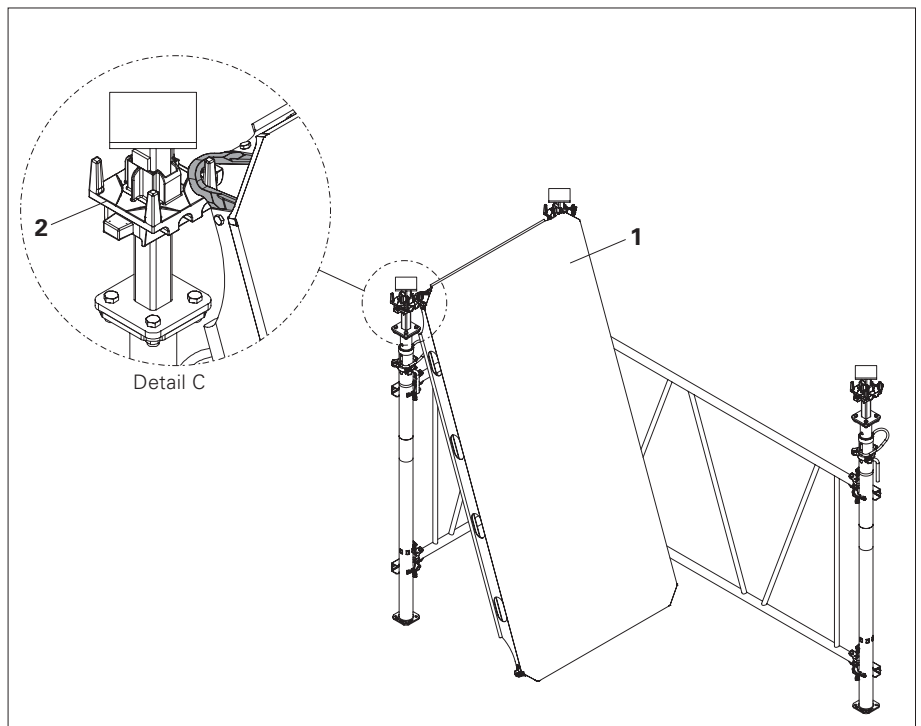

Fig. A5.02

6. Swing the panel ADP (1) upwards with the shuttering aid (6) and hook on the third prop (3). (Fig. A5.03).



Ensure that the shuttering aid is supporting the panel edge in the middle to avoid tilting. Detail D.

7. Secure with shuttering aid temporarily until the prop is brought into support position. Detail E.

8. While the shuttering aid is supporting, attach the fourth prop to the panel corner. (Fig. A5.04)

9. Install bracing ADB 120 to the fourth prop. (Fig. A5.05)
→ The starting bay is complete.

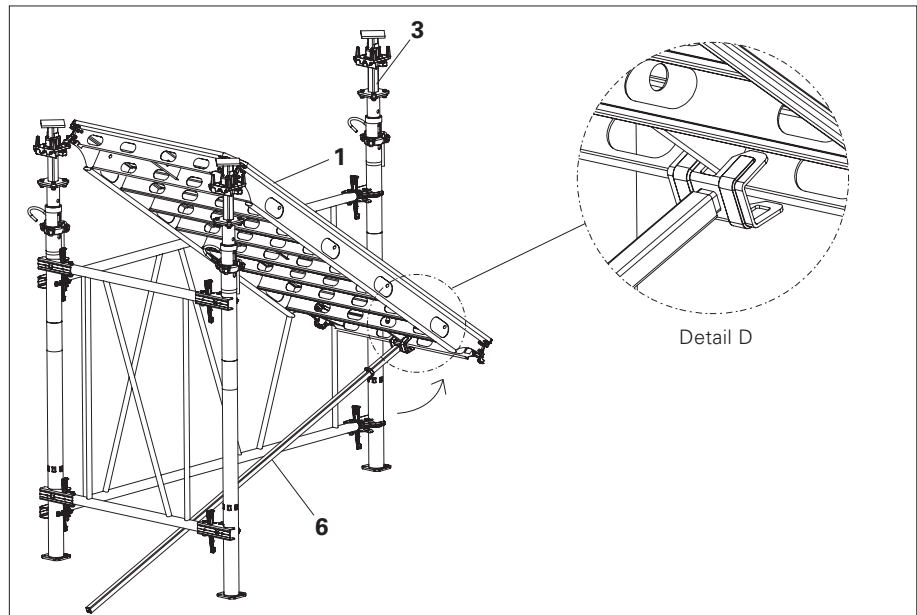

Fig. A5.03

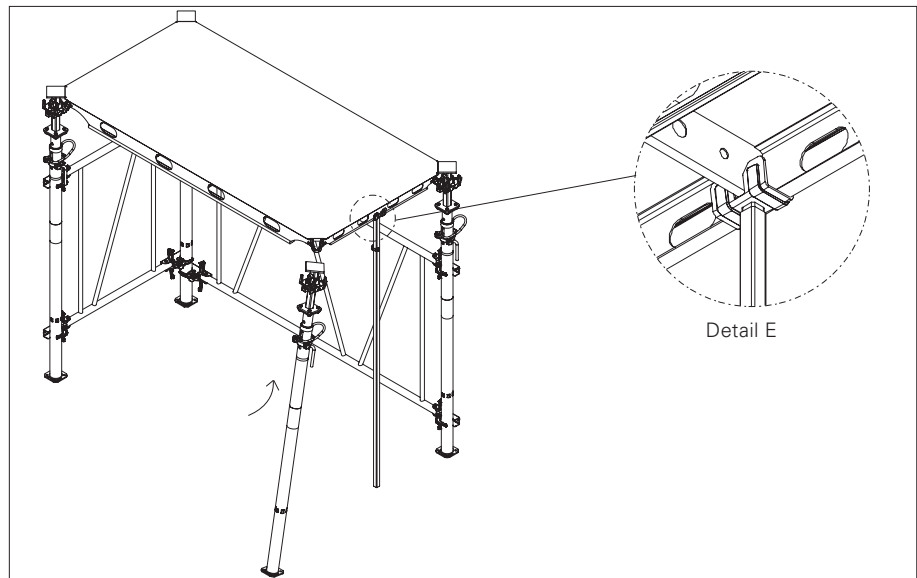

Fig. A5.04

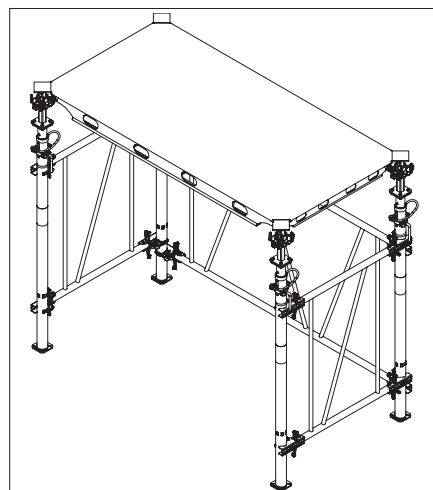

Fig. A5.05

Shorter direction

1. To continue erection in shorter direction, assemble the adjacent panel in the same way.
2. Using the shuttering aid, swing the panel up supporting it temporarily until the next two props are installed. (Fig. A5.07)



Ensure that the shuttering aid is supporting the panel edge in the middle to avoid tilting.

3. Attach the next two props to the panel corners in the same manner. (Fig. A5.08).



Ensure that the direction of wedge is parallel to the width of the panel with its nose facing inwards. Detail F.

4. Repeat the process until the first row of the panels have been erected in shorter direction.

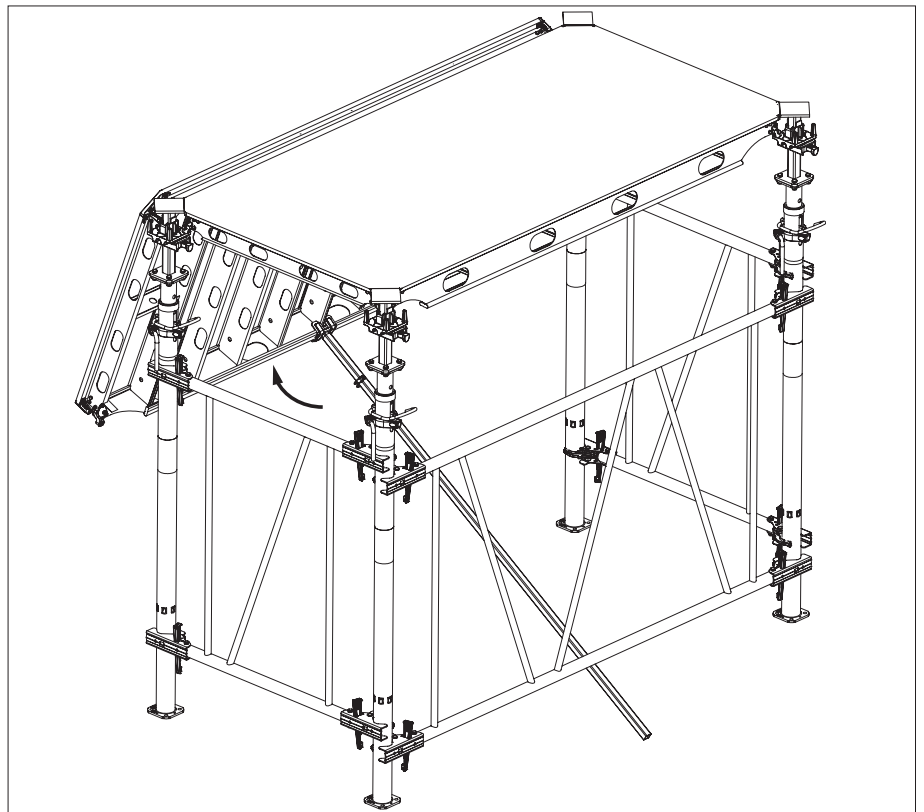

Fig. A5.07

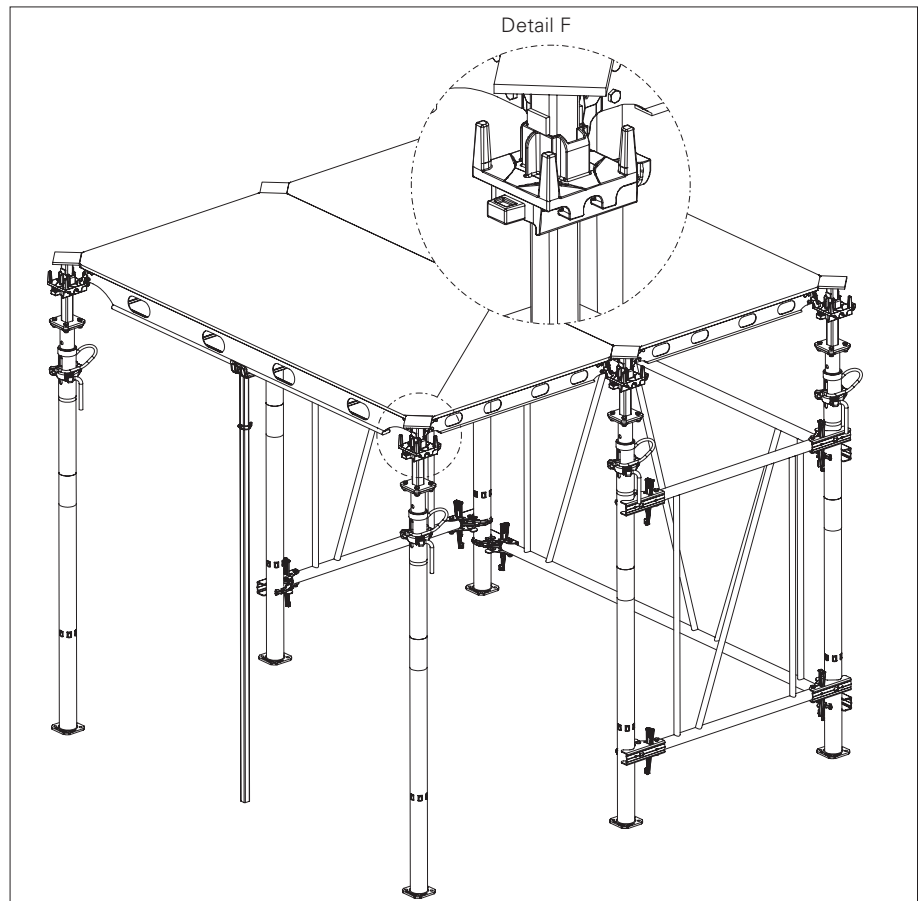

Fig. A5.08

The assembly can be continued simultaneously in any direction.

Longer direction

1. Hang the next panel into the props as done in shorter direction.
2. Using the shuttering aid, swing the panel up supporting it temporarily until the next two props are installed. (Fig. A5.09)
3. While keeping the shuttering aid as a temporary support, attach the next prop to the third corner of the panel. (Fig. A5.10)
4. Hook and swing the next panel (as shown in step 1 & 2) using an additional shuttering aid. (Fig. A5.11)

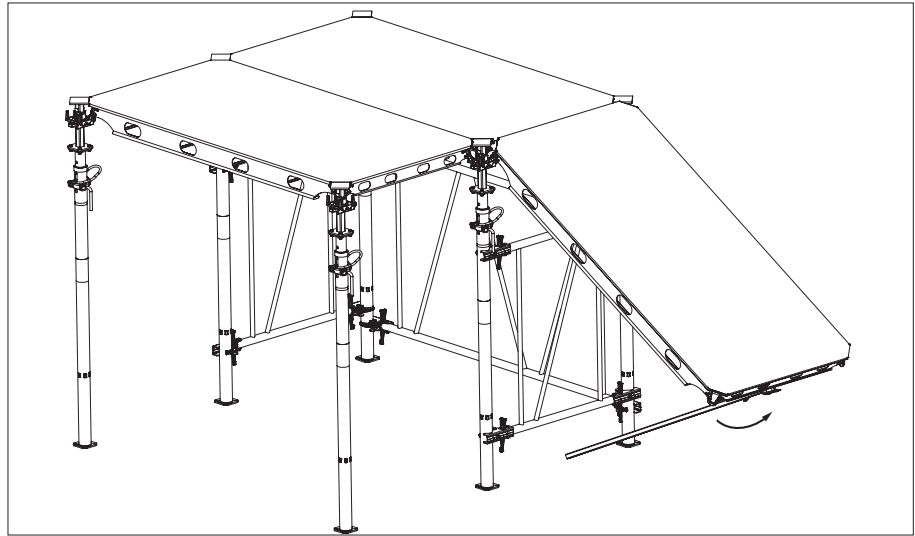

Fig. A5.09

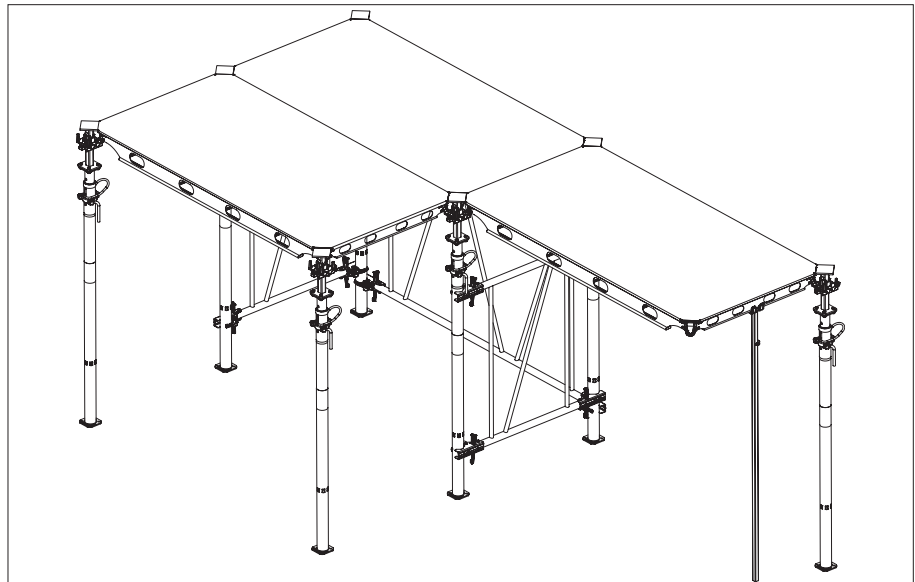

Fig. A5.10

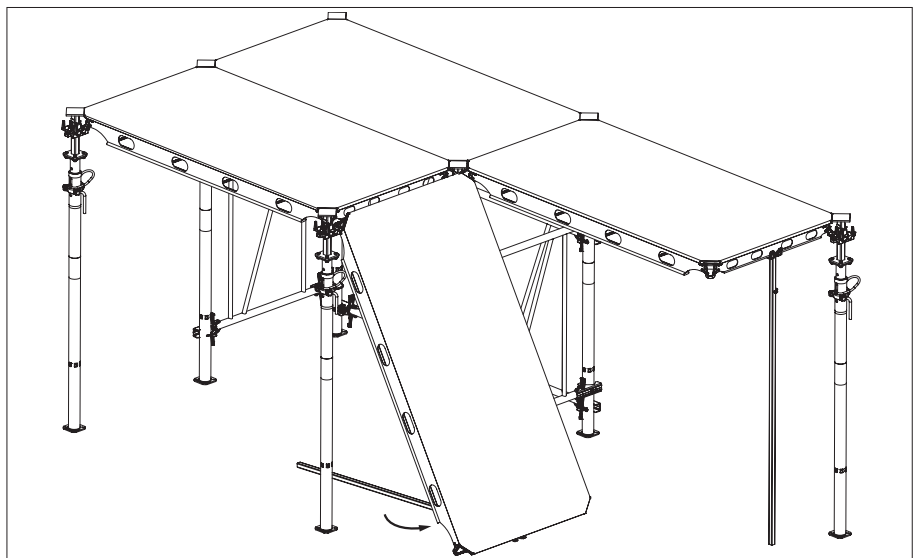

Fig. A5.11

5. Now, both the shuttering aids act as temporary support until the next prop is attached to the panel corner. (Fig. A5.12)



Ensure that the shuttering aid is supporting the panel edge in the middle to avoid tilting.

6. Insert the prop into position with the wedge oriented in shorter direction for easy deshuttering. (Fig. A5.13)

7. Once the prop is set into position, the first shuttering aid can be removed while the second shuttering aid supports the panel further. (Fig. A5.14)

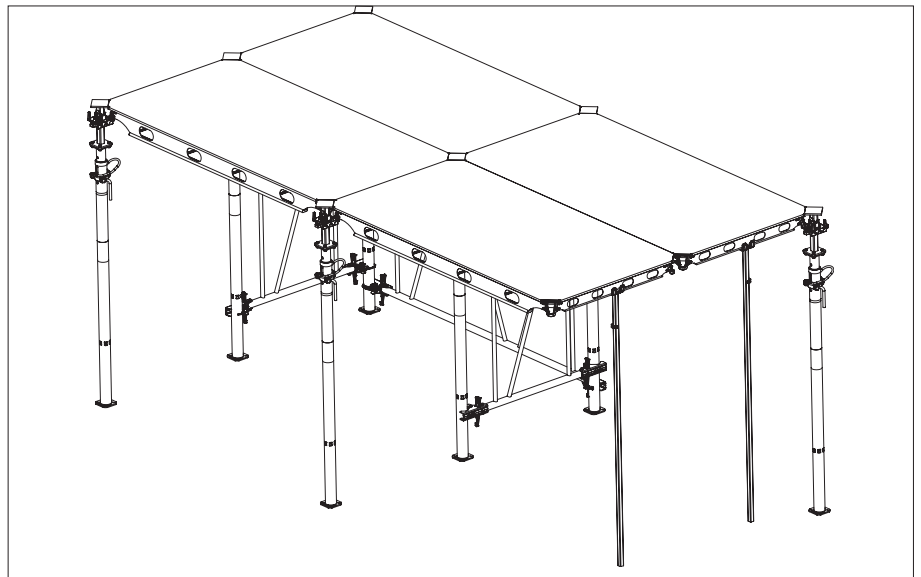

Fig. A5.12

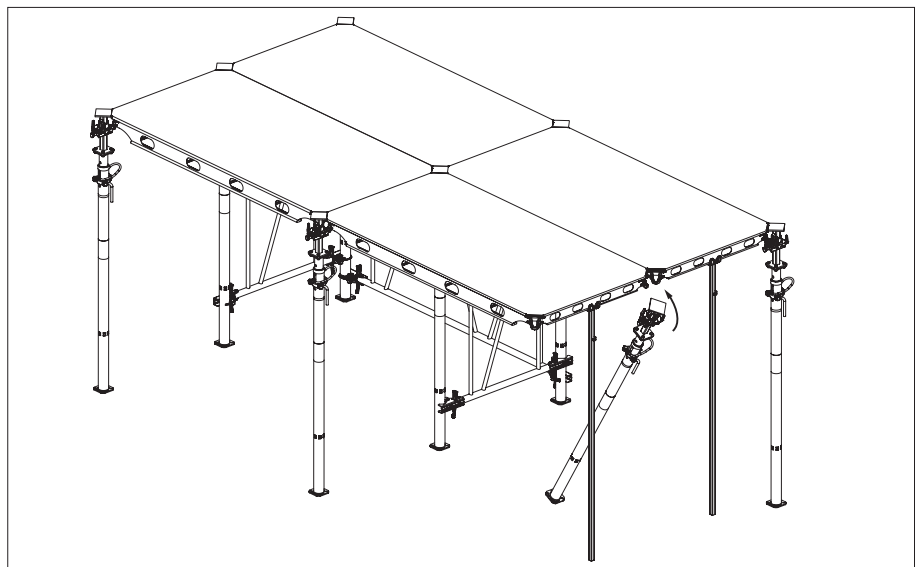

Fig. A5.13

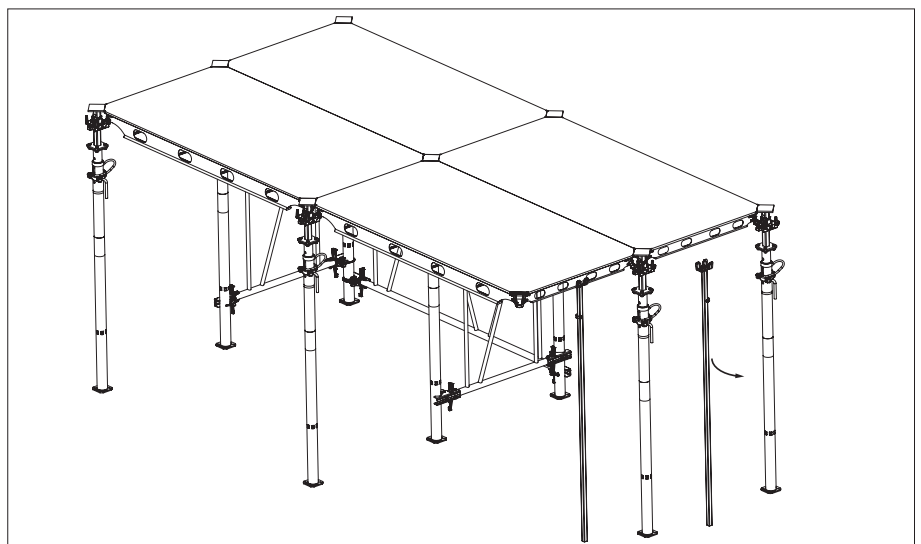

Fig. A5.14

8. Repeat the process until the shuttering is completed in both the directions.
9. Once the last prop is set into position, remove the second shuttering aid (Fig. A5.15)

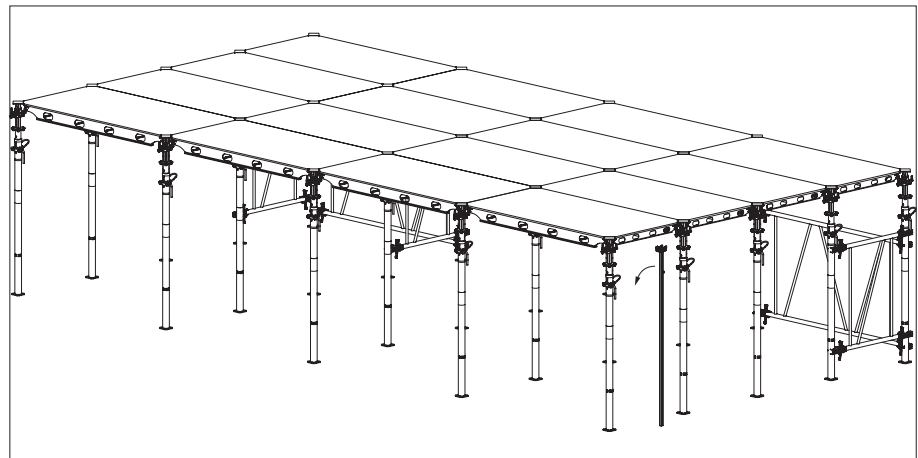

Fig. A5.15

Bracing ADB Guidelines



Warning

Risk of collapse!

A fall can result in serious injuries or even death!

⇒ Bracings must be provided after every third bay in longer direction and every sixth bay in shorter direction. i.e. maximum of 7.2 m spacing between bracings in any direction. (Fig. A5.16)

⇒ Make sure that all drophead ADH wedges are properly tightened before commencement of concreting.

During erection, the ALPHADECK system is stabilized using Bracing ADB as per the requirement.

During all subsequent stages, the system requires adequate overall fixity at the soffit. This means that the system is not free standing when loaded.

The stability of the total system relies upon the soffit infill plywood being locked in to the permanent structure such as around column heads or walls.

It is the contractor's responsibility to ensure that the permanent works and the interface with the soffit, as constructed on site, can resist and safely transfer all notional and actual horizontal loads to prevent any collapse.

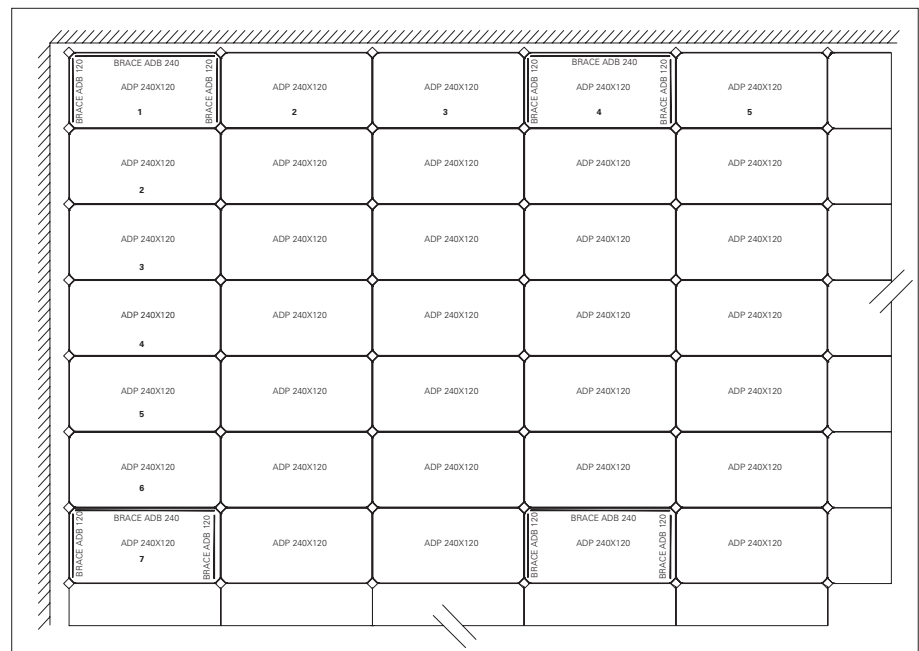

Fig. A5.16

Company:

Project:

Checks to be carried out on the construction site before concreting

1. Structure info table

| | | | |
|--|--------------------------|--------------------------|---------------------------------|
| Floor to floor height | = | | m |
| Slab thickness | = | | cm |
| Clear room height | = | | m |
| Extension length for prop load calculation (clear room height - 12 cm) | = | | m |
| Max. panel size | = | | cm |
| Actual prop load (according to Table A4.01) | = | | kN |
| Selected prop | = | | |
| Direction of assembly | Inner bottom | <input type="checkbox"/> | |
| | Outer bottom | <input type="checkbox"/> | |
| Perm. prop load (according to PERI Tables) | = | | kN |
| Actual prop load ≤ Perm. prop load | OK | <input type="checkbox"/> | Not OK <input type="checkbox"/> |
| Pouring method | | | |
| Manual | <input type="checkbox"/> | Crane bucket | <input type="checkbox"/> |
| Pump | <input type="checkbox"/> | Placer boom | <input type="checkbox"/> |

3. Ensure that the shuttering/de-shuttering of the system is done as per the job site layout.

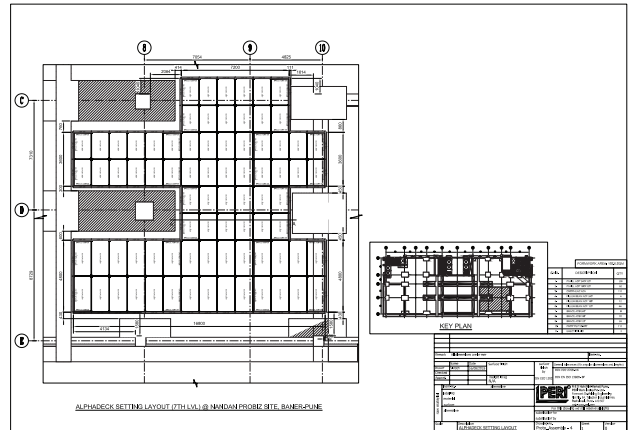

4. For working areas with shuttering height 3 m and above, choose any safe mobile scaffold.

5. It is recommended to use props upright (outer tube at bottom). Drophead fixed to base plate of inner tube.

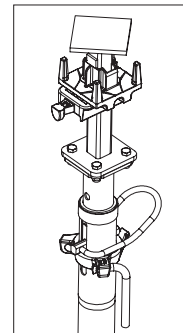

2. Check if all components (panels, dropheads, bracings, props, filler beams) are proper and not damaged.

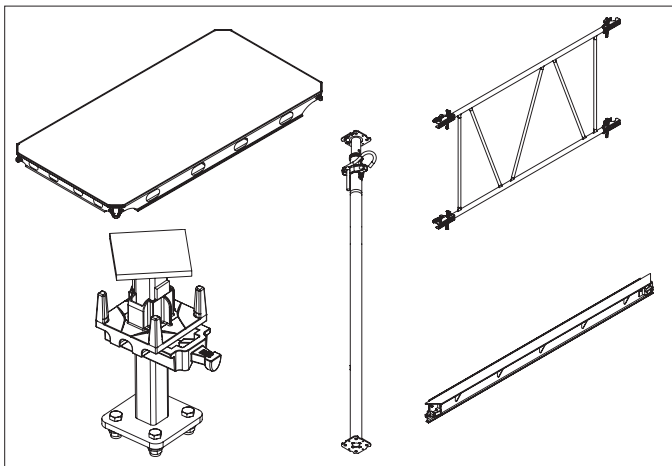

6. Check if all dropheads are firmly fixed to props using four bolts and nuts.

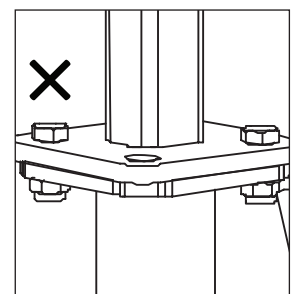
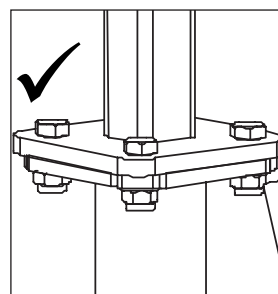

7. Check that the bolt head should be on the drophead side and nut on the prop side.

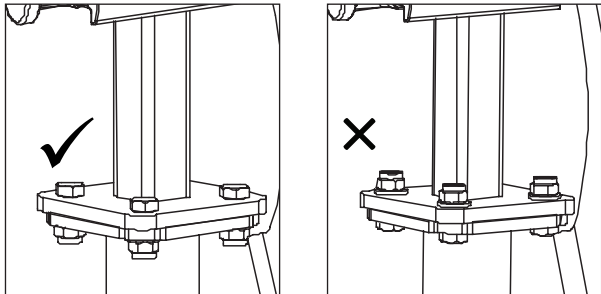
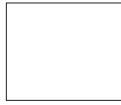

8. Before erection, ensure that all props are set to the same length as required in the project.



9. Check if wedge is tightened fully by using hammer. Check visually if the fly-plate is pressed against the stopper plate.

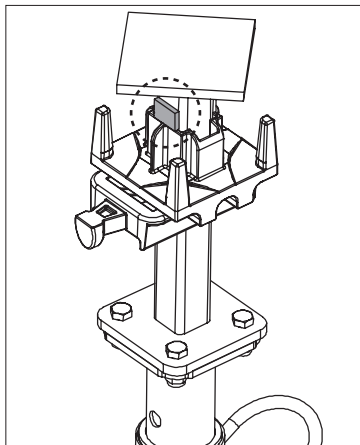

10. During installing the bracing ADB, ensure that the bottom wedge has enough clearance 30 cm from the ground for easy removal.
- Check that all the wedges of the bracing ADB are tightened.

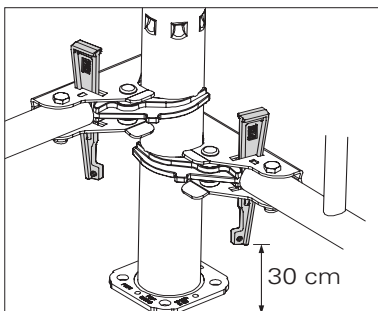

11. The first bay should have three ADB bracings (2 in shorter direction and 1 in longer direction).



- Bracings must be provided after every third bay in longer direction and every sixth bay in shorter direction. i.e. maximum of 7.2 m spacing between bracings in any direction.

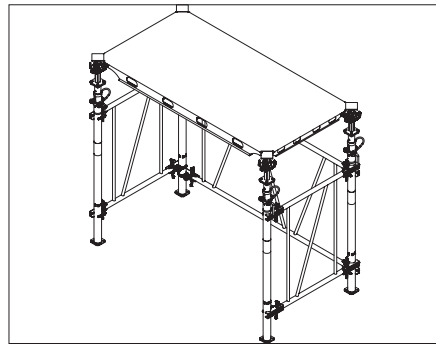

12. For all peripheral props, ensure that the wedge is perpendicular to the panel layout edge.

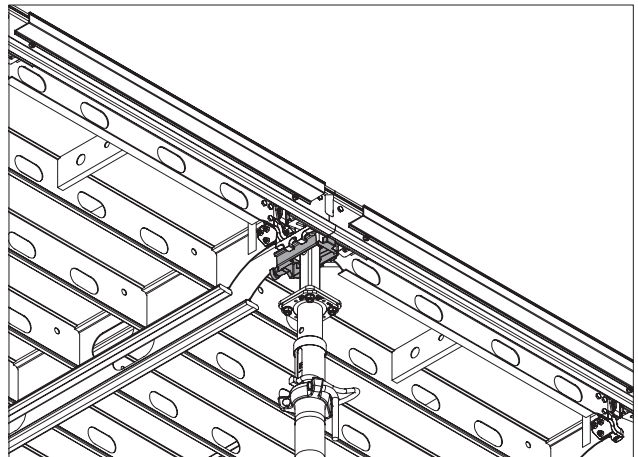

13. For all internal props, ensure that the direction of wedge is parallel to the width of the panel with its nose facing inwards. i.e. opposite to the direction of assembly

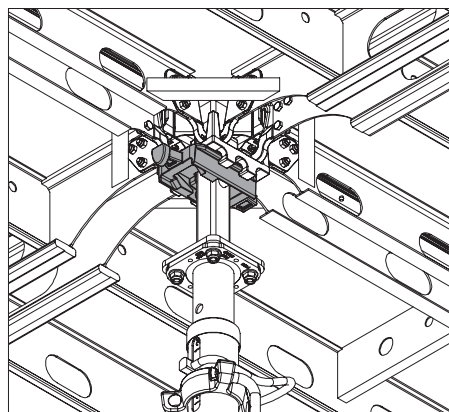

14. Minimum two shuttering aids are required for each assembly.
- Prepare the shuttering aid to the required height before starting the erection. (Prop height + 25 cm)
 - Ensure that the shuttering aid is supporting the panel at the middle edge of the panel.

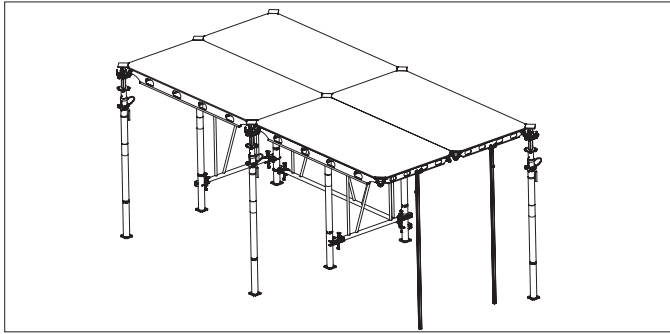

15. Ensure that the filler beam and plywood is installed properly around the ALPHADECK layout.

16. Check if all the props are loaded properly (nut seating on the pin)

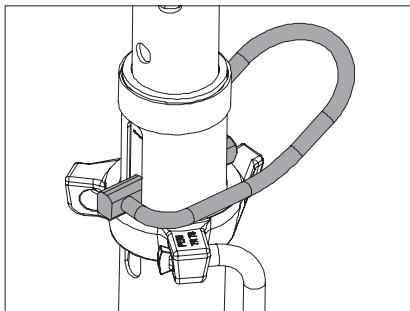

17. Check all props are vertical in both axis by using a magnetic spirit level.
- Check visually if all props are in one line in both panel length and width direction.

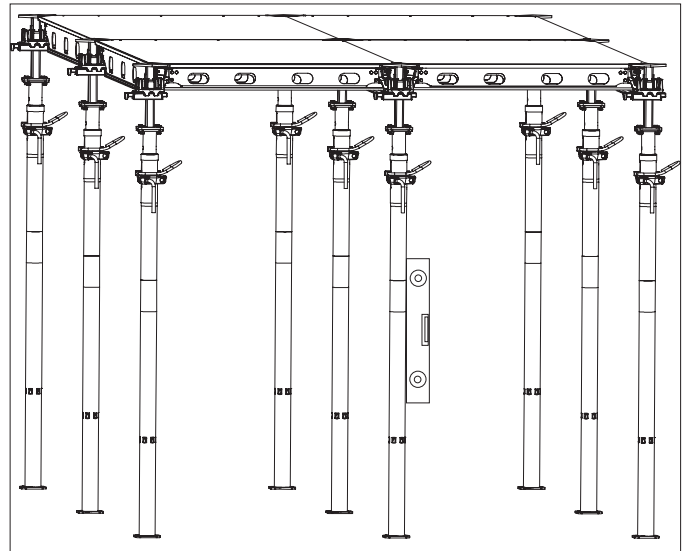

18. After the shuttering is completed, check visually from top if all the panels and drophead top plates are in the same level.

19. Check if additional bracings and chains are required. (e.g. cantilevers, open ends)

20. Do not step on formwork erected at cantilevers until it is firmly secured with Anchor chain 3.0 kN.

Special remarks (if any)

.....

.....

.....

.....

.....

.....

.....

.....

Checked by

Name & Signature:

Date:

Place:

Transverse and Longitudinal Infills

Max. infills up to 60 cm.



Warning

Risk of falling!

⇒ Personnel could fall down if edges, infills or openings in the slab formwork are not secured!

Forming the infills between 12.5 cm and 60 cm

1. Form the slab with Panel ADP (1) as far as possible, see Section A5 - Shuttering.
2. Keep the compensation area as small as possible.
 - The filler beam ADF (8) is compatible for plywood thickness (t) ranging from 12 mm to 18 mm by varying the timber insert (8.3) size. (Fig. A7.01a)
 - d = depth of timber insert
 - t = plywood thickness
 - w = width of timber insert

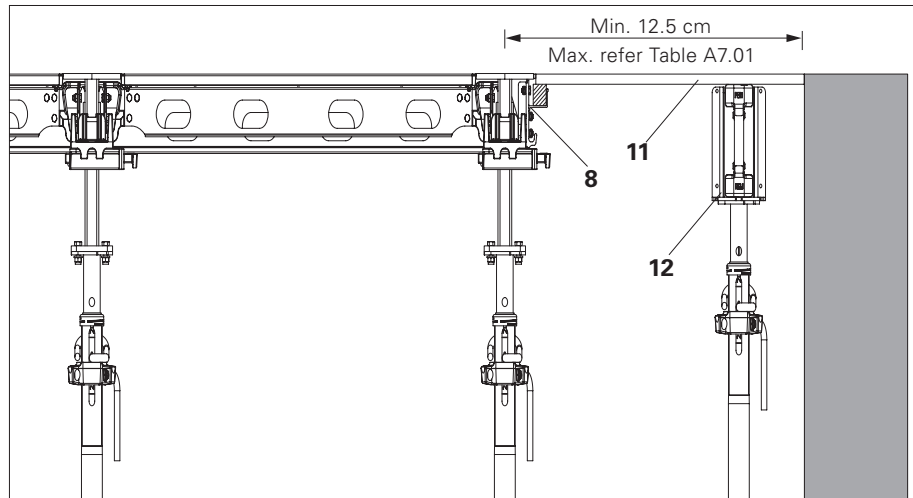

Fig. A7.01

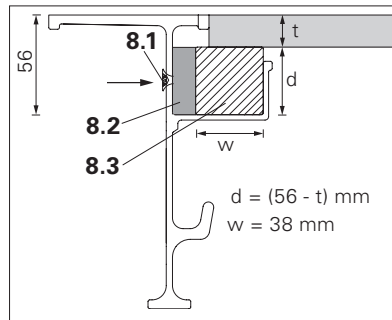

Fig. A7.01a

| Slab thickness | Max. infill width |
|----------------|-------------------|
| Up to 30 cm | 60 cm |
| 30 cm - 55 cm | 45 cm |

Table A7.01

| Filler beam sizes | Length of timber insert (8.3) |
|-------------------|-------------------------------|
| ADF 240 | 226 cm |
| ADF 180 | 166 cm |
| ADF 120 | 106 cm |

Table A7.02



- Infill size up to 60 cm and the no. of supports (12) depend on slab thickness and plywood type (E-modulus and direction of grain). This needs to be checked by contractor.
- Use torx screw 6 x 40 mm (8.1) article no. 024540 to secure the timber insert (8.3) with 12 mm packing (8.2). at every 60 cm c/c. (Fig. A7.01a)
- Timber insert (8.3) is not included in the Filler Beam ADF (8).

3. Place the Filler Beam ADF (8) on the drophead flyplate pin. (Fig. A7.02)
4. Chose correct plywood thickness and cut to size as per the dimension required at site.
5. Erect additional prop with Crosshead and Girder VT 20 (12).
6. Continuously fill the compensation area with Plywood (11).
7. Secure the Plywood (11) on top with nails. (Fig. A7.02)
→ Do not use more than two nails per Filler Beam ADF.

Components:

-
- | | |
|-----------|---|
| 1 | Panel ADP |
| 2 | Drophead ADH |
| 8 | Filler beam ADF |
| 11 | Plywood |
| 12 | Additional prop with crosshead and Girder VT 20 |
-

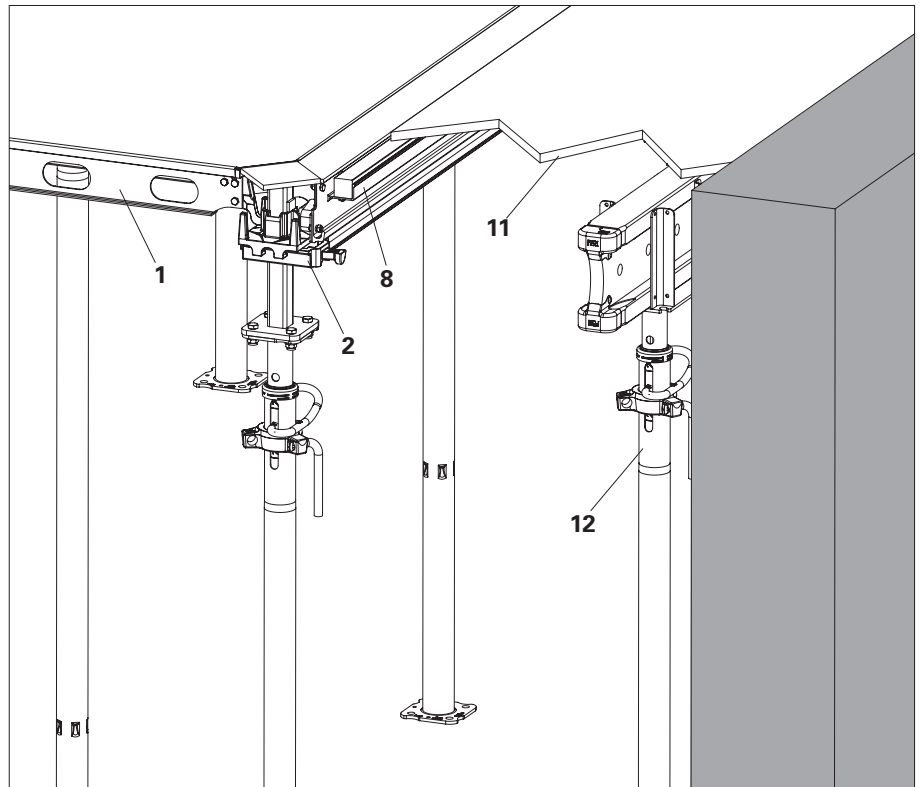

Fig. A7.02

Infill at slab panel corner

Using cross beam head and timber

1. Pre-assembly of cross beam head (13) and timber (14) size 50 x 100 mm should be done on ground.
 - Drill the timber (14) and attach the timber to cross beam head (13) with 2 no. of bolts and nuts (M10 x 80) (13.1) (Article no. 710593 and 710234) on each side. (Fig. A7.04), (Fig. A7.05) and (Table A7.02).
2. Always fix the filler beam ADF (8) parallel to the longer direction.
3. Fix the cross beam assembly parallel to the shorter direction with one end on the lip of the filler beam ADF (8) as shown in detail A and other end on the pin of the flyplate (2.2) of the drophead ADH (2) as shown in detail B. (Fig. A7.04)
5. The assembly is now in position.



- The maximum slab thickness at the infill location to be in accordance with (Table A7.03).

| Maximum slab thickness allowed for filler beam | |
|---|-------|
| ADF 180 | 40 cm |
| ADF 240 | 30 cm |
| Provide extra middle supports beneath the cross beams if slab thickness exceeds mentioned values. | |

Table A7.03

- The capacity of cross beam head is 3kN.
- The design of the filler area depends on slab thickness, infill width and plywood type (E-modulus and direction of grain). Refer (Table A7.04)
- This needs to be checked by the contractor. For any support, consult the PERI design engineer.

| | | |
|---|-------|-------|
| t | 12 mm | 18 mm |
| a | 38 mm | 32 mm |

Table A7.04

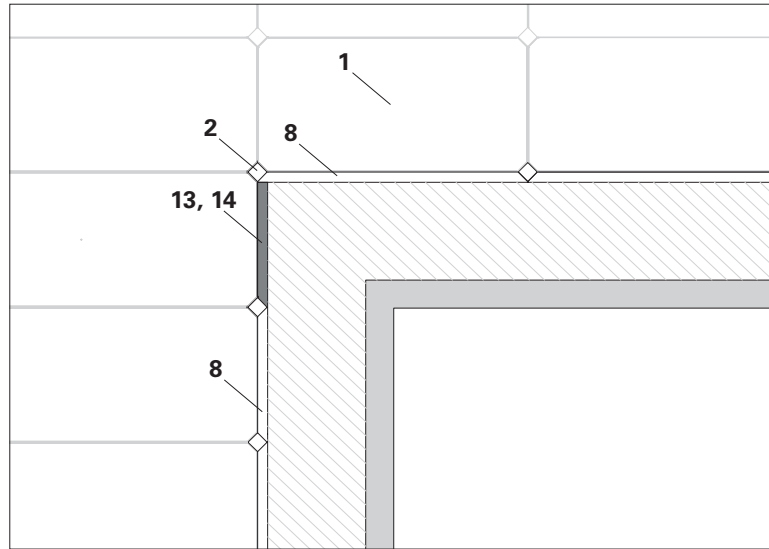

Fig. A7.03

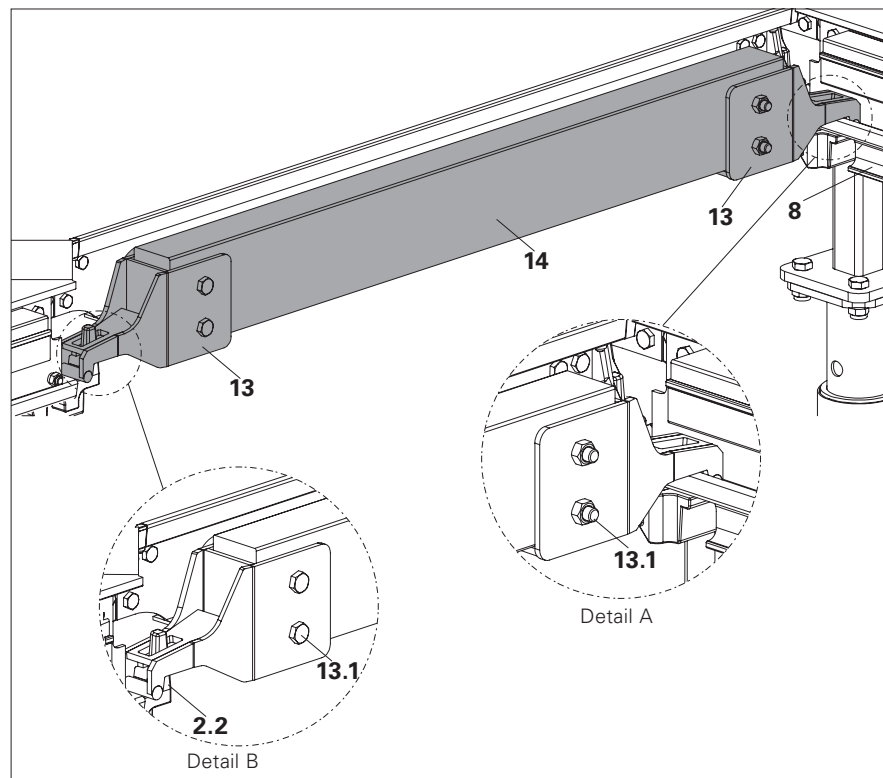

Fig. A7.04

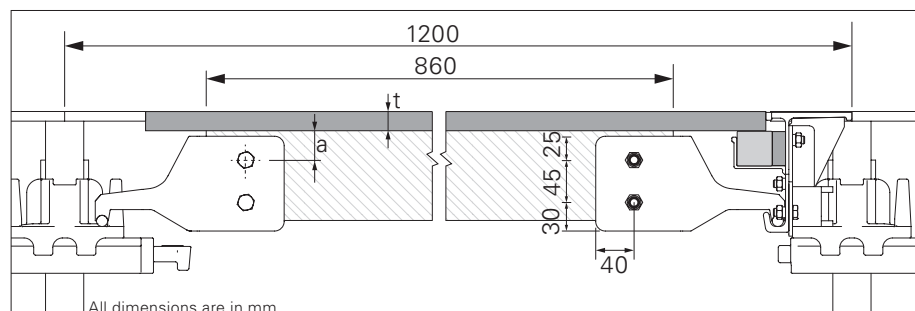

Fig. A7.05

Infill at wall internal corner

Using filler beam ADF and timber

ALPHADECK system can be started at the wall internal corner location using filler beam ADF (8) that touches the wall face in both directions.

Assembly

1. Cut an infill plywood of 36 mm width and length = filler beam length (for e.g. 180 cm for ADF 180) and nail it to the timber infill (8.3) of the filler beam ADF (8). (Fig. A7.05 + Fig. A7.06)
 - Make such similar filler beam assemblies as per project requirements.
2. Prepare a timber block (23) as per dimension shown. Height of timber H (in mm) = 120 - plywood thickness (Fig. A7.07)
3. Assemble the timber block (23) on flyplate pin of the drophead (2) at corner position and lock the wedge. (Fig. A7.06)
4. Erect the prop (3) attached with drophead (2) and timber block (23) at the wall corner in such a way that the timber block (23) touches the wall face in both directions. (Fig. A7.06)
5. Erect two other props to complete the L-shaped corner and fix the bracings ADB. Refer to Section A5 - Shuttering.
6. Install the filler beam assemblies made as per step 1 on the flyplate pins at the same L-shaped corner.
7. Now, install the panel ADP (1) at the L-shaped corner.
8. Similarly, repeat the process along the wall lengths in both directions and complete the ALPHADECK system assembly. Refer to Section A5 - Shuttering.

Plywood cutting pattern

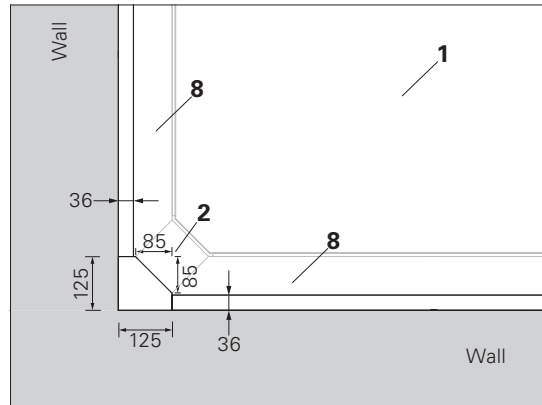

Fig. A7.05

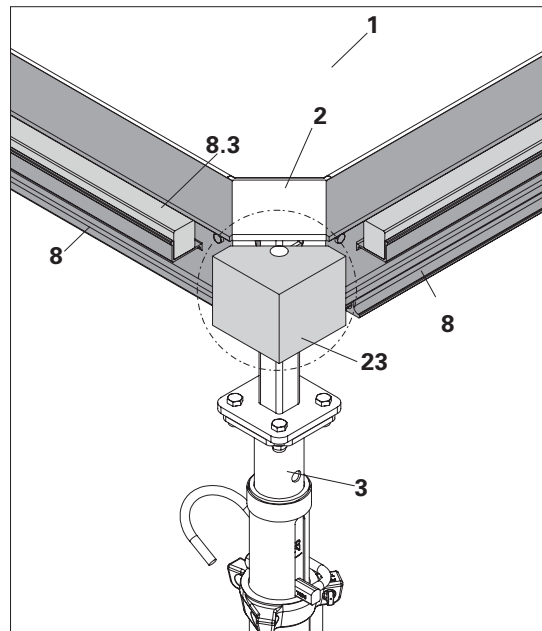

Fig. A7.06

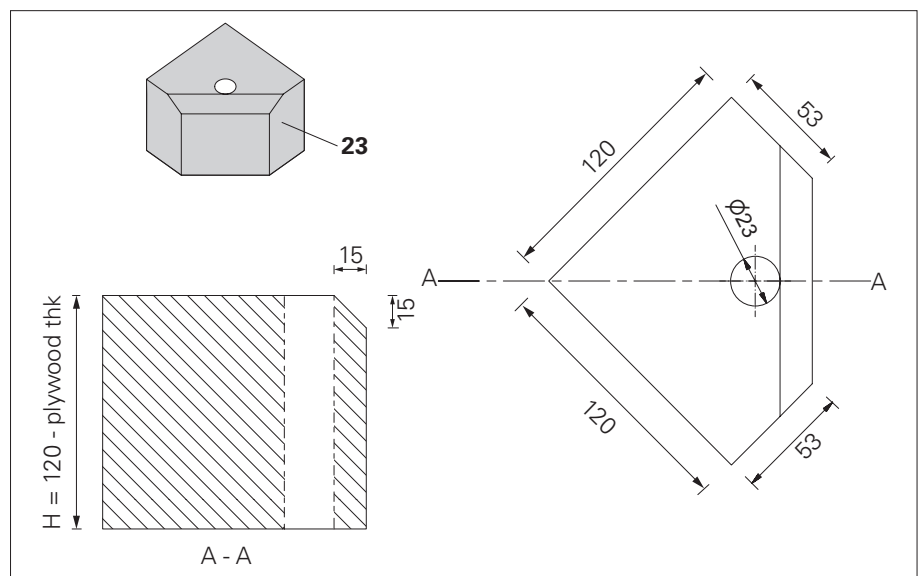

Fig. A7.07

Infill at beam internal corner

Using filler beam ADF and timber

ALPHADECK system can also be started at the beam internal corner location using filler beam ADF (8) on one side.

Assembly

1. Cut infill plywood of suitable sizes as per plywood cutting option 1 or 2. (Fig. A7.08 + Fig. A7.09)
2. Prepare a timber block (23) as per dimension shown where height of timber ($H = 120 - \text{plywood thickness}$). (Fig. A7.07 on page 29)
3. Assemble the timber block (23) on flyplate pin of the drophead (2) near to beam corner position and lock the wedge. (Fig. A7.06 on page 29)
4. Erect the prop (3) attached with drophead (2) and timber block (23) near to the beam corner (distance varies according to the infill area. for e.g. 300 mm). (Fig. A7.08 + Fig. A7.09) (alternatively timber block (23) can be installed from top)
5. Complete the ALPHADECK panel assembly. Refer to Section A5 - Shuttering.
6. Now, hook the filler beam ADF (8) on the flyplate pin and swing it using shuttering aid.
7. Similarly, repeat the process along the beam lengths in both directions near to the infill areas.
8. Complete the compensation areas on both sides as described in Transverse and Longitudinal infills (Section A7) using plywood made as per Step 1.

Plywood cutting pattern - option 1

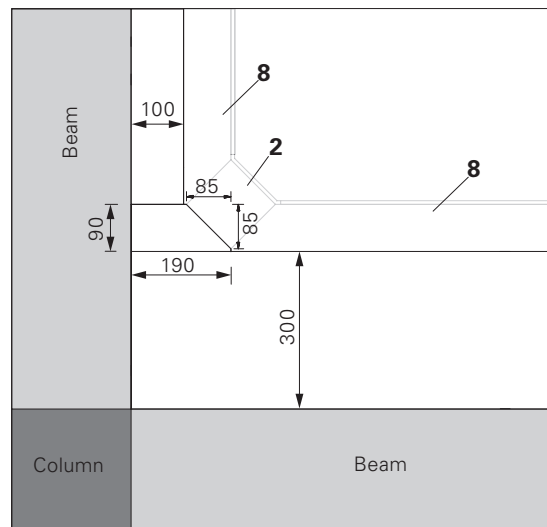

Fig. A7.08

Plywood cutting pattern - option 2

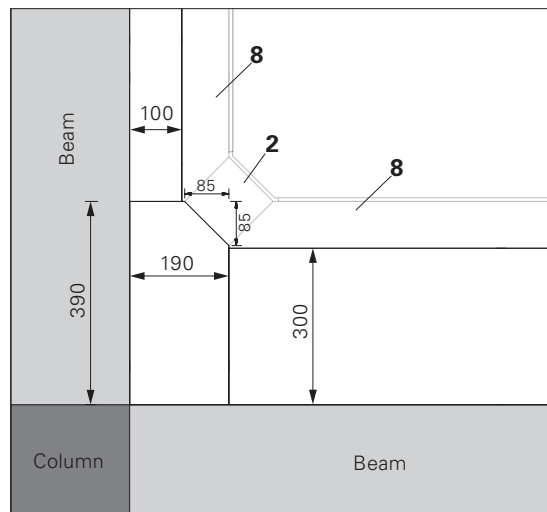

Fig. A7.09



- Infill size and the no. of support depends on slab thickness and plywood type (E-modulus and direction of grain). This needs to be checked by contractor.

Columns within the panel grid



Warning

Risk of falling!

⇒ Personnel could fall down if edges, infills or openings in the slab formwork are not secured!

1. Form the slab with panel ADP (1) as close as possible to the column.
2. Place the filler beam ADF (8) on the drophead flyplate pin in the longer direction. (Fig. A8.01)
3. Cut the timber (14) size 50 x 100 mm as per required length.
4. Pre-assembly of cross beam head (13) and timber (14) size 50 x 100 mm should be done on ground. Drill the timber (14) and attach the timber to cross beam head with 2 no. of bolts and nuts (M10 x 80) (13.1) (Article no. 710593 and 710234) on each side. (Fig. A8.01a), (Fig. A8.01b) and (Table A8.02)

| | | |
|---|-------|-------|
| t | 12 mm | 18 mm |
| a | 38 mm | 32 mm |

Table A8.02



- The capacity of cross beam head is 3kN.

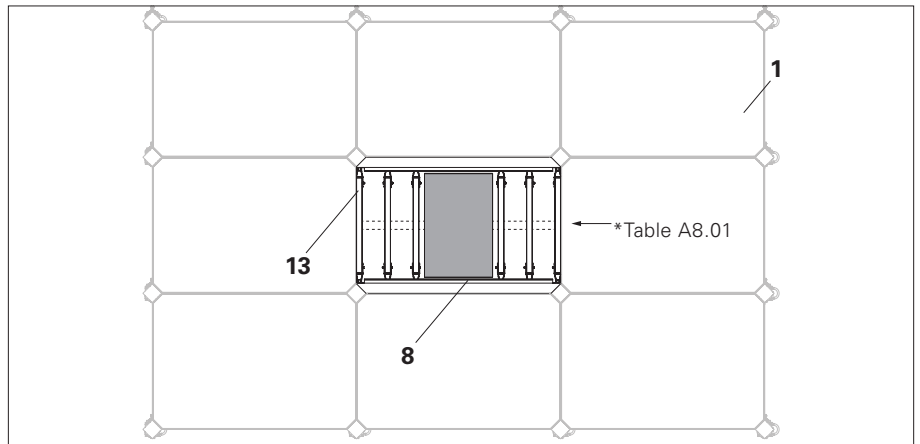

Fig. A8.01

| Maximum slab thickness allowed for filler beam | | |
|--|-------|--|
| ADF 180 | 40 cm | * Provide extra middle supports beneath the cross beams if slab thickness exceeds mentioned values |
| ADF 240 | 30 cm | |

*Table A8.01

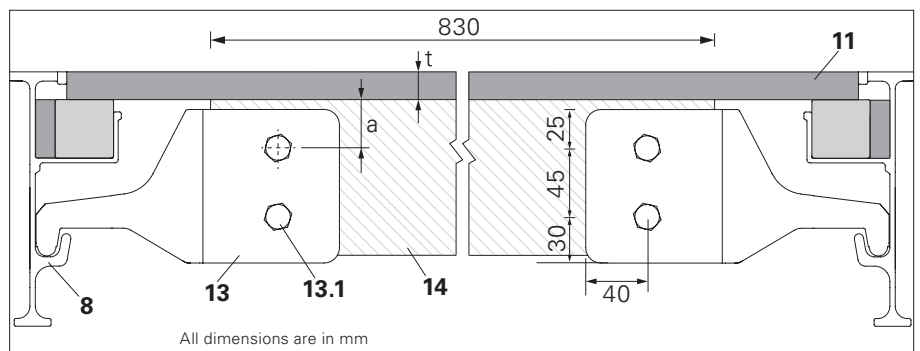

Fig. A8.01a

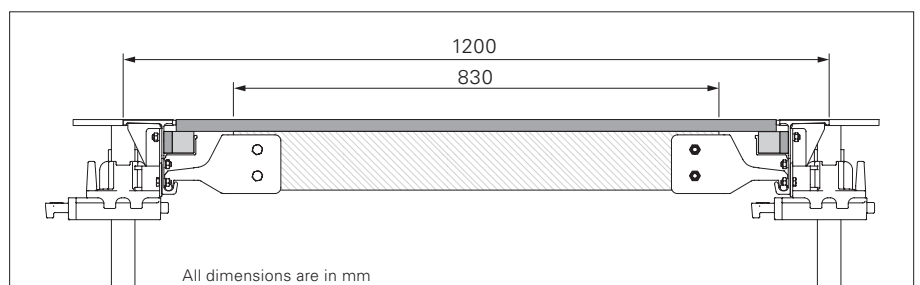

Fig. A8.01b

5. Place the assembly of cross beam head with timber into lips of the filler beam ADF (8) on both sides.
See Detail A.
6. Place similar assemblies from panel end face up to the column.
(Fig. A8.02)



- Number of cross beams and any middle supports required depend on slab thickness and plywood type (E-modulus and direction of grain). This needs to be checked by contractor.
7. Cut plywood (11) to required size.
 8. Fill the column compensation area with plywood (11).
 9. Secure the plywood on top with nails.

Components:

- | | |
|-------------|--|
| 1 | Panel ADP |
| 8 | Filler beam ADF |
| 13 | Cross beam head |
| 13.1 | Bolt and nut (M10 x 80) Article no. 710593 and 710234 |
| 14 | Timber size 50 x 100 mm |

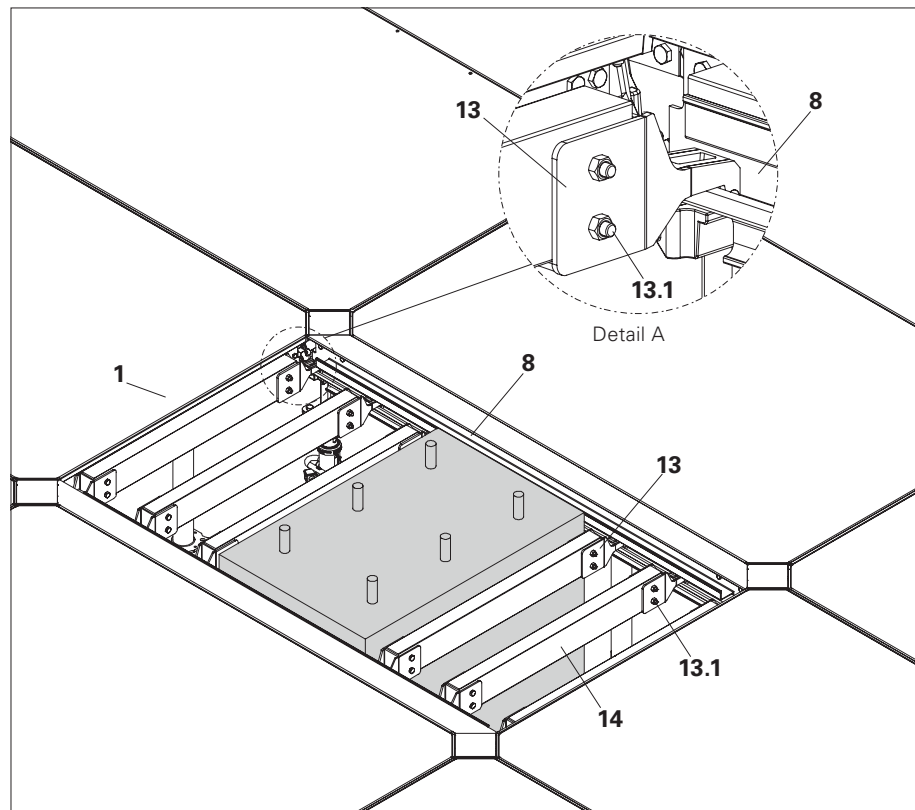

Fig. A8.02

Guardrail holder ADG with Guardrail post HSGP-2

The Guardrail holder ADG with Guardrail post HSGP-2 secures site personnel working on a casting segment against falling in both directions.

The Guardrail holder ADG can be installed in longer and shorter direction.

Design width of influence is 1.2 m for Guardrail holder ADG.



Warning

Risk of falling!
During assembly of the Guardrails, measures must be taken to prevent falling, e.g. PPE!

Assembly

1. For shorter direction:
 - Place the Guardrail holder (9) into the stiffener hole (1.8) of the panel. (Fig. A9.01)
 - Put the pin (9.1) in the same hole and lock it using cotter pin.
2. For longer direction:
 - Place the Guardrail holder (9) into the hole provided on the cross strut C (1.5) of the panel. (Fig. A9.04a)
 - Put the pin (9.1) in the same hole and lock it using cotter pin.
3. To tighten the Guardrail holder, hammer its wedge as shown in arrow mark. (Fig. A9.02)
4. Swing the panel ADP (1) along with Guardrail holder (9) upwards using Shuttering Aid (6).
5. Insert the Guardrail post HSGP-2 (10) into the Guardrail holder (9) from top. (Fig. A9.03)
 - Step on top of formwork to insert Guardrail post HSGP-2 (10) only after the system is firmly secured.
6. Insert Guardrail boards (15) and secure with nails. (Fig. A9.04)

Components:

- 9** Guardrail holder ADG
- 10** Guardrail post HSGP-2
- 15** Guardrail boards

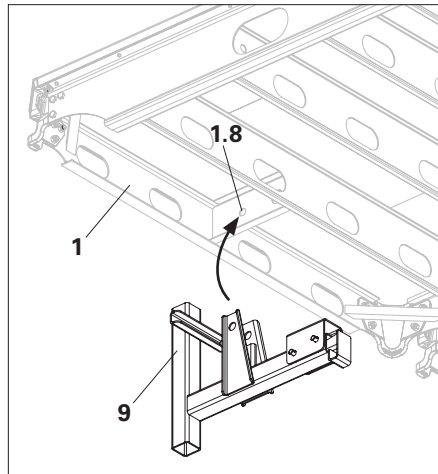

Fig. A9.01

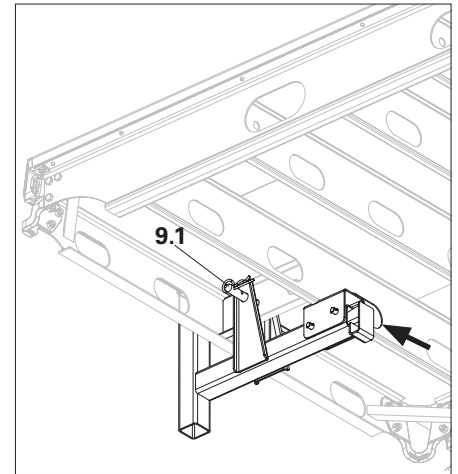

Fig. A9.02

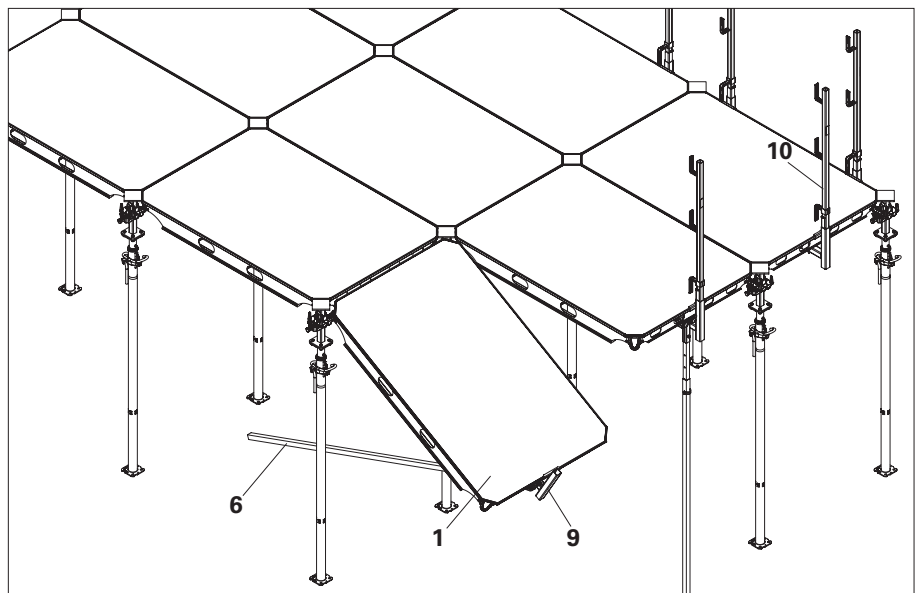

Fig. A9.03

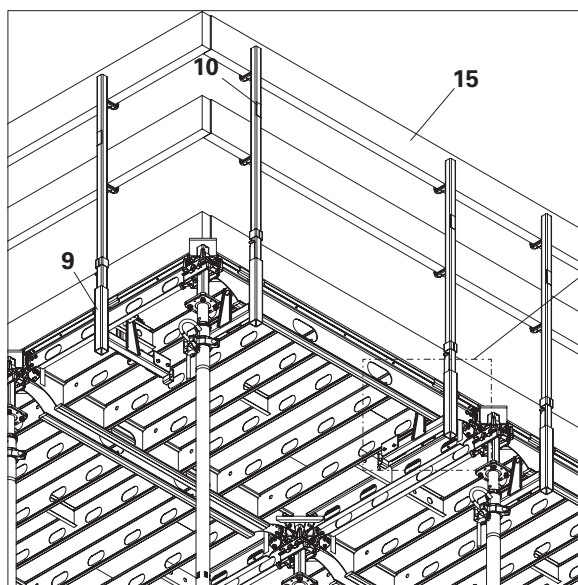

Fig. A9.04

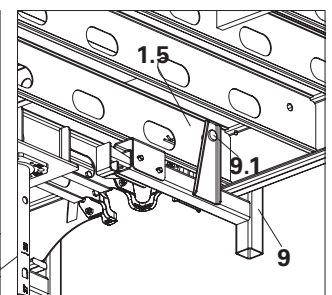

Fig. A9.04a

Cantilever in longer direction of the panel

Permissible load: 150 kg/m² on working area (W)



Information

Cantilevers are secured against toppling using anchor chain 3.0 kN (17). Additional chain bracings (17a) must be installed for transfer of horizontal loads due to open slab edges. Project specific planning is to be taken into account for the number of additional chains required. (Fig. A10.01) and (Fig. A10.02)



Warning

- Risk of falling!
- ⇒ Ensure that end-to-end side protection is installed on slabs that have been completed!
 - ⇒ Formwork erected at cantilevers must not be stepped on before being firmly secured with anchor chains and Z-bracings!
 - ⇒ Work to be carried out by qualified personnel only!

Using Panel ADP 240

Plan the projection of the slab P (20 cm max. from the prop center to the slab edge) and the width of the working area W (75 cm max.) in accordance with illustration. (Fig. A10.01a)

Using Panel ADP 180

Plan the projection of the slab P (15 cm max. from the prop center to the slab edge) and the width of the working area W (60 cm max.) in accordance with illustration. (Fig. A10.02a)

Assembly

1. Install the Panel ADP (1) along with Guardrail holder ADG (9). (Fig. A10.01)
2. Attach Crosshead ADC (16) with prop to support the Panel ADP (1).
3. Secure the cantilever using anchor chain 3.0 kN (17). (Fig. A10.01 + Fig. A10.02)
 - Attach the anchor chain (17) to the hole (1.9) provided on stiffener (1.6) of the Panel ADP (1). (Fig. A10.02b)
4. Install additional Z-bracings for stability of props at periphery. e.g. bracings using pipes and couplers. (Fig. A10.01 + Fig. A10.02)

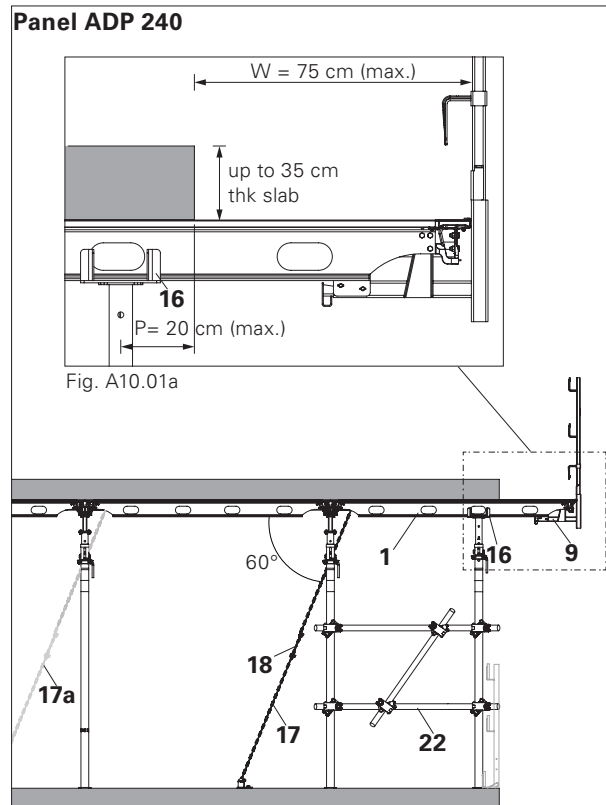

Fig. A10.01

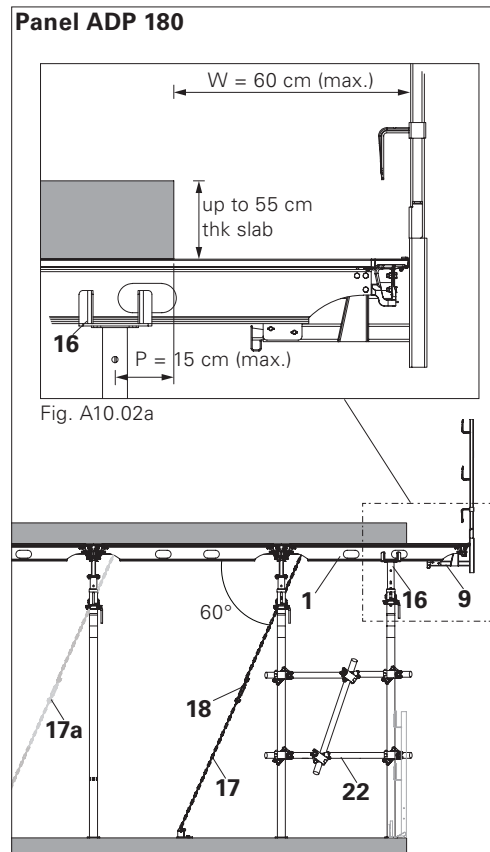

Fig. A10.02

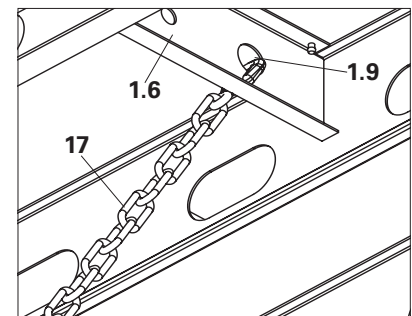

Fig. A10.02b

5. Insert the Guardrail post HSGP-2 (10) into the Guardrail holder (9) from top only after it is firmly secured with anchor chains. (Fig. A10.03)
6. Insert Guardrail boards (15) and secure with nails. (Fig. A10.03)

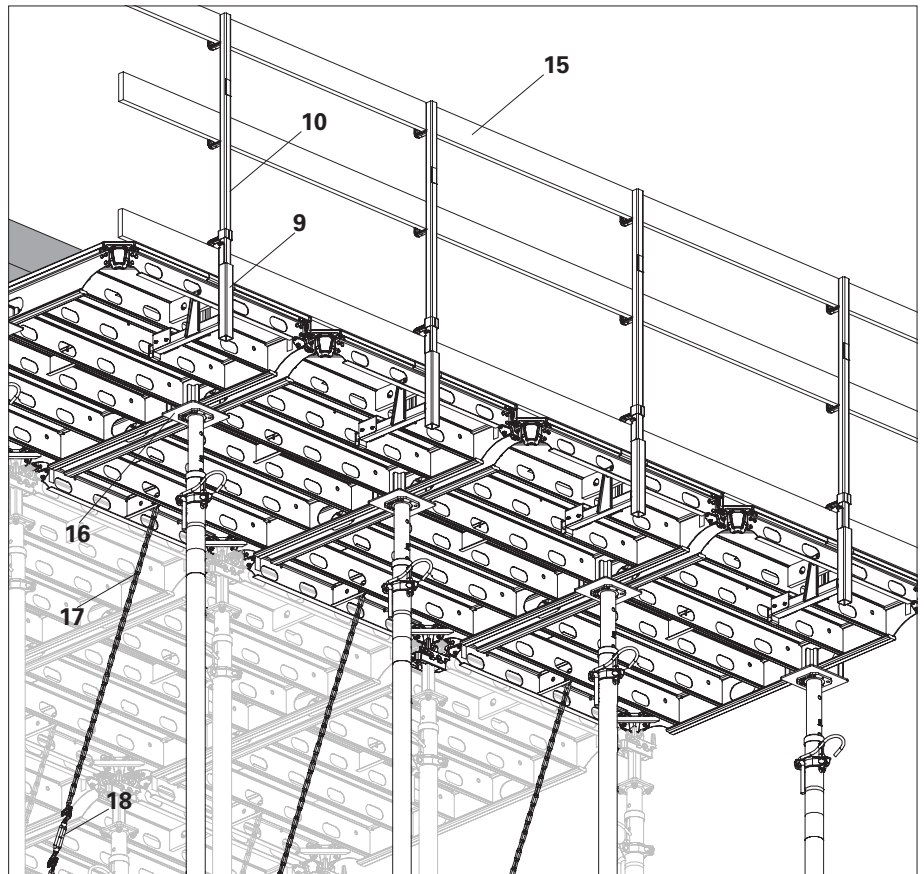

Fig. A10.03

Tensioning using anchor chain 3.0 kN

1. Mount RS base plate (19) on the existing construction with the PERI anchor bolt 14/20 x 130 (21). Bracing angle 60°. (Fig. A10.04)
2. Attach the 3.0 kN anchor chain (17) to the 3.0 kN turnbuckle (18) and attach the 3.0 kN turnbuckle (18) to the RS base plate.
 - In case of longer lengths, use two anchor chains connected with turn buckle in the middle.
3. Tighten the turnbuckle (18) until the anchor chain is taut using pins and cotter pins (20). (Fig. A10.04)

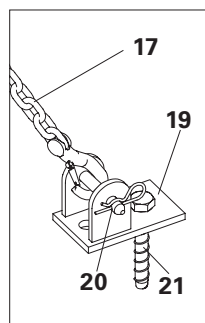

Fig. A10.04

Cantilever in shorter direction of the panel

Permissible load: 150 kg/m² on working area (W)



Information

Cantilevers are secured against toppling using anchor chain 3.0 kN (17). Additional chain bracings (17a) must be installed for transfer of horizontal loads due to open slab edges. Project specific planning is to be taken in to account for the number of additional chains required. (Fig. A10.05)



Warning

- Risk of falling!
- ⇒ Ensure that end-to-end side protection is installed on slabs that have been completed!
 - ⇒ Formwork erected at cantilevers must not be stepped on before being firmly secured with anchor chains and Z-bracings!
 - ⇒ Work to be carried out by qualified personnel only!

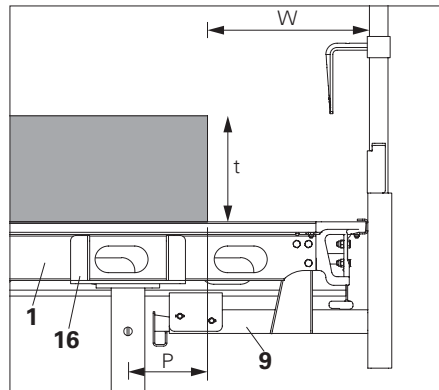

Fig. A10.05a

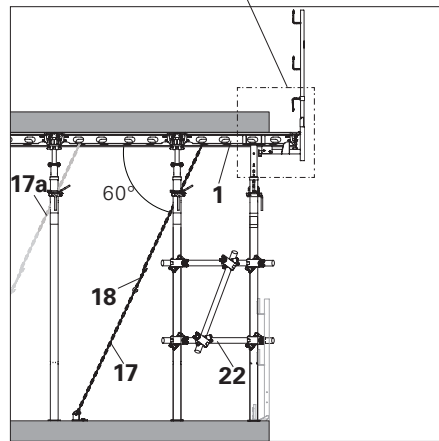

Fig. A10.05

| Panel ADP 240 | | |
|--------------------|-----|-----|
| Slab thickness | W | P |
| $t \leq 250$ | 300 | 100 |
| $250 < t \leq 350$ | 200 | 60 |

Table A10.01

| Panel ADP 180 | | |
|--------------------|-----|-----|
| Slab thickness | W | P |
| $t \leq 400$ | 300 | 100 |
| $400 < t \leq 550$ | 150 | 100 |

Table A10.02

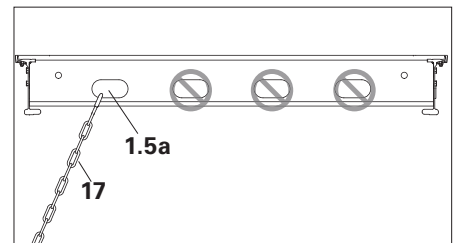

Fig. A10.05b

Using Panel ADP 240

Plan the projection of the slab P (from the prop center to the slab edge) and the width of the working area W in accordance with (Fig A10.05a) and (Table A10.01)

Using Panel ADP 180

Plan the projection of the slab P (from the prop center to the slab edge) and the width of the working area W in accordance with (Fig A10.05a) and (Table A10.02)

Assembly

1. Install the Panel ADP (1) along with Guardrail holder ADG (9). (Fig. A10.05a)
2. Attach Crosshead ADC (16) with prop to support the Panel ADP (1).
3. Secure the cantilever using anchor chain 3.0 kN (17). (Fig. A10.05)
 - Attach anchor chain (17) only on the first slot (1.5a) provided on the outermost cross strut C of the Panel ADP (1) (Fig. A10.05b)
4. Install additional Z-bracings (22) for stability of props at periphery. e.g. bracings using pipes and couplers. (Fig. A10.05)

Panel ADP 240

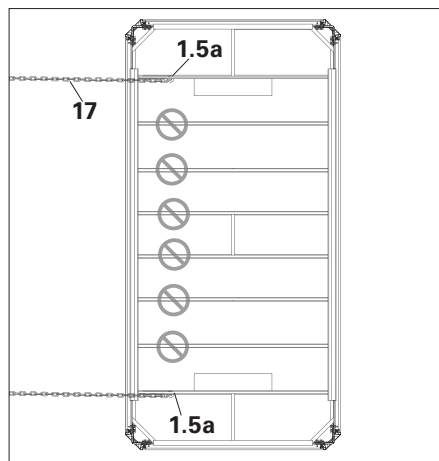

Fig. A10.06



Use two no. of chains per panel as shown in illustration. (Fig. A10.06 + Fig. A10.07)

Panel ADP 180

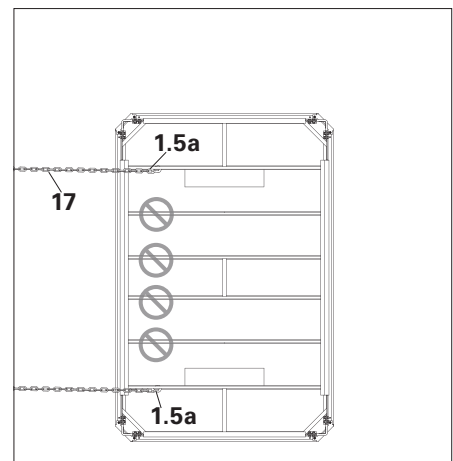

Fig. A10.07



Do not attach the anchor chain 3.0 kN (17) on any place other than the first slot (1.5a) provided on the outermost cross strut C of the panel. (Fig. A10.05a), (Fig. A10.06), and (Fig. A10.07) .

5. Insert the Guardrail post HSGP-2 (10) into the Guardrail holder (9) from top only after it is firmly secured with anchor chains. (Fig. A10.08)
6. Insert Guardrail boards (15) and secure with nails. (Fig. A10.08)

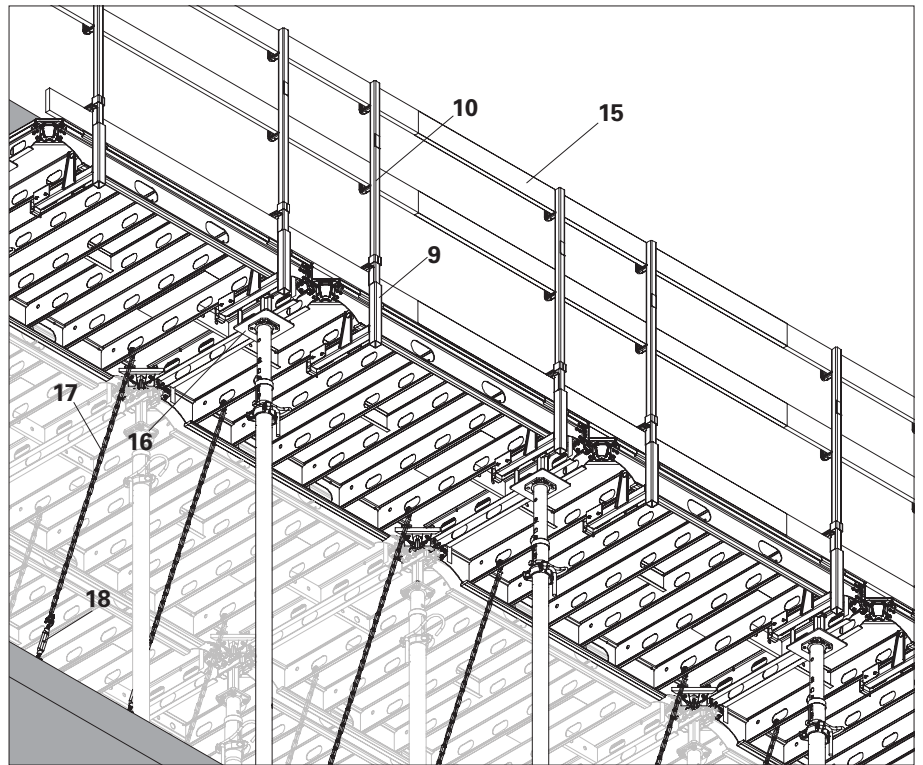

Fig. A10.08

Tensioning using anchor chain 3.0 kN

1. Mount RS base plate (19) on the existing construction with the PERI anchor bolt 14/20 x 130 (21). Bracing angle 60°. (Fig. A10.09)
2. Attach the 3.0 kN anchor chain (17) to the 3.0 kN turnbuckle (18) and attach the 3.0 kN turnbuckle (18) to the RS base plate.
 - In case of longer lengths, use two anchor chains connected with turn buckle in the middle.
3. Tighten the turnbuckle (18) until the anchor chain is taut using pins and cotter pins (20). (Fig. A10.09)

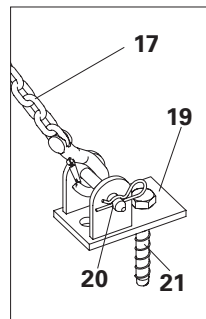

Fig. A10.09

When early striking is required



Warning

Risk of collapse!

Consequences of non-compliance.

⇒ Deshuttering to start only when the concrete has sufficiently hardened and the person in charge has given the go-ahead for striking to take place.



- Deshuttering of the system should start from infill areas.
- Striking is carried out by means of a safe mobile scaffold.
- Before commencement of deshuttering, all bracings should be removed and stacked properly.

Deshuttering the Filler beam ADF

1. Get access to the safe infill areas.
2. Strike the drophead wedge with a hammer at infill corner. This causes the Filler beam ADF to drop by 12 cm.
3. Remove the Filler beam ADF.

Lowering of the panels

1. Strike the drophead wedge with a hammer. (Fig. A11.01)
2. Strike the next drophead wedge on one side row by row as shown by arrow mark. This causes the panels to drop by 12 cm. (Fig. A11.02)
3. Similarly, release all the wedges as shown in step 1 & 2.

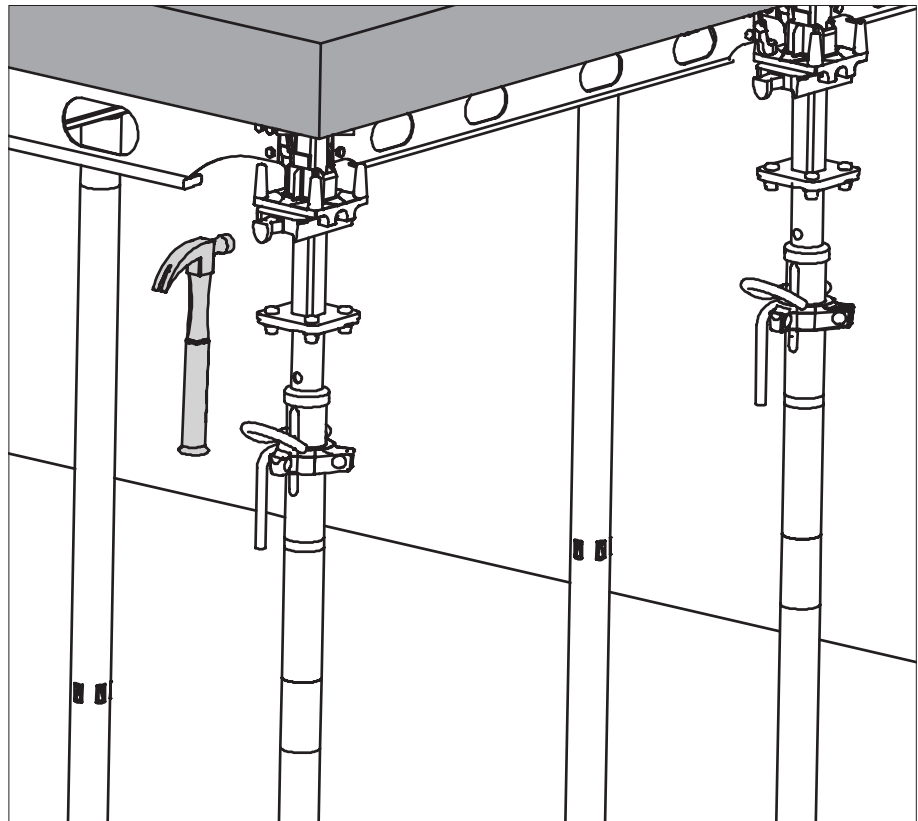

Fig. A11.01

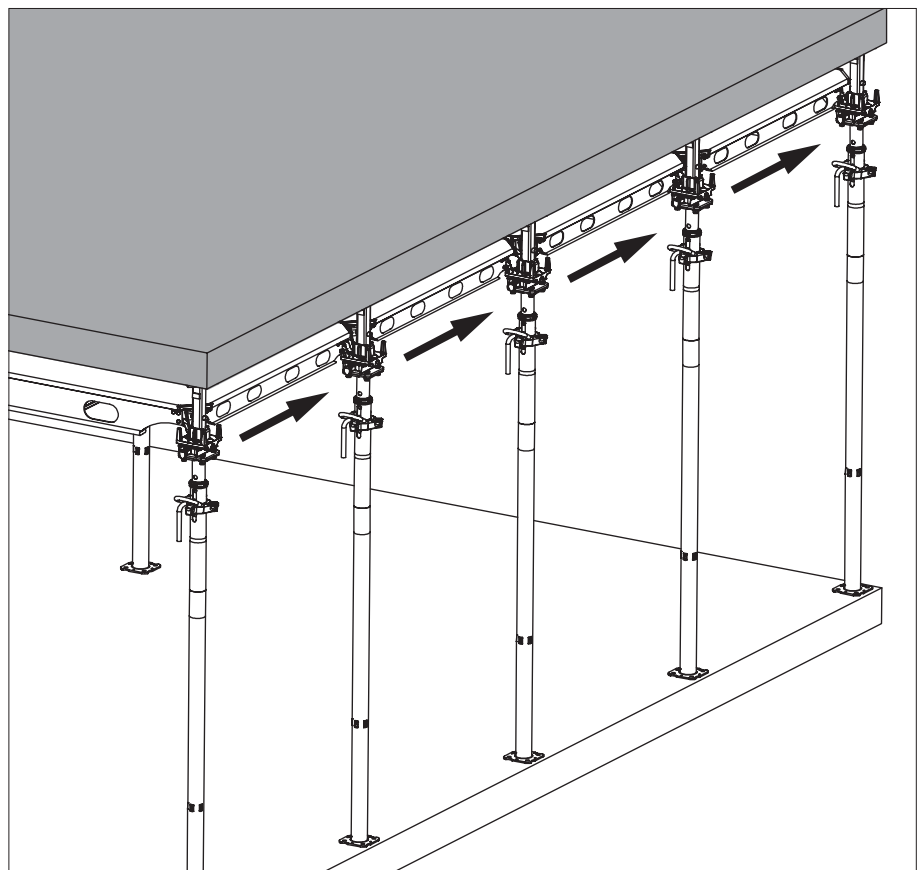

Fig. A11.02

After striking all the wedges by hammer, the panels are now released from the concrete surface. (Fig. A11.03)

This allows easy de-shuttering of panels in both shorter and longer directions.

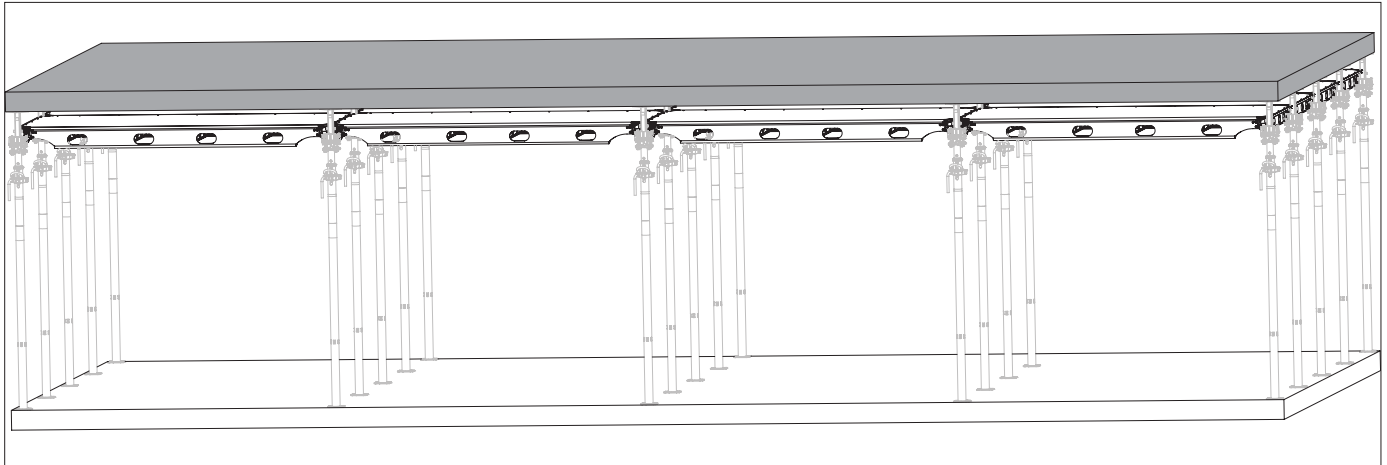

Fig. A11.03

Removing the panels in longer direction



Use safe mobile scaffold while removing the panels.

1. To remove the panel from its position, lift the panel from flyplate pin.
2. Push the panel horizontally till the panel clears the flyplate pin by 30 mm.
3. Tilt the panel and bring it to the ground.
See sequence shown in detail A.

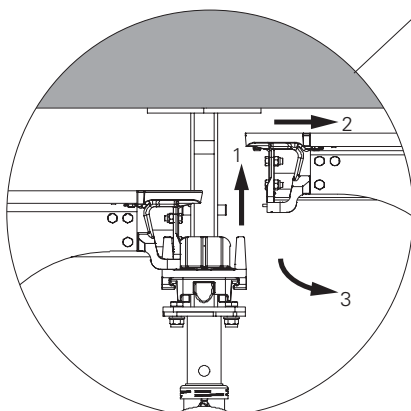

Detail A

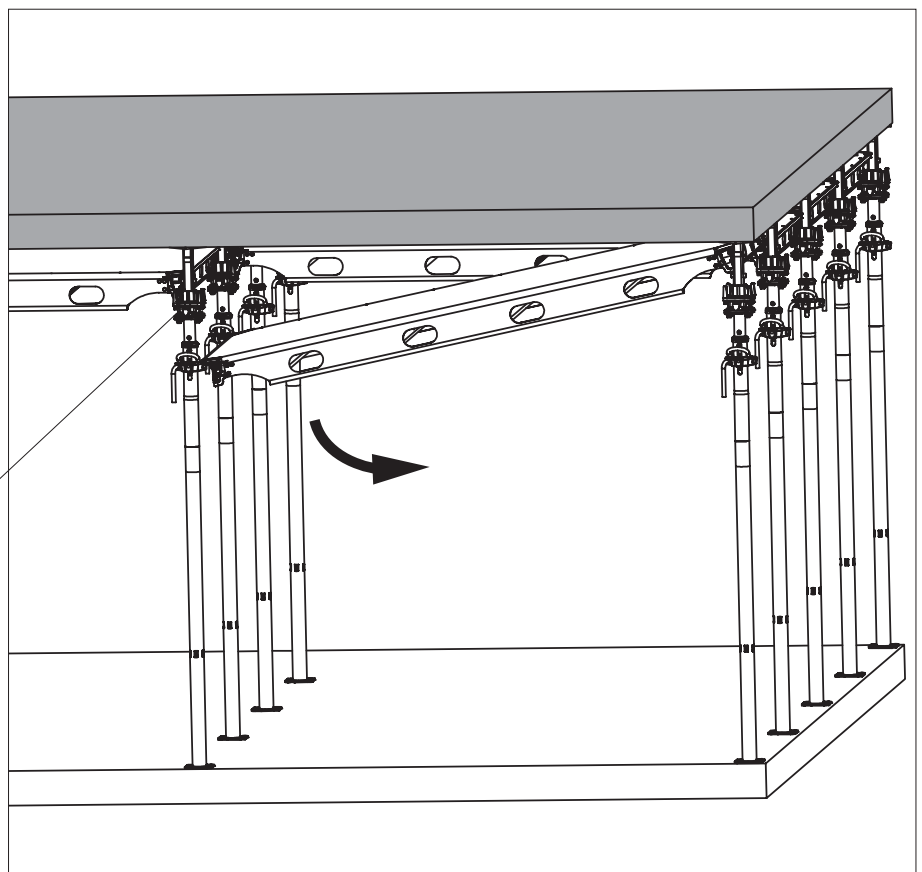

Fig. A11.04

Removing the panels in shorter direction

1. Similarly, to remove the panel in shorter direction, lift the panel from fly-plate pin. (Fig. A11.05)
2. Push the panel aside and then tilt it to lower it to the ground.

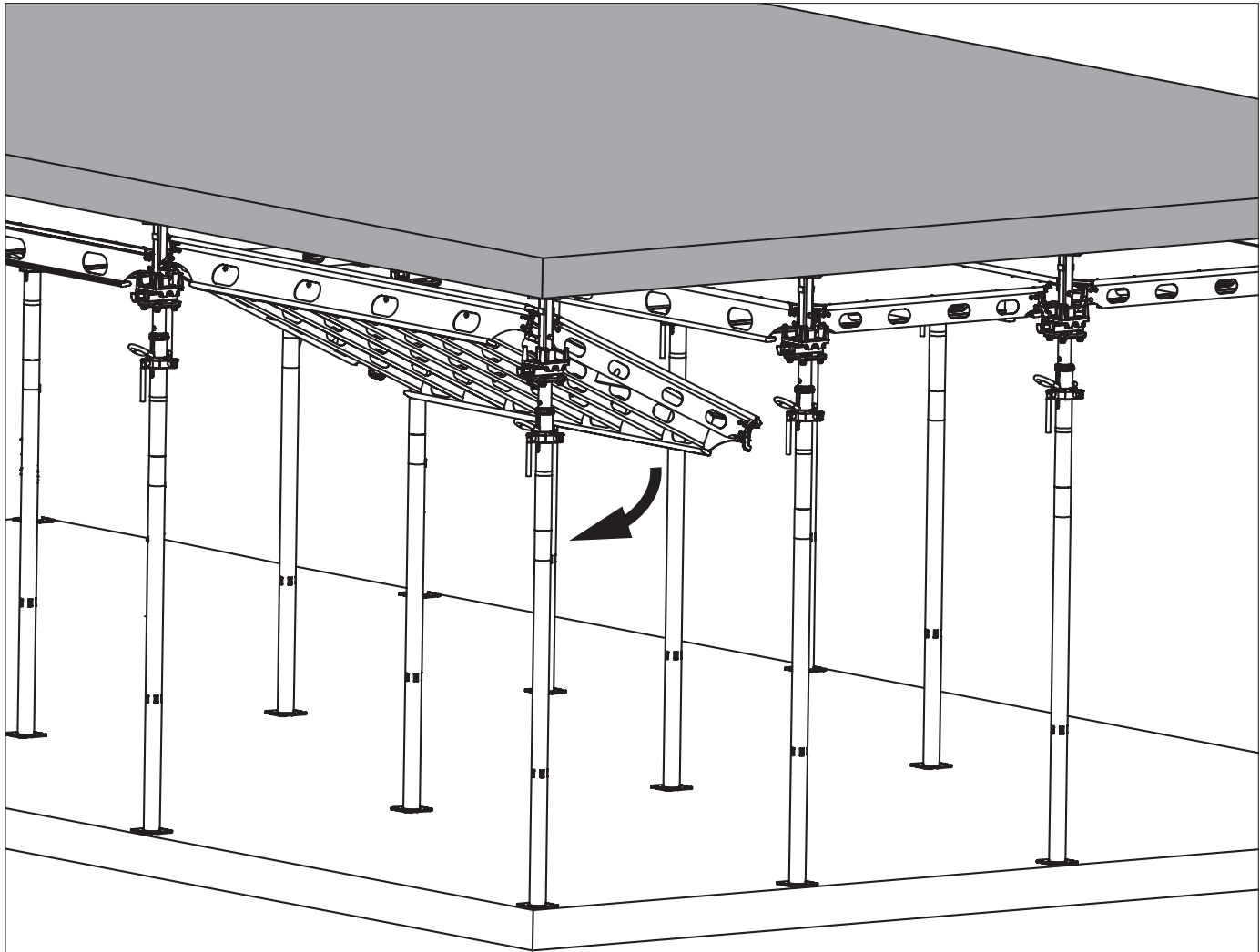

Fig. A11.05



Always ensure while tilting and lowering the panel in any direction, it should rotate towards the free end.

Once all the panels are removed, the prop with dropheads remain undisturbed. (Fig. A11.06)

After reaching the required concrete strength

- Remove the prop with dropheads and store in pallets.

Cleaning

Before next shuttering, clean ALPHADECK components and panel edges and spray once again, e.g. with PERI Bio Clean.
See introduction "Cleaning and maintenance".

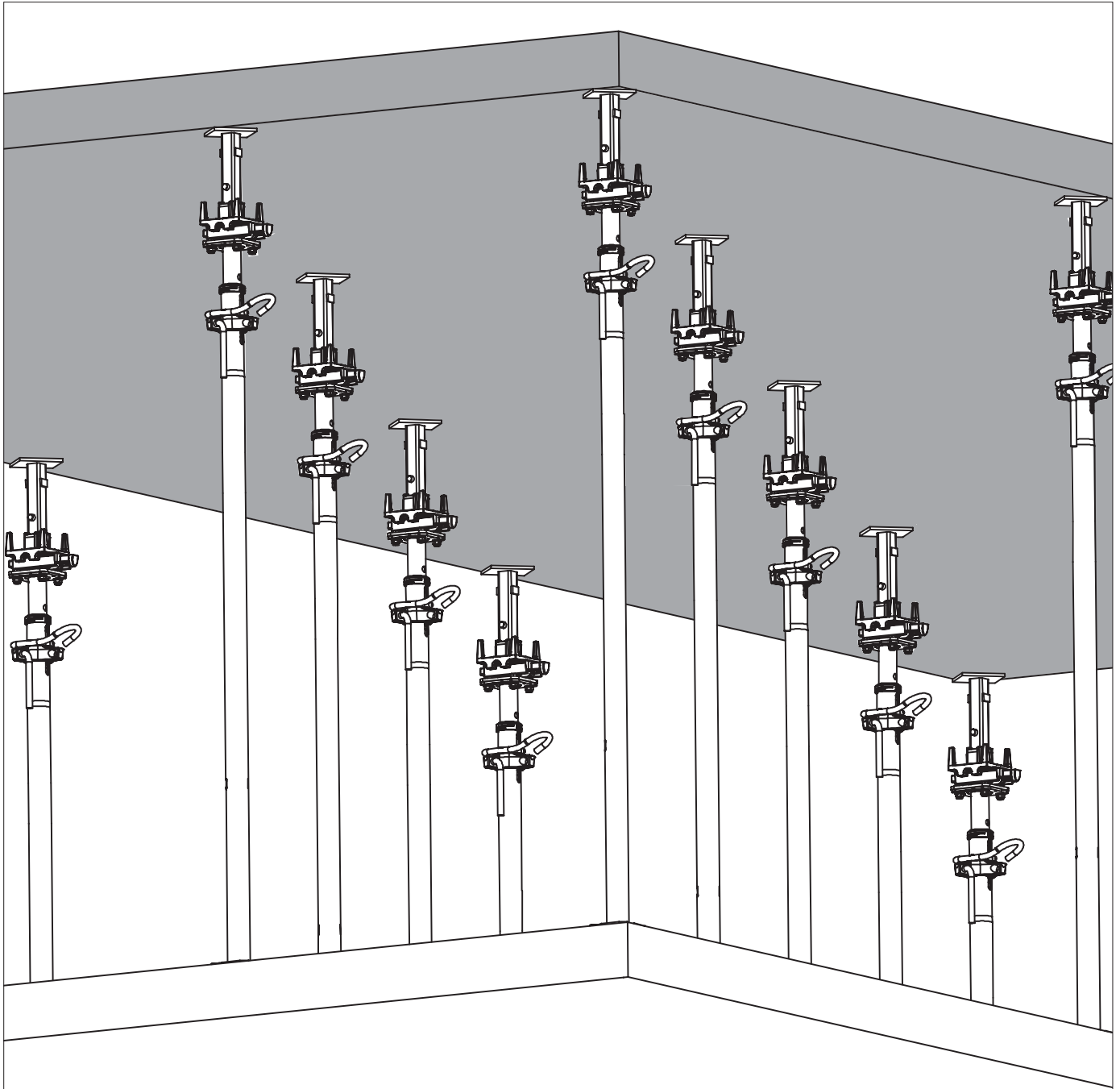

Fig. A11.06

When early striking is not required



Warning

Risk of collapse!

⇒ Deshuttering to start only when the concrete has sufficiently hardened and the person in charge has given the go-ahead for striking to take place.



- As a general rule, the striking process should be carried out by reversing the shuttering process.
- Striking is to be carried out by means of a safe mobile scaffold.
- Deshuttering of the system should start from infill areas.

Deshuttering

1. Support the panel edge at the middle using two shuttering aids in the shorter direction for the first two bays. (Fig. A11.07)
 - Secure shuttering aids so they cannot be knocked over.
2. Lower two props at rear side of the first panel by 2 cm followed by front props.
 - Do not lower slab props too far or the panels will no longer hold them in place and they will become unstable.
3. Remove the outside props keeping the shuttering aid in position.
 - Always secure panels that are not held in place by 4 slab props with a shuttering aid.
4. Swivel down the first panel using shuttering aid and then remove the panel.
5. Repeat this process to complete the deshuttering.

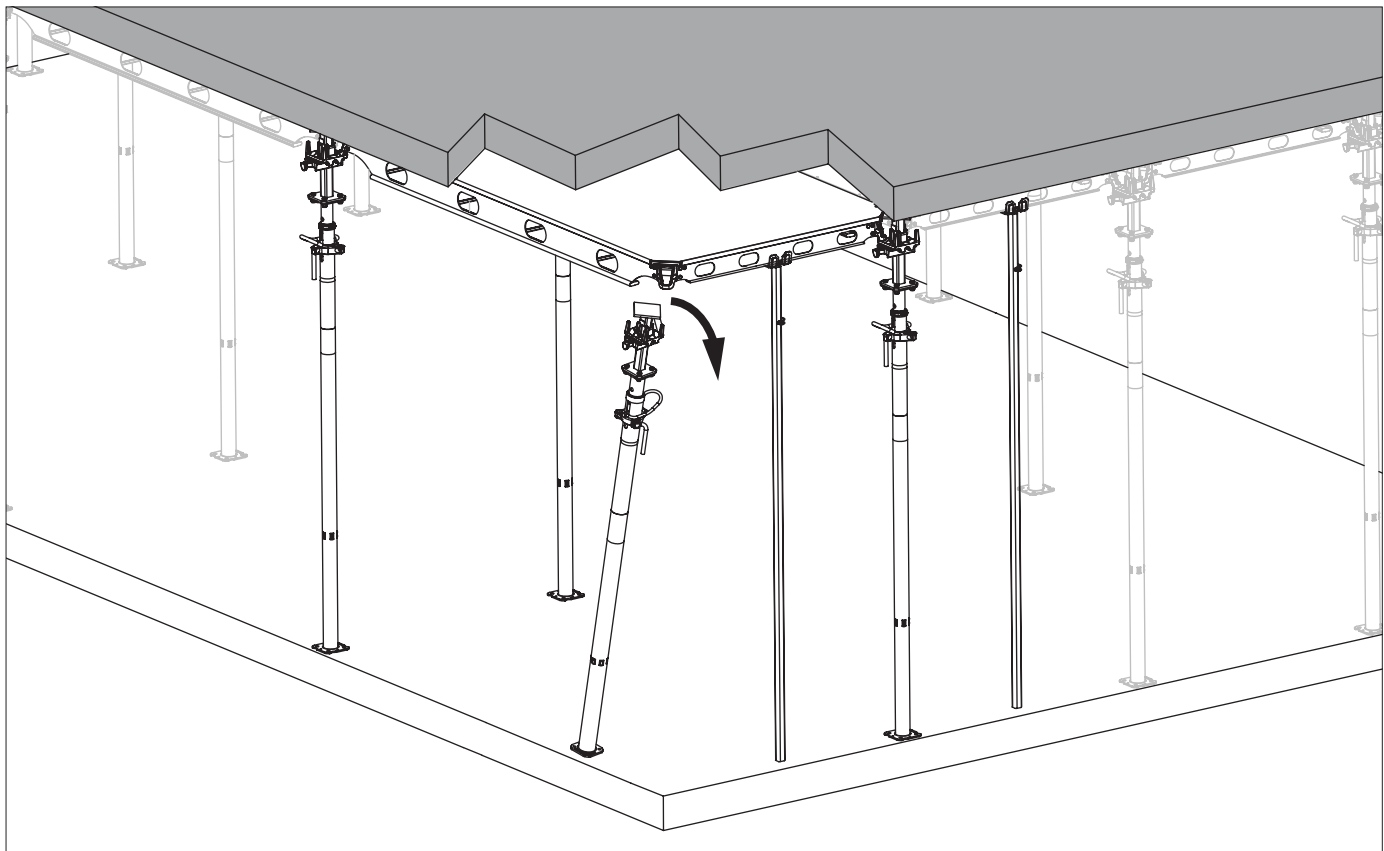

Fig. A11.07

Load charts for slab props

PEP 20

Permissible prop load [kN]

| Extension length [m] | PEP 20 N 260* L = 1.51 – 2.60 m | | PEP 20-300 L = 1.71 – 3.00 m | | PEP 20-350 L = 1.96 – 3.50 m | | PEP 20-400 L = 2.21 – 4.00 m | | PEP 20-500 L = 2.71 – 5.00 m | |
|----------------------|------------------------------------|-------------------|---------------------------------|-------------------|---------------------------------|-------------------|---------------------------------|-------------------|---------------------------------|-------------------|
| | Outer tube bottom | Inner tube bottom | Outer tube bottom | Inner tube bottom | Outer tube bottom | Inner tube bottom | Outer tube bottom | Inner tube bottom | Outer tube bottom | Inner tube bottom |
| | 1.60 | 35.0 | 35.0 | | | | | | | |
| 1.70 | 35.0 | 35.0 | | | | | | | | |
| 1.80 | 35.0 | 35.0 | 36.4 | 36.4 | | | | | | |
| 1.90 | 35.0 | 35.0 | 36.4 | 36.4 | | | | | | |
| 2.00 | 33.5 | 35.0 | 36.1 | 36.4 | 36.4 | 36.4 | | | | |
| 2.10 | 31.9 | 35.0 | 33.2 | 36.4 | 36.4 | 36.4 | | | | |
| 2.20 | 30.9 | 35.0 | 31.4 | 36.4 | 36.4 | 36.4 | | | | |
| 2.30 | 29.8 | 35.0 | 29.9 | 36.4 | 36.4 | 36.4 | 36.4 | 36.4 | | |
| 2.40 | 28.6 | 35.0 | 28.7 | 36.4 | 36.4 | 36.4 | 36.4 | 36.4 | | |
| 2.50 | 27.1 | 32.1 | 27.7 | 36.4 | 36.4 | 36.4 | 36.4 | 36.4 | | |
| 2.60 | 24.8 | 29.4 | 26.9 | 34.7 | 34.8 | 36.4 | 36.4 | 36.4 | | |
| 2.70 | | | 25.7 | 31.7 | 33.4 | 36.4 | 36.4 | 36.4 | | |
| 2.80 | | | 24.0 | 28.9 | 32.1 | 36.4 | 36.4 | 36.4 | 36.4 | 36.4 |
| 2.90 | | | 22.3 | 26.5 | 31.1 | 36.4 | 36.4 | 36.4 | 36.4 | 36.4 |
| 3.00 | | | 20.5 | 23.9 | 30.1 | 36.4 | 36.4 | 36.4 | 36.4 | 36.4 |
| 3.10 | | | | | 28.3 | 35.7 | 34.6 | 36.4 | 36.4 | 36.4 |
| 3.20 | | | | | 26.5 | 32.5 | 33.5 | 36.4 | 36.4 | 36.4 |
| 3.30 | | | | | 24.8 | 29.7 | 32.1 | 36.4 | 36.4 | 36.4 |
| 3.40 | | | | | 23.1 | 27.2 | 30.5 | 36.4 | 36.4 | 36.4 |
| 3.50 | | | | | 21.3 | 24.4 | 28.7 | 34.9 | 36.4 | 36.4 |
| 3.60 | | | | | | | 26.9 | 32.1 | 36.4 | 36.4 |
| 3.70 | | | | | | | 25.3 | 29.8 | 36.4 | 36.4 |
| 3.80 | | | | | | | 23.7 | 27.6 | 36.4 | 36.4 |
| 3.90 | | | | | | | 22.3 | 25.5 | 36.4 | 36.4 |
| 4.00 | | | | | | | 20.7 | 23.5 | 35.3 | 36.4 |
| 4.10 | | | | | | | | | 33.3 | 36.4 |
| 4.20 | | | | | | | | | 31.5 | 36.4 |
| 4.30 | | | | | | | | | 29.8 | 35.0 |
| 4.40 | | | | | | | | | 28.2 | 32.9 |
| 4.50 | | | | | | | | | 26.8 | 30.8 |
| 4.60 | | | | | | | | | 25.3 | 28.9 |
| 4.70 | | | | | | | | | 24.1 | 27.2 |
| 4.80 | | | | | | | | | 22.8 | 25.7 |
| 4.90 | | | | | | | | | 21.5 | 24.1 |
| 5.00 | | | | | | | | | 20.3 | 22.1 |

All PEP 20 Props correspond to Class D of DIN EN 1065, i. e. the permissible prop load for all extension lengths is a minimum of 20 kN.

*For the N Props, use of the inner tube at the bottom is only possible in connection with PERI Slab Tables

Load charts for slab props

PEP 30



Permissible prop load [kN]

| Extension length [m] | PEP 30-150 | | PEP 30-250 | | PEP 30-300 | | PEP 30-350 | | PEP 30-400 | |
|----------------------|-------------------|-------------------|-------------------|-------------------|-------------------|-------------------|-------------------|-------------------|-------------------|-------------------|
| | L = 0.96 – 1.50 m | | L = 1.46 – 2.50 m | | L = 1.71 – 3.00 m | | L = 1.96 – 3.50 m | | L = 2.21 – 4.00 m | |
| | Outer tube bottom | Inner tube bottom | Outer tube bottom | Inner tube bottom | Outer tube bottom | Inner tube bottom | Outer tube bottom | Inner tube bottom | Outer tube bottom | Inner tube bottom |
| 1.00 | 36.4 | 36.4 | | | | | | | | |
| 1.10 | 36.4 | 36.4 | | | | | | | | |
| 1.20 | 36.4 | 36.4 | | | | | | | | |
| 1.30 | 35.9 | 36.4 | | | | | | | | |
| 1.40 | 35.3 | 36.4 | | | | | | | | |
| 1.50 | 34.5 | 36.4 | 42.9 | 42.9 | | | | | | |
| 1.60 | | | 42.9 | 42.9 | | | | | | |
| 1.70 | | | 42.9 | 42.9 | | | | | | |
| 1.80 | | | 42.1 | 42.9 | 42.9 | 42.9 | | | | |
| 1.90 | | | 39.7 | 42.9 | 42.9 | 42.9 | | | | |
| 2.00 | | | 37.9 | 42.9 | 42.9 | 42.9 | 45.5 | 45.5 | | |
| 2.10 | | | 36.4 | 42.9 | 42.9 | 42.9 | 45.5 | 45.5 | | |
| 2.20 | | | 35.5 | 42.9 | 42.9 | 42.9 | 45.5 | 45.5 | | |
| 2.30 | | | 34.3 | 41.5 | 42.9 | 42.9 | 45.5 | 45.5 | 41.5 | 41.5 |
| 2.40 | | | 33.1 | 38.7 | 42.7 | 42.9 | 45.5 | 45.5 | 41.5 | 41.5 |
| 2.50 | | | 31.0 | 35.9 | 41.1 | 42.9 | 45.5 | 45.5 | 41.5 | 41.5 |
| 2.60 | | | | | 40.0 | 42.9 | 45.5 | 45.5 | 41.5 | 41.5 |
| 2.70 | | | | | 38.5 | 42.9 | 45.5 | 45.5 | 41.5 | 41.5 |
| 2.80 | | | | | 36.9 | 41.6 | 45.5 | 45.5 | 41.5 | 41.5 |
| 2.90 | | | | | 34.2 | 38.3 | 45.0 | 45.5 | 41.5 | 41.5 |
| 3.00 | | | | | 31.3 | 34.8 | 43.6 | 45.5 | 41.5 | 41.5 |
| 3.10 | | | | | | | 41.4 | 44.2 | 41.5 | 41.5 |
| 3.20 | | | | | | | 38.7 | 42.1 | 41.5 | 41.5 |
| 3.30 | | | | | | | 36.1 | 38.7 | 41.5 | 41.5 |
| 3.40 | | | | | | | 33.3 | 35.7 | 41.5 | 41.5 |
| 3.50 | | | | | | | 30.7 | 32.5 | 41.5 | 41.5 |
| 3.60 | | | | | | | | | 41.5 | 41.5 |
| 3.70 | | | | | | | | | 41.3 | 41.5 |
| 3.80 | | | | | | | | | 38.5 | 41.3 |
| 3.90 | | | | | | | | | 35.9 | 38.1 |
| 4.00 | | | | | | | | | 33.2 | 34.7 |

All PEP 30 Props correspond to Class E of DIN EN 1065, i. e. the permissible prop load for all extension lengths is a minimum of 30 kN.

Permissible prop load [kN]

| Extension length [m] | PEP Ergo B-300 | | PEP Ergo B-350 | |
|----------------------|-------------------|-------------------|-------------------|-------------------|
| | L = 1.97 – 3.00 m | | L = 2.25 – 3.50 m | |
| | Outer tube bottom | Inner tube bottom | Outer tube bottom | Inner tube bottom |
| 2.00 | 30.8 | 30.8 | | |
| 2.10 | 29.8 | 30.8 | | |
| 2.20 | 27.0 | 30.8 | | |
| 2.30 | 24.6 | 30.8 | 30.8 | 28.6 |
| 2.40 | 23.0 | 30.8 | 28.6 | 28.6 |
| 2.50 | 21.5 | 30.8 | 25.5 | 28.6 |
| 2.60 | 20.3 | 29.5 | 23.1 | 28.4 |
| 2.70 | 19.3 | 27.5 | 21.3 | 28.0 |
| 2.80 | 18.3 | 24.4 | 19.8 | 27.4 |
| 2.90 | 16.9 | 22.3 | 18.6 | 26.1 |
| 3.00 | 15.6 | 19.9 | 17.5 | 24.4 |
| 3.10 | | | 16.3 | 22.8 |
| 3.20 | | | 15.2 | 20.8 |
| 3.30 | | | 14.3 | 19.0 |
| 3.40 | | | 13.2 | 17.4 |
| 3.50 | | | 12.4 | 15.7 |

Note:

- PERI PEP Ergo B-300 and PEP Ergo B-350 Props meet the load-bearing capacity requirements of Prop Class B as stipulated in DIN EN 1065.
- General Building Inspectorate Approval Z-8.311-934 issued by the German Institute for Building Technology.

Permissible prop load [kN]

| Extension length [m] | PEP Ergo D-150 | | PEP Ergo D-250 | | PEP Ergo D-300 + | |
|----------------------|-------------------|-------------------|-------------------|-------------------|-------------------|-------------------|
| | L = 0.98 – 1.50 m | | L = 1.47 – 2.50 m | | L = 1.79 – 3.00 m | |
| | Outer tube bottom | Inner tube bottom | Outer tube bottom | Inner tube bottom | Outer tube bottom | Inner tube bottom |
| 1.00 | 30.8 | 30.8 | | | | |
| 1.10 | 30.8 | 30.8 | | | | |
| 1.20 | 30.8 | 30.8 | | | | |
| 1.30 | 30.8 | 30.8 | | | | |
| 1.40 | 28.5 | 30.8 | | | | |
| 1.50 | 26.4 | 30.8 | 35.0 | 35.0 | | |
| 1.60 | | | 35.0 | 35.0 | | |
| 1.70 | | | 32.9 | 35.0 | | |
| 1.80 | | | 30.7 | 35.0 | 35.0 | 35.0 |
| 1.90 | | | 29.1 | 35.0 | 35.0 | 35.0 |
| 2.00 | | | 28.1 | 35.0 | 35.0 | 35.0 |
| 2.10 | | | 27.3 | 35.0 | 35.0 | 35.0 |
| 2.20 | | | 26.5 | 34.1 | 35.0 | 35.0 |
| 2.30 | | | 25.7 | 31.7 | 33.4 | 35.0 |
| 2.40 | | | 24.3 | 28.5 | 31.7 | 34.0 |
| 2.50 | | | 22.4 | 26.3 | 30.1 | 32.7 |
| 2.60 | | | | | 28.3 | 31.3 |
| 2.70 | | | | | 26.2 | 29.1 |
| 2.80 | | | | | 24.3 | 26.9 |
| 2.90 | | | | | 22.4 | 24.9 |
| 3.00 | | | | | 20.6 | 22.8 |

Note:

- PERI PEP Ergo D-150, PEP Ergo D-250, PEP Ergo D-300 + Props fulfil Prop Class D load-bearing capacity requirements of DIN EN 1065.
- In addition, Prop PEP Ergo D-250 fulfils the Prop Class B requirements as stipulated in DIN EN 1065.
- General Building Inspectorate Approval Z-8.311-934 for PERI PEP Ergo D-150, PEP Ergo D-250 and PEP Ergo D-300 +.

Load charts for slab props

PEP Ergo D

Permissible prop load [kN]

| Extension length [m] | PEP Ergo D-350 + | | PEP Ergo D-400 | | PEP Ergo D-500 | |
|----------------------|-------------------|-------------------|-------------------|-------------------|-------------------|-------------------|
| | L = 2.08 – 3.50 m | | L = 2.51 – 4.00 m | | L = 3.26 – 5.00 m | |
| | Outer tube bottom | Inner tube bottom | Outer tube bottom | Inner tube bottom | Outer tube bottom | Inner tube bottom |
| 2.10 | 40.0 | 40.0 | | | | |
| 2.20 | 40.0 | 40.0 | | | | |
| 2.30 | 40.0 | 40.0 | | | | |
| 2.40 | 39.7 | 40.0 | | | | |
| 2.50 | 36.9 | 40.0 | | | | |
| 2.60 | 34.7 | 40.0 | | | | |
| 2.70 | 32.9 | 40.0 | 40.0 | 40.0 | | |
| 2.80 | 31.6 | 40.0 | 40.0 | 40.0 | | |
| 2.90 | 30.3 | 40.0 | 40.0 | 40.0 | | |
| 3.00 | 29.2 | 39.1 | 40.0 | 40.0 | | |
| 3.10 | 27.2 | 35.4 | 37.7 | 40.0 | | |
| 3.20 | 25.4 | 32.1 | 35.7 | 40.0 | | |
| 3.30 | 23.7 | 29.4 | 33.9 | 40.0 | 40.0 | 40.0 |
| 3.40 | 22.1 | 27.0 | 32.5 | 40.0 | 40.0 | 40.0 |
| 3.50 | 20.7 | 24.4 | 31.0 | 39.7 | 40.0 | 40.0 |
| 3.60 | | | 29.0 | 36.4 | 40.0 | 40.0 |
| 3.70 | | | 27.0 | 33.3 | 40.0 | 40.0 |
| 3.80 | | | 25.2 | 30.7 | 40.0 | 40.0 |
| 3.90 | | | 23.5 | 28.2 | 40.0 | 40.0 |
| 4.00 | | | 21.8 | 26.0 | 40.0 | 40.0 |
| 4.10 | | | | | 39.3 | 40.0 |
| 4.20 | | | | | 36.5 | 40.0 |
| 4.30 | | | | | 34.0 | 39.2 |
| 4.40 | | | | | 31.8 | 37.0 |
| 4.50 | | | | | 29.9 | 34.6 |
| 4.60 | | | | | 28.1 | 32.4 |
| 4.70 | | | | | 26.4 | 30.4 |
| 4.80 | | | | | 24.8 | 28.5 |
| 4.90 | | | | | 23.4 | 26.8 |
| 5.00 | | | | | 21.8 | 25.3 |

Note:

- PERI PEP Ergo D-350 +, PEP Ergo D-400 and PEP Ergo D-500 Props fulfil Prop Class D load-bearing capacity requirements of DIN EN 1065.
- General Building Inspectorate Approval Z-8.311-941 for PERI PEP Ergo D-350 +, PEP Ergo D-400 and PEP Ergo D-500.

Load charts for slab props

PEP Ergo E



Permissible prop load [kN]

| Extension length [m] | PEP Ergo E-300 + | | PEP Ergo E-350 + | | PEP Ergo E-400 | |
|----------------------|-------------------|-------------------|-------------------|-------------------|-------------------|-------------------|
| | L = 1.79 – 3.00 m | | L = 2.08 – 3.50 m | | L = 2.51 – 4.00 m | |
| | Outer tube bottom | Inner tube bottom | Outer tube bottom | Inner tube bottom | Outer tube bottom | Inner tube bottom |
| 1.80 | 50.4 | 50.4 | | | | |
| 1.90 | 50.4 | 50.4 | | | | |
| 2.00 | 50.4 | 50.4 | | | | |
| 2.10 | 50.4 | 50.4 | 50.4 | 50.4 | | |
| 2.20 | 50.4 | 50.4 | 50.4 | 50.4 | | |
| 2.30 | 50.4 | 50.4 | 50.4 | 50.4 | | |
| 2.40 | 47.3 | 50.4 | 50.4 | 50.4 | | |
| 2.50 | 45.6 | 50.4 | 50.4 | 50.4 | | |
| 2.60 | 44.5 | 50.4 | 50.4 | 50.4 | 50.4 | 50.4 |
| 2.70 | 43.3 | 50.4 | 48.5 | 50.4 | 50.4 | 50.4 |
| 2.80 | 41.8 | 50.4 | 46.4 | 50.4 | 50.4 | 50.4 |
| 2.90 | 40.3 | 48.0 | 44.5 | 50.4 | 50.4 | 50.4 |
| 3.00 | 37.5 | 43.0 | 43.0 | 50.4 | 50.4 | 50.4 |
| 3.10 | | | 41.5 | 50.4 | 50.4 | 50.4 |
| 3.20 | | | 38.7 | 46.1 | 50.4 | 50.4 |
| 3.30 | | | 36.0 | 41.9 | 50.4 | 50.4 |
| 3.40 | | | 33.3 | 38.2 | 50.4 | 50.4 |
| 3.50 | | | 30.9 | 34.7 | 48.5 | 50.4 |
| 3.60 | | | | | 46.0 | 50.4 |
| 3.70 | | | | | 42.7 | 48.4 |
| 3.80 | | | | | 39.7 | 44.7 |
| 3.90 | | | | | 36.9 | 41.1 |
| 4.00 | | | | | 34.1 | 37.7 |

Note:

- PERI Props PEP Ergo E-300 +, PEP Ergo E-350 + and PEP Ergo E-400 fulfil the Prop Class E load-bearing capacity requirements of DIN EN 1065.
- General Building Inspectorate Approval Z-8.311-941 of the German Institute for Building Technology.

Load charts for slab props

PEP Alpha, PEP Alpha-2

Permissible prop load [kN]

| Extension length [m] | PEP Alpha | | PEP Alpha-2 | | | |
|----------------------|---------------------------------|---------------------------------|-------------------|-------------------|-------------------|-------------------|
| | B-300 | B-350 | B-300 | | B-350 | |
| | Outer tube or inner tube bottom | Outer tube or inner tube bottom | Outer tube bottom | Inner tube bottom | Outer tube bottom | Inner tube bottom |
| 1.70 | | | | | | |
| 1.80 | 30.0 | | 32.4 | 32.4 | | |
| 1.90 | 30.0 | | 31.7 | 32.4 | | |
| 2.00 | 30.0 | | 30.4 | 32.4 | 34.9 | 34.9 |
| 2.10 | 27.2 | 30.0 | 27.9 | 32.4 | 33.2 | 34.9 |
| 2.20 | 24.9 | 28.9 | 25.5 | 32.4 | 30.1 | 34.9 |
| 2.30 | 22.6 | 26.4 | 23.4 | 32.4 | 27.3 | 34.9 |
| 2.40 | 20.8 | 24.3 | 22.6 | 32.4 | 25.0 | 34.9 |
| 2.50 | 19.2 | 22.4 | 21.7 | 30.5 | 23.3 | 34.9 |
| 2.60 | 17.7 | 20.7 | 20.4 | 27.2 | 22.1 | 34.7 |
| 2.70 | 16.4 | 19.2 | 19.0 | 24.6 | 21.1 | 31.5 |
| 2.80 | 15.3 | 17.8 | 17.8 | 22.4 | 19.7 | 28.1 |
| 2.90 | 14.2 | 16.6 | 16.7 | 20.7 | 18.5 | 25.3 |
| 3.00 | 13.3 | 15.5 | 15.5 | 18.9 | 17.4 | 23.1 |
| 3.10 | | 14.5 | | | 16.5 | 21.3 |
| 3.20 | | 13.6 | | | 15.5 | 19.6 |
| 3.30 | | 12.8 | | | 14.6 | 17.7 |
| 3.40 | | 12.1 | | | 13.3 | 15.8 |
| 3.50 | | 11.4 | | | 12.1 | 14.3 |

| Extension length [m] | PEP Alpha | | | | PEP Alpha-2 | | | |
|----------------------|-------------------|-------------------|-------------------|-------------------|-------------------|-------------------|-------------------|-------------------|
| | D-300 | | D-350 | | D-300 | | D-350 | |
| | Outer tube bottom | Inner tube bottom | Outer tube bottom | Inner tube bottom | Outer tube bottom | Inner tube bottom | Outer tube bottom | Inner tube bottom |
| 1.70 | 36.1 | 36.1 | | | | | | |
| 1.80 | 36.1 | 36.1 | | | 36.1 | 36.1 | | |
| 1.90 | 36.1 | 36.1 | | | 36.1 | 36.1 | | |
| 2.00 | 36.1 | 36.1 | 36.1 | 36.1 | 36.1 | 36.1 | 36.1 | 36.1 |
| 2.10 | 35.6 | 36.1 | 36.1 | 36.1 | 36.0 | 36.1 | 36.1 | 36.1 |
| 2.20 | 33.8 | 36.1 | 36.1 | 36.1 | 33.8 | 36.1 | 36.1 | 36.1 |
| 2.30 | 32.1 | 36.1 | 36.1 | 36.1 | 32.1 | 36.1 | 36.1 | 36.1 |
| 2.40 | 30.9 | 36.1 | 36.1 | 36.1 | 30.9 | 36.1 | 36.1 | 36.1 |
| 2.50 | 29.7 | 35.2 | 36.1 | 36.1 | 29.7 | 36.1 | 36.1 | 36.1 |
| 2.60 | 27.5 | 33.2 | 35.6 | 36.1 | 27.5 | 34.3 | 35.7 | 36.1 |
| 2.70 | 25.5 | 30.6 | 33.9 | 36.1 | 25.5 | 30.9 | 34.3 | 36.1 |
| 2.80 | 23.6 | 28.1 | 32.7 | 36.1 | 23.6 | 28.1 | 32.9 | 36.1 |
| 2.90 | 21.9 | 25.8 | 31.2 | 36.1 | 21.9 | 25.8 | 31.8 | 36.1 |
| 3.00 | 20.6 | 23.5 | 29.1 | 36.1 | 20.6 | 23.5 | 29.8 | 36.1 |
| 3.10 | | | 27.3 | 34.2 | | | 27.9 | 34.3 |
| 3.20 | | | 25.5 | 31.4 | | | 26.1 | 31.7 |
| 3.30 | | | 23.7 | 28.7 | | | 24.4 | 28.8 |
| 3.40 | | | 22.1 | 26.3 | | | 22.7 | 26.5 |
| 3.50 | | | 20.6 | 24.2 | | | 21.1 | 24.3 |

Note:

- The props fulfil the load-bearing capacity requirements of DIN EN 1065.

| Item no. | Weight kg |
|----------|-----------|
|----------|-----------|

| | | |
|--------|-------|--|
| 135243 | 49.00 | Panel ADP Panel ADP 240 x 120 |
| 135178 | 38.10 | Panel ADP Panel ADP 180 x 120 |

powder coated aluminium frame with 9 mm thick birch ply as formlining.

| L | B |
|------|------|
| 2400 | 1200 |
| 1800 | 1200 |

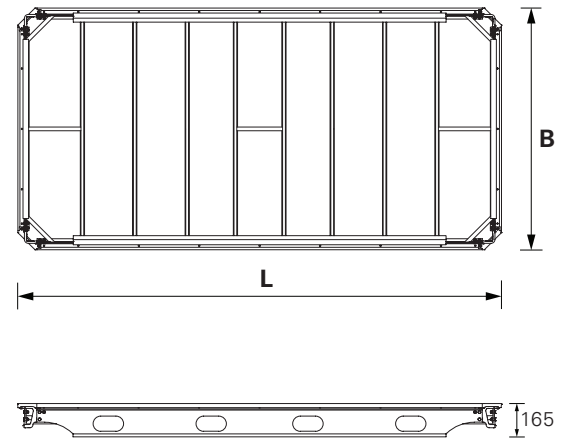
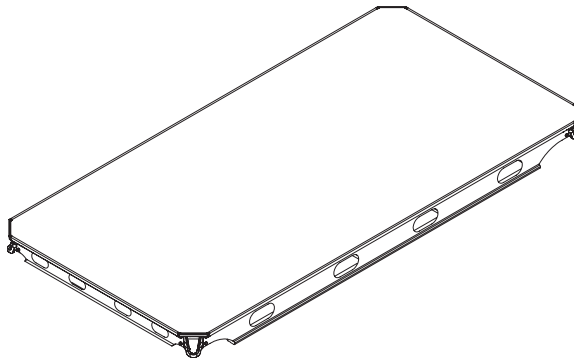

| | | |
|--------|------|--|
| 134689 | 6.95 | Drophead ADH Lowering height 12 cm. Only one type of head serves all requirements. |
|--------|------|--|

Complete with
 4 pc. 102120 Bolt M12 x 30, grade 8.8 (ISO 4017)
 4 pc. 710381 Nut M12, grade 8 (ISO 7042)
 4 pc. 780702 Washer M12, 200HV (ISO 7089)

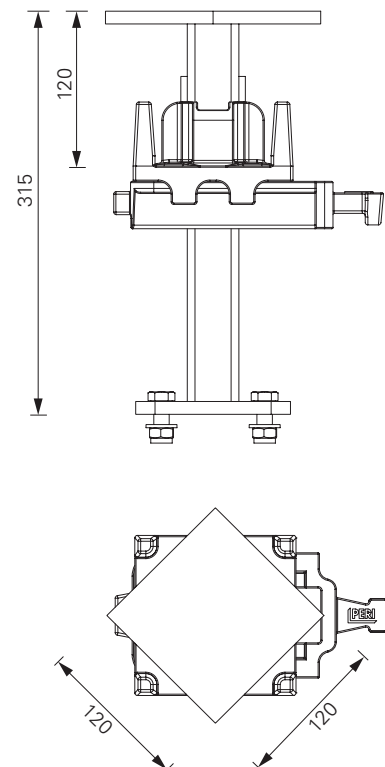
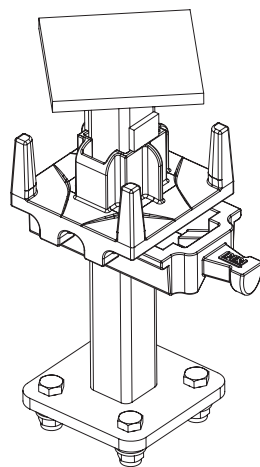

Item no. Weight kg

| | | |
|--------|-------|--|
| 135675 | 13.30 | Filler Beam ADF |
| 135671 | 10.40 | Filler Beam ADF 240 Filler Beam ADF 180 |

For filler areas.
'Timber insert' not included.

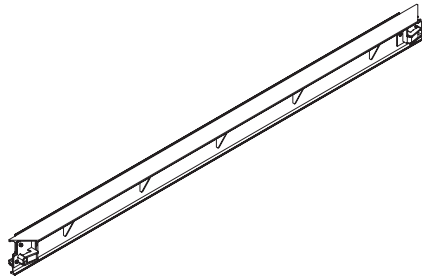

| L |
|------|
| 2400 |
| 1800 |

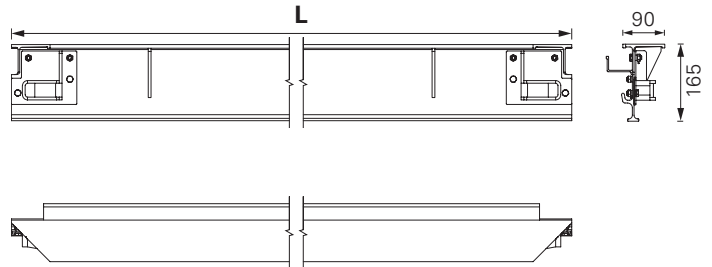

| | | |
|--------|------|----------------------------|
| 135667 | 6.60 | Filler Beam ADF 120 |
|--------|------|----------------------------|

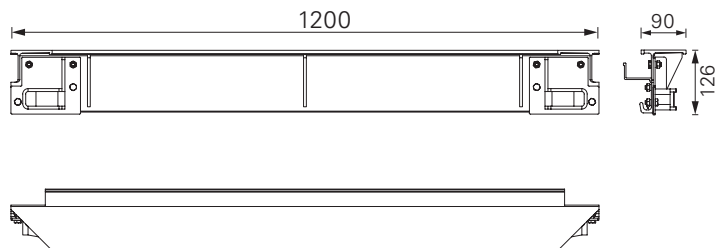
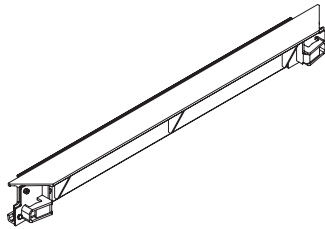

| | | |
|--------|-------|--|
| 135246 | 31.30 | Brace ADB |
| 135245 | 25.50 | Brace ADB 240 |
| 135244 | 19.70 | Brace ADB 180 Brace ADB 120 |

For stability during erection.

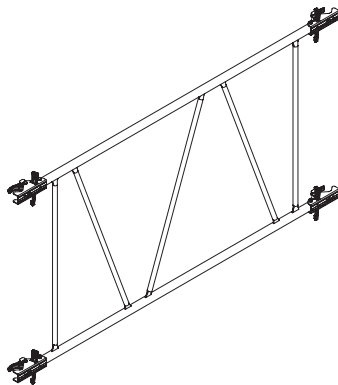

| L | B |
|------|------|
| 2400 | 1200 |
| 1800 | 1200 |
| 1200 | 1200 |

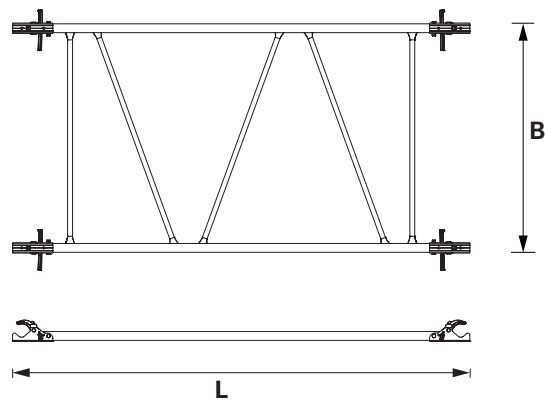

| | | |
|--------|------|--------------------------|
| 135615 | 4.20 | Shuttering Aid AD |
|--------|------|--------------------------|

For comfortable and safe shuttering.

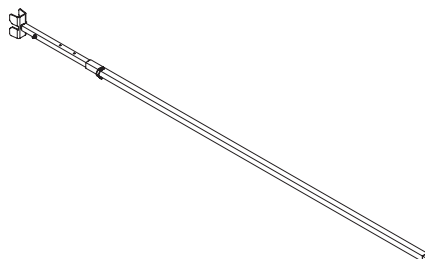

Complete with

- 1 pc. 780814 Linch Pin
- 1 pc. 710335 Bolt M10 x 50
- 1 pc. 710234 Nut M10

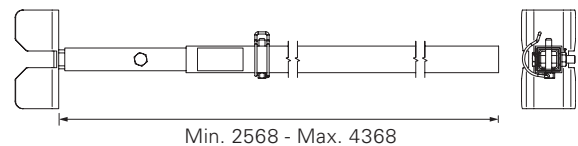

| Item no. | Weight kg | |
|----------|-----------|--|
|----------|-----------|--|

| | | |
|--------|------|--|
| 135605 | 4.71 | <p>Guardrail Post Holder ADG Guardrail for safe working after shuttering. Use in combination with Guardrail Post HSGP-2</p> |
|--------|------|--|

Complete with

- 1 pc. 018050 Pin Ø 16 x 65/86, galv.
- 1 pc. 018060 Cotter Pin 4/1, galv.

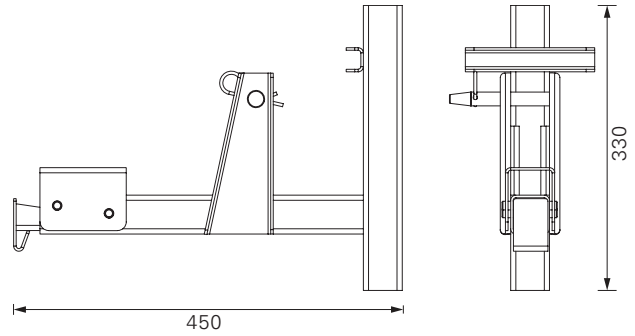
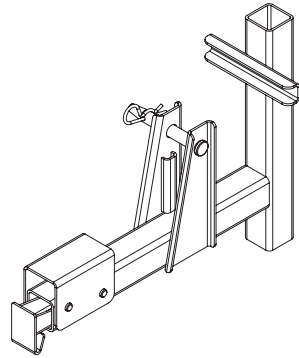

| | | |
|--------|------|-------------------------------------|
| 116292 | 4.72 | <p>Guardrail Post HSGP-2</p> |
|--------|------|-------------------------------------|

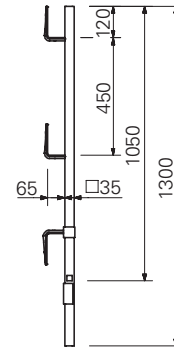

| | | |
|--------|-------|--|
| 065016 | 88.20 | <p>Crate Pallet 80 x 120-K, painted For stacking and transportation of formwork components.</p> |
|--------|-------|--|

Note

Follow Instructions for Use!

Technical Data

Permissible load-bearing capacity 1.5 t.
Capacity approx. 0.75 m³.

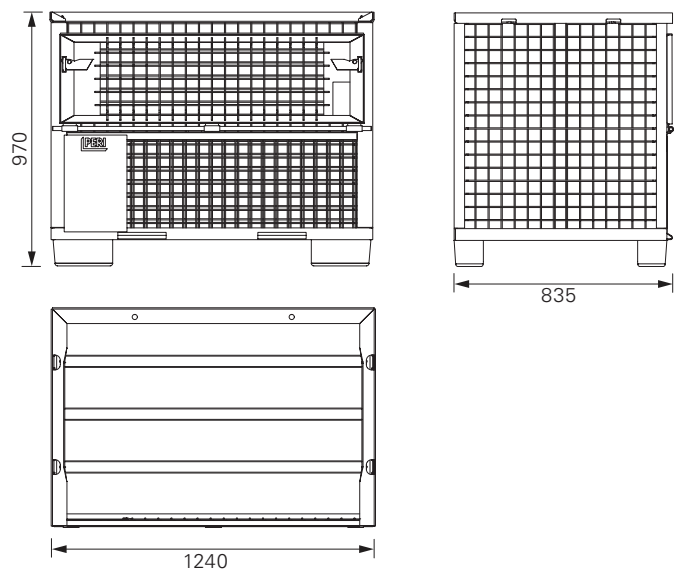
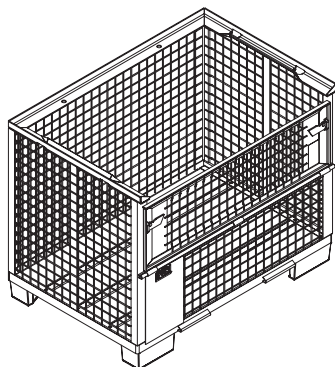

| Item no. | Weight kg |
|----------|-----------|
|----------|-----------|

| | |
|--------|-------|
| 135713 | 79.40 |
| 135719 | 71.50 |

Pallet AD

Pallet AD 240

Pallet AD 180

For stacking and transportation of Panels ADP

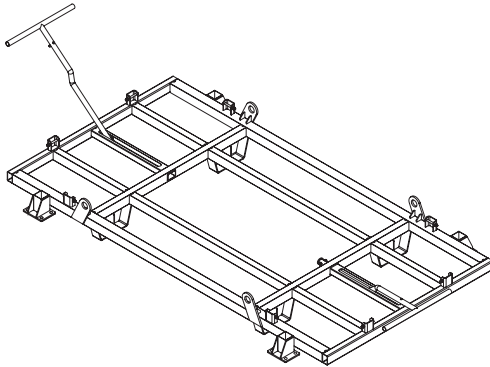

Complete with

4 pc. 710594 Belt Spanner Unit L = 1400 mm

2 pc. 710595 Belt Lose End L = 4200 mm

2 pc. 710596 Belt Lose End L = 5000 mm

Note

Follow Instructions for Use!

Technical Data

Permissible load-bearing capacity 600 kg.

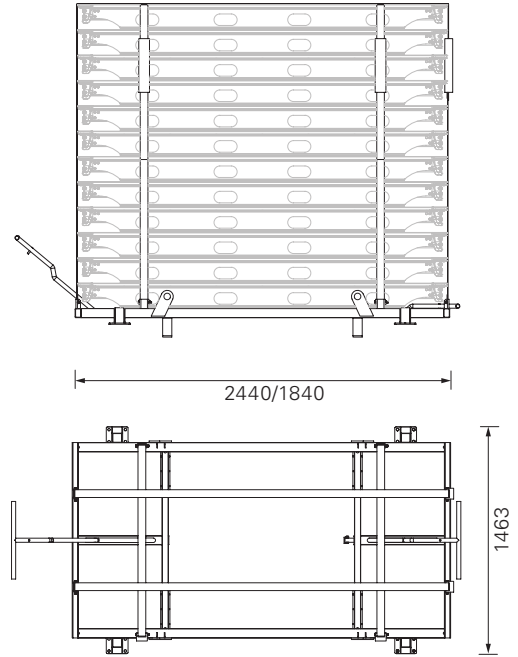

| | |
|--------|------|
| 111690 | 4.14 |
|--------|------|

Swivel Castor Wheel with Brake

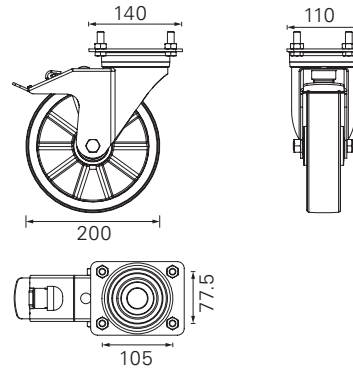
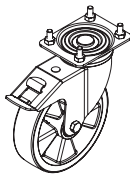

| | |
|--------|------|
| 116436 | 0.03 |
| 710234 | 0.01 |

Accessories

Bolt M10 x 30, galv.

Nut M10, galv.

| | |
|--------|------|
| 135685 | 1.74 |
|--------|------|

Cross Beam Head

For infill areas.

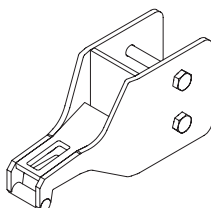

Complete with

2 pc. 710593 Bolt M10 x 80

2 pc. 710234 Nut M10

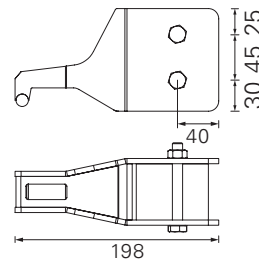

| Item no. | Weight kg | |
|----------|-----------|----------------------|
| 135653 | 3.29 | Crosshead ADC |

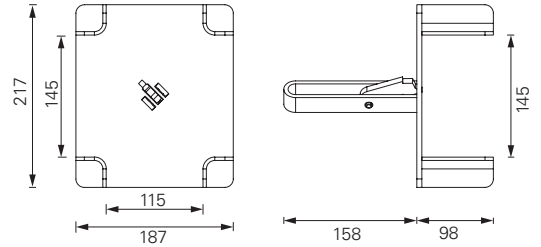
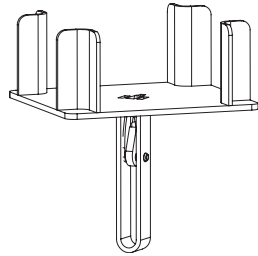

| | | | |
|--------|------|--|--|
| 124777 | 0.21 | Anchor Bolt PERI 14/20 x 130 For temporary fixation to reinforced concrete structures. | Note See PERI data sheet! Drilling \varnothing 14 mm. |
|--------|------|--|--|

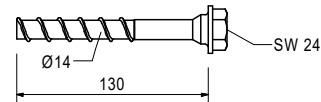
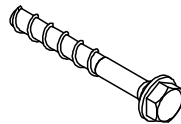

| | | | |
|--------|------|---------------------------------------|--|
| 065073 | 1.37 | Anchor Chain 3.0 kN, l = 2.5 m | Technical Data Permissible tension force 3.0 kN. |
|--------|------|---------------------------------------|--|

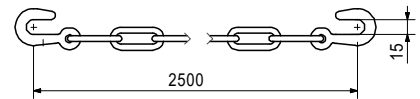
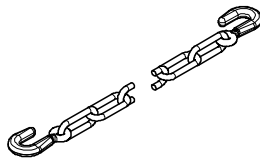

| | | | |
|--------|------|-------------------------------|--|
| 065074 | 0.45 | Turnbuckle 3.0 kN, M12 | Technical Data Permissible tension force 3.0 kN. |
|--------|------|-------------------------------|--|

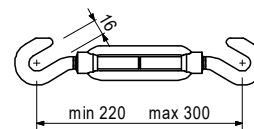
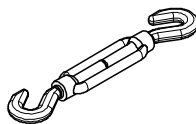

| | | | |
|--------|------|---|--|
| 028100 | 1.83 | Base Plate for RS For securing anchor chains. | Complete with 1 pc. 018050 Pin \varnothing 16 x 65/86, galv. 1 pc. 018060 Cotter Pin 4/1, galv. |
|--------|------|---|--|

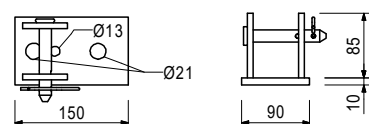
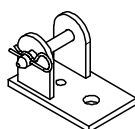

**The optimal
System for every
Project and every
Requirement**



Wall Formwork



Column Formwork



Slab Formwork



Climbing System



Bridge Formwork



Tunnel Formwork



Shoring Systems



Construction Scaffold



Facade Scaffold



Industrial Scaffold



Access



Protection Scaffold



Safety Systems



**System-Independent
Accessories**



Services



PERI GmbH
Formwork Scaffolding Engineering
 Rudolf-Diesel-Strasse 19
 89264 Weissenhorn
 Germany
 Tel. +49 (0)7309.950-0
 Fax +49 (0)7309.951-0
 info@peri.com
 www.peri.com

